

## Take control

The ecoFIT sustain boilers are compatible with Vaillant's complete range of intelligent controls. From the simplicity of our analogue heating controls to wireless thermostats, you're sure to find a control that's a smart choice for every installation.

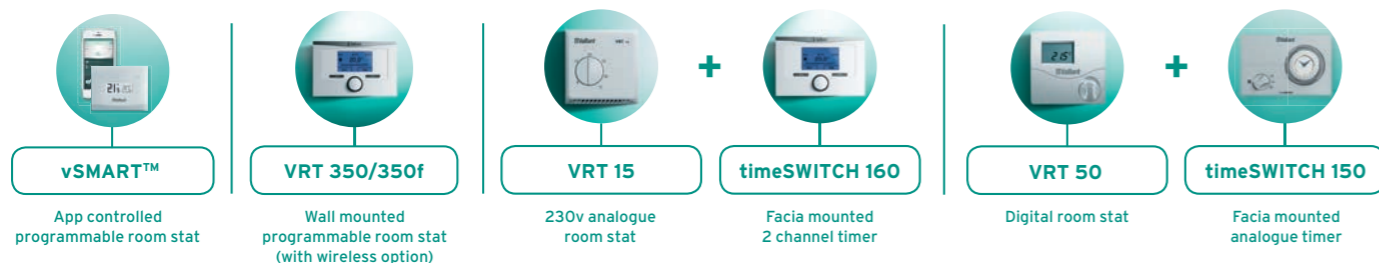

When a vSMART™ app control is added, the ecoFIT sustain will achieve an A+ ErP rating, making it welcome in any switched-on, energy-conscious home. It's convenient, energy efficient, and saves on energy bills.

For more information on Vaillant's range of intelligent controls, please visit [www.vaillant.co.uk/specifiers](http://www.vaillant.co.uk/specifiers)

## Contacts

### North

#### Northern Specification Director

Manuel Puletti  
**07768 532145**  
[manuel.puletti@vaillant.com](mailto:manuel.puletti@vaillant.com)

#### Key Account Managers:

**Neil Noades**  
**07802 673755**  
[neil.noades@vaillant.com](mailto:neil.noades@vaillant.com)  
Postcode areas covered:  
**CA, DH, DL, HG, LA, NE, SR, TS, YO**

**Jonathan Nisbet**  
**07736 742402**  
[jonathan.nisbet@vaillant.com](mailto:jonathan.nisbet@vaillant.com)  
Postcode areas covered:  
**BD, DN, HD, HU, HX, LS, S, WF**

**Jack Buckley**  
**07802 673750**  
[jack.buckley@vaillant.com](mailto:jack.buckley@vaillant.com)  
Postcode areas covered:  
**BB, BL, CH, CW, FY, IM, L, LL, M, OL, PR, SK, WA, WN**

**Greg Wilson**  
**07951 204824**  
[greg.wilson@vaillant.com](mailto:greg.wilson@vaillant.com)  
Postcode areas covered:  
**B, CV, DE, DY, LE, NG, NN, ST, SY, TF, WR, WS, WV**

### South

#### Southern Specification Director

Alastair Thorpe  
**07798 504686**  
[alastair.thorpe@vaillant.com](mailto:alastair.thorpe@vaillant.com)

#### Key Account Managers:

**Matthew Beales**  
**07802 673752**  
[matthew.beales@vaillant.com](mailto:matthew.beales@vaillant.com)  
Postcode areas covered:  
**CB, CM, CO, IP, LN, NR, PE, SS**

**Lee Bland**  
**07802 673753**  
[lee.bland@vaillant.com](mailto:lee.bland@vaillant.com)  
Postcode areas covered:  
**AL, E, EC, EN, HA, IG, LU, MK, N, NW, RM, SG, UB, W, WC, WD**

**Garry Scott-Parker**  
**07984 551446**  
[garry.scott-parker@vaillant.com](mailto:garry.scott-parker@vaillant.com)  
Postcode areas covered:  
**BH, GU, HP, KT, OX, PO, RG, SL, SO, SP, TW**

**Ken Gilbey**  
**07977 994249**  
[ken.gilbey@vaillant.com](mailto:ken.gilbey@vaillant.com)  
Postcode areas covered:  
**BN, BR, CR, CT, DA, ME, RH, SE, SM, SW, TN**

**Rhys Morgan**  
**07802 673754**  
[rhys.morgan@vaillant.com](mailto:rhys.morgan@vaillant.com)  
Postcode areas covered:  
**BA, BS, CF, DT, EX, GL, HR, LD, NP, PL, SA, SN, TA, TQ, TR**

### Scotland

#### Sales Director

Matt Clarke  
**07767 377531**  
[matt.clarke@vaillant.com](mailto:matt.clarke@vaillant.com)

#### Regional Sales Manager:

**Matt Murray**  
**07802 673743**  
[matthew.murray@vaillant.com](mailto:matthew.murray@vaillant.com)

#### Key Account Manager:

**Peter Kelly**  
**07802 673739**  
[peter.kelly@vaillant.com](mailto:peter.kelly@vaillant.com)  
Postcode areas covered:  
**AB, DD, DG, EH, FK, G, HS, IV, KA, KW, KY, ML, PA, PH, TD**

### National Accounts

#### National Account Manager North

Paul Jones  
**07534 910207**  
[paul.jones@vaillant.com](mailto:paul.jones@vaillant.com)

#### National Account Manager South

Sam Marsden  
**07802 673745**  
[samuel.marsden@vaillant.com](mailto:samuel.marsden@vaillant.com)



**Why Vaillant?**

Because social housing is where we're right at home.

■ ecoFIT sustain



As one of Europe's leading heating technology manufacturers, 'thinking ahead' is a culture which is embraced throughout Vaillant. Our products feature high energy efficiency ratings and low emissions, and come

with an enviable reputation for performance, quality and reliability. This comes from proven German engineering combined with award-winning UK manufacturing.

## The new ecoFIT sustain.

A perfect fit for social housing.

Ultra-quiet operation (Quiet Mark-approved), the ecoFIT sustain has a small footprint coupled with rear and top flue options offering total flexibility of siting, making it the perfect solution for tenant properties.

The ecoFIT sustain range of combi boilers offers an excellent size-to-output ratio, giving your tenants great comfort whilst ensuring a small footprint. Use of sustainable materials also means the boiler is 100% recyclable. The range features 25, 30 and 35kW models to suit all types of tenant properties. Where a specification requires a system or open vent boiler, ecoFIT pure products can be used.



Vaillant is working in partnership with National Energy Action to reduce fuel poverty.

Visit [www.vaillant.co.uk/specifiers](http://www.vaillant.co.uk/specifiers) to find out more.

## Key features and benefits

- **Cupboard fit**  
Compact size (702mm x 390mm x 295mm) offers flexibility of siting including the option to cupboard fit
- **Choice of rear or top flue**  
For even more flexible siting options in a wide variety of properties
- **High SAP performance**  
Helps reduce new build cost by up to 4% on TER. Highly efficient and economical to run - up to an 89.3% efficiency rating (SAP 2009)
- **High-quality lightweight aluminium heat exchanger**  
Lightweight, compact design offers long life with an excellent power-to-weight ratio makes installs/maintenance easier
- **Heat exchanger includes patented 4-sided cooling**  
Increases efficiency and reduces stress to minimise the cost of maintenance over the life of the product
- **Familiar Vaillant diagnostics**  
Offers quick and easy maintenance for your maintenance team
- **Patented condensate trap**  
Easy install with a safety back-up
- **Fully modulating low NOx burner and fan**  
For improved energy efficiency
- **Recognised Grundfos high-efficiency pump**  
Modulating high-torque pump uses low energy to deliver a balanced output to meet the boiler demand, helping to reduce energy consumption
- **Built-in two-stage frost protection**  
To ensure optimal performance all year round
- **Warm start function**  
Provides tenants with instant hot water
- **Modulation range of up to 1:4**  
Ensuring low energy consumption and maximum efficiency
- **Clear bright LCD display**  
Easy-to-read boiler display wherever it is sited
- **Best-in-class flue length (up to 10m)**  
Allows maximum flexibility for location of the boiler
- **Controls compatibility**  
The wide range of Vaillant room thermostats, wired and wireless controls including the vSMART™ app-based control with weather compensation to lower running costs for tenants
- **Quiet Mark accredited**  
Thanks to being ultra-quiet whilst in operation
- **ErP A rated product**  
Suitable for both refurbishment and new build with lower running cost to reduce tenants' bills

## ecoFIT sustain combination boiler 25, 30, 35

Clearances:

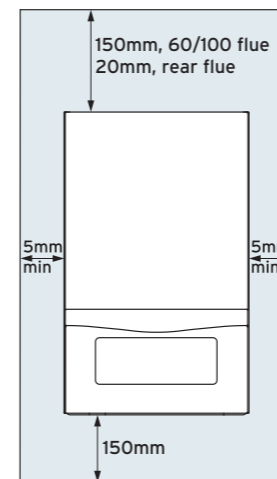

Dimensions:

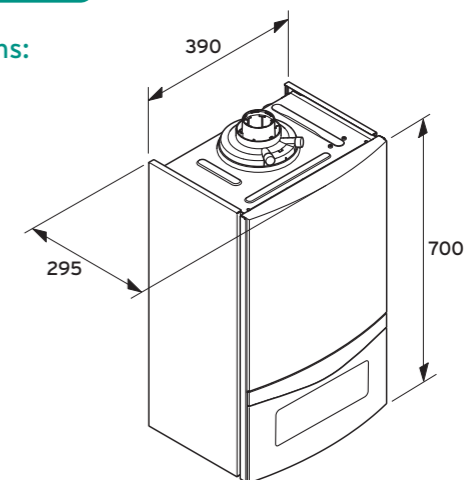

Note: A 600mm front clearance is recommended to allow easy access during inspection and maintenance

Technical data	25kW combi	30kW combi	35kW combi
Article number	0010020392	0010020393	0010020394
Boiler dimensions (HxWxD) (mm)	702 x 390 x 295	702 x 390 x 295	702 x 390 x 295
Rear and top flue options	Yes	Yes	Yes
Boiler lift weight (kg)	32	33	33
Nominal heat output range at 50/30°C (kW)	5.3 - 19.1	6.3 - 19.1	7.5 - 19.1
Nominal heat output range at 80/60°C (kW)	5.1 - 18.3	6.1 - 18.3	7.2 - 18.3
Maximum flow temperature (°C)	80	80	80
Flow temperature range (°C)	10 - 80	10 - 80	10 - 80
Domestic hot water flow rate l/hr (at DT = 35K)	10.4	12.4	14.4
Flow temperature factory setting (°C)	75	75	75
Approximate condensate volume at 50/30°C (l/hr)	1.84	1.84	1.84
Maximum horizontal flue length 60/100 (m)	10	10	10
PCDB seasonal efficiency (%)	89.3	89.3	89.3
ErP rating (heating/hot water)	A/A	A/A	A/A

Vaillant Group UK Ltd.

Nottingham Road ■ Belper ■ Derbyshire DE56 1JT ■ Telephone 0345 602 2922 ■ [www.vaillant.co.uk/specifiers](http://www.vaillant.co.uk/specifiers) ■ [info@vaillant.co.uk](mailto:info@vaillant.co.uk)