

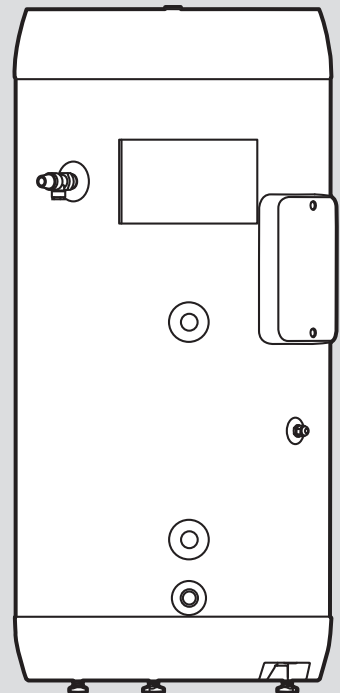

uniSTOR HP

VIH RW GB ... BES



Operating instructions

Contents

1	Safety	3
1.1	Intended use	3
1.2	General safety information.....	3
2	Notes on the documentation	5
2.1	Observing other applicable documents	5
2.2	Storing documents.....	5
2.3	Validity of the instructions	5
2.4	Benchmark.....	5
3	Product description	6
3.1	Serial number	6
3.2	Information on the data plate	6
3.3	CE marking	6
3.4	Hot Water Association	6
4	Function	6
4.1	Setting the domestic hot water temperature	6
4.2	Switching off the hot water generation.....	6
5	Troubleshooting	6
5.1	Detecting and eliminating faults.....	6
6	Care and maintenance	7
6.1	Maintenance	7
6.2	Caring for the product.....	7
7	Decommissioning	7
7.1	Temporarily decommissioning the product.....	7
7.2	Permanently decommissioning the product.....	7
8	Recycling and disposal	7
9	Guarantee and customer service	7
9.1	Guarantee.....	7
9.2	Customer service.....	8
	Appendix	9
A	Troubleshooting	9
	Index	10

1 Safety

1.1 Intended use

There is a risk of injury or death to the user or others, or of damage to the product and other property in the event of improper use or use for which it is not intended.

The product is intended as a system component for domestic hot water generation and storage for closed central heating installations.

Intended use includes the following:

- observance of the operating instructions included for the product and any other installation components
- compliance with all inspection and maintenance conditions listed in the instructions.

This product can be used by children aged from 8 years and above and persons with reduced physical, sensory or mental capabilities or lack of experience and knowledge if they have been given supervision or instruction concerning use of the product in a safe way and understand the hazards involved. Children must not play with the product. Cleaning and user maintenance work must

not be carried out by children unless they are supervised.

Any other use that is not specified in these instructions, or use beyond that specified in this document, shall be considered improper use. Any direct commercial or industrial use is also deemed to be improper.

Caution.

Improper use of any kind is prohibited.

1.2 General safety information

1.2.1 Installation by skilled tradesmen only

The installation, inspection, maintenance and repair of the product, as well as the gas ratio settings, must only be carried out by a competent person.

1.2.2 Danger caused by improper operation

Improper operation may present a danger to you and others, and cause material damage.

- ▶ Carefully read the enclosed instructions and all other applicable documents, particularly the "Safety" section and the warnings.
- ▶ Only carry out the activities for which instructions are provided in these operating instructions.

1.2.3 Risk of death due to changes to the product or the product environment

- ▶ Never remove, bridge or block the safety devices.
- ▶ Do not tamper with any of the safety devices.
- ▶ Do not damage or remove any tamper-proof seals on components.
- ▶ Do not make any changes:
 - The product itself
 - The water and electricity supply lines
 - to the expansion relief valve
 - to the drain pipework
 - to constructional conditions that may affect the operational reliability of the product

1.2.4 Risk of injury and material damage due to maintenance and repairs carried out incorrectly or not carried out at all

- ▶ Never attempt to carry out maintenance work or repairs on your product yourself.
- ▶ Faults and damage should be immediately eliminated by a competent person.
- ▶ Adhere to the maintenance intervals specified.

1.2.5 Risk of burns or scalding caused by hot parts

Parts of the product become hot during operation.

- ▶ Only touch the product and its parts once these have cooled down.

1.2.6 Risk of material damage caused by frost

- ▶ Ensure that the heating installation always remains in operation during freezing conditions and that all rooms are sufficiently heated.
- ▶ If you cannot ensure the operation, have a competent person drain the heating installation.

2 Notes on the documentation

2.1 Observing other applicable documents

- ▶ Always observe all operating instructions enclosed with the installation components.

2.2 Storing documents

- ▶ Store these instructions and all other applicable documents for further use.

2.3 Validity of the instructions

These instructions apply only to:

Product article number

Validity: Not Pre-plumbed

VIH RW GB 150 BES	0010019224
VIH RW GB 200 BES	0010019225
VIH RW GB 250 BES	0010019226
VIH RW GB 300 BES	0010019227

Product article number

Validity: Pre-plumbed

VIH RW GB 150 BES	0010019230
VIH RW GB 200 BES	0010019231
VIH RW GB 250 BES	0010019232
VIH RW GB 300 BES	0010019233

2.4 Benchmark



Vaillant is a licensed member of the Benchmark Scheme which aims to im-

prove the standards of installation and commissioning of domestic heating and hot water systems in the UK and to encourage regular servicing to optimise safety, efficiency and performance.

Benchmark is managed and promoted by the Heating and Hotwater Industry Council. For more information visit www.benchmark.org.uk.

- ▶ Please ensure that the installer has fully completed the Benchmark Checklist on the inside back pages of the installation instructions supplied with the product and that you have signed it to say that you have received a full and clear explanation of its operation. The installer is legally required to complete a commissioning checklist as a means of complying with the appropriate Building Regulations (England and Wales).

All installations must be notified to Local Area Building Control either directly or through a Competent Persons Scheme. A Building Regulations Compliance Certificate will then be issued to the customer who should, on receipt, write the Notification Number on the Benchmark Checklist.

This product should be serviced regularly to optimise its safety, efficiency and performance. The service engineer should complete the relevant Service Record on the Benchmark Checklist after each service.

The Benchmark Checklist will be required in the event of any warranty.

3 Product description

3.1 Serial number

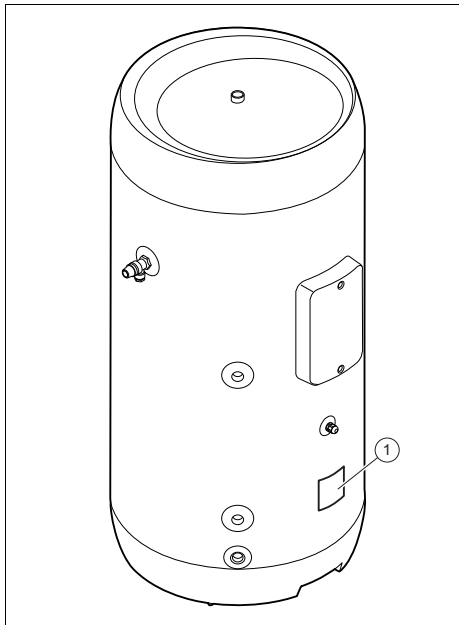

You can find the serial number on the data plate (1), which is located on the cylinder below the electronics box.

3.2 Information on the data plate

The data plate is attached to the product at the factory.

The data plate keeps record of the country in which the product is to be installed.

This product meets the requirements of standard EN 12897:2016.

3.3 CE marking



The CE marking shows that the products comply with the basic requirements of the applicable directives as stated on the declaration of conformity.

The declaration of conformity can be viewed at the manufacturer's site.

3.4 Hot Water Association

Vaillant is a full member of the Hot Water Association and promotes the scheme in association with its cylinder range. Details are available on the web site www.vaillant.co.uk



4 Function

4.1 Setting the domestic hot water temperature

Condition: With control

- Observe the instructions for the control. Depending on the control, you can set the domestic hot water temperature on the control.

Condition: Without control

- Consult your competent person to adjust the domestic hot water temperature on the cylinder.

4.2 Switching off the hot water generation

- Switch off the heat generator or the hot water generation at the heat generator or at the controller.

5 Troubleshooting

5.1 Detecting and eliminating faults

- If problems occur whilst operating the product, you can carry out certain self-checks with the aid of the table in the appendix.

Troubleshooting (→ Page 9)

- ▶ If the product is not functioning correctly, even though you have checked the points listed in the table, contact a competent person to carry out troubleshooting.

6 Care and maintenance

6.1 Maintenance

An annual inspection of the product carried out by a competent person is a prerequisite for ensuring that the product is permanently ready and safe for operation, reliable, and has a long working life.

6.2 Caring for the product

- ▶ Clean the casing with a damp cloth and a little solvent-free soap.
- ▶ Do not use sprays, scouring agents, detergents, solvents or cleaning agents that contain chlorine.

7 Decommissioning

7.1 Temporarily decommissioning the product

- ▶ Temporarily decommission the product only if there is no risk of frost.
- ▶ Switch off the heat generator or the hot water generation at the heat generator or at the controller.

7.2 Permanently decommissioning the product

- ▶ Employ a competent person to permanently decommission the product.

8 Recycling and disposal

- ▶ The competent person who installed your product is responsible for the disposal of the packaging.

Disposing of the product



■ If the product is labelled with this mark:

- ▶ In this case, do not dispose of the product with the household waste.
- ▶ Instead, hand in the product to a collection centre for waste electrical or electronic equipment.

Disposing of batteries



■ If the product contains batteries that are labelled with this mark:

- ▶ In this case, dispose of the batteries at a collection point for batteries.
 - ◁ **Prerequisite:** The batteries can be removed from the product without causing any destruction. Otherwise, the batteries are disposed of together with the product.
- ▶ In accordance with the legal regulations, used batteries must be returned since batteries may contain substances that are harmful to health and the environment.

9 Guarantee and customer service

9.1 Guarantee

Vaillant provide a full parts and labour guarantee for this appliance - please see guarantee card for details.

The appliances must be installed in accordance with The Water Regulations of:

- England and Wales: Water (supply and fittings) Regulations 1999 within England and Wales
- Scotland: The Water Byelaws

- Eire: Compliance with IS standards and Local Council regulations

Compliance with the Building regulations:

- England and Wales
- Scotland
- Northern Ireland
- Eire

Terms and conditions apply to the guarantee, details of which can be found on the guarantee registration card included with this appliance.

Failure to install and commission this appliance in compliance with the manufacturer's instructions will invalidate the guarantee (this does not affect the customer's statutory rights).

9.2 Customer service

For contact details for our customer service department, you can write to the address that is provided on the back page, or you can visit www.vaillant.co.uk.

Appendix

A Troubleshooting

Fault	Solution
Leak at the product	If possible, catch the liquid in a vessel and inform a competent person.
A fault code appears on the controller.	Inform a competent person.
Hot water temperature too low.	Check the hot water temperature setting on the controller and check whether the heat generator has been switched on. If the problem persists, inform a competent person.
Leak at the expansion relief valve.	Inform a competent person.

Index

A

Article number 6

B

Battery 7

C

CE marking 6

D

Data plate 6

Decommissioning 7

 Permanently 7

Disposal 7

Documents 5

F

Frost 4

I

Intended use 3

Isolator devices 7

M

Maintenance 4, 7

P

Product

 Permanently decommissioning 7

R

Recycling 7

Repair 4

S

Serial number 6

Setting the cylinder temperature 6

Switching off 7

T

Troubleshooting 6

Supplier**Vaillant Ltd.**

Nottingham Road ■ Belper ■ Derbyshire ■ DE56 1JT

Telephone 0330 100 3143

info@vaillant.co.uk ■ www.vaillant.co.uk



0020221763_03

Publisher/manufacture**Vaillant GmbH**

Berghauser Str. 40 ■ D-42859 Remscheid

Tel. +49 2191 18 0 ■ Fax +49 2191 18 2810

info@vaillant.de ■ www.vaillant.de

© These instructions, or parts thereof, are protected by copyright and may be reproduced or distributed only with the manufacturer's written consent.

Subject to technical modifications.