

Repeater

en

SR 52

0010048395

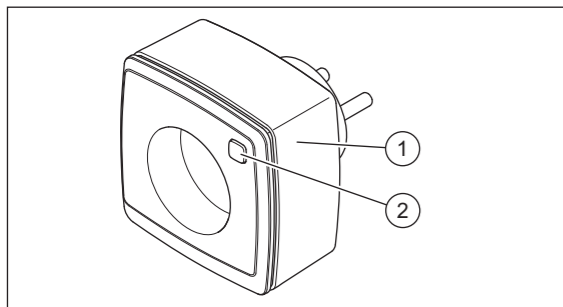

- 1 Repeater
- 2 System button

Technical data

Supply voltage	230 V ac/50 Hz
Max. load current of the plug socket	≤ 10 A
Power consumption in standby mode	< 0,3 W
Protection class	I
IP rating	IP20
Pollution degree	2
Permissible environmental temperature	-10 ... 35 °C
Height	70 mm
Width	70 mm
Depth	39 mm
Weight	154 g
Transmission frequency	868,00 - 868,60 MHz 869,40 - 869,65 MHz
Maximum transmission power	< 25 mW
Receiver category	SRD category 2
Range outdoors	400 m
Duty Cycle	< 1% per hr (868,00 - 868,60 MHz) < 10% per hr (869,40 - 869,65 MHz)
Rated surge voltage	2500 V

en

1 Safety

1.1 Intended use

In the event of inappropriate or improper use, damage to the product and other property may arise. You can use the repeater to extend the range of suitable gateways to compatible thermostats.

Intended use includes the following:

- observance of accompanying operating, installation and maintenance instructions for the product and any other system components
- installing and setting up the product in accordance with the product and system approval
- compliance with all inspection and maintenance conditions listed in the instructions.

This product can be used by children aged from 8 years and above and persons with reduced physical, sensory or mental capabilities or lack of experience and knowledge if they have been given supervision or instruction concerning use of the product in a safe way and understand the hazards involved. Children must not play with the product. Cleaning and user maintenance work must not be carried out by children unless they are supervised.

Intended use also covers installation in accordance with the IP code.

Any other use that is not specified in these instructions, or use beyond that specified in this document, shall be considered improper use. Any direct commercial or industrial use is also deemed to be improper.

Caution.

Improper use of any kind is prohibited.

1.2 General safety information

Risk of death from electric shock!

Opening the product may lead to a lethal electric shock. The product does not contain any parts that need to be maintained by the end user.

- The product must only be opened by a competent person.
- If the product shows signs of damage from the outside, e.g. on the housing, on control elements, on the connection ports, or a malfunction occurs, the product must not be used.
- In the event of a fault, have the product checked by a competent person.

Danger caused by improper operation

Improper operation may present a danger to you and others, and cause material damage.

- Carefully read the enclosed instructions and all other applicable documents, particularly the "Safety" section and the warnings.
- Only carry out the activities for which instructions are provided in these operating instructions.

Risk of material damage caused by unsuitable environmental conditions.

The electronics may be damaged if you install the product in an unsuitable environment.

- Only install the product in dry, dust-free interior rooms.
- Ensure that the product is not exposed to constant solar or heat irradiation, vibrations or mechanical loads.

Risk of material damage caused by an unsuitable plug socket.

- Use the product only in permanently installed earthed plug sockets, and not in socket strips or with extension cables.
- You cannot insert any further intermediate plugs into the product.

Risk of material damage due to lightning and overvoltage.

- Do not install the product during a lightning storm.
- Disconnect the product from the power grid during a lightning storm.

Risk of material damage caused by a missing on/off switch.

The product does not have an on/off switch and therefore has to be disconnected from the power grid.

- Only insert the product in a plug socket that is easy to access.

Risk of material damage caused by electrical overload.

An overload may damage the product beyond repair, lead to a fire or lead to an electrical accident.

- Before connecting a consumer, observe the product's technical data, particularly the maximum power consumption of the consumers that are being connected.
- Only load the product up to the specified power limit.

Regulations (directives, laws, standards)

- Observe the national regulations, standards, directives, ordinances and laws.

2 Notes on the documentation

- Always observe all the operating and installation instructions included with the system components.
- Store these instructions and all other applicable documents for further use.

3 Product description

3.1 Flashing sequence of the signal LED

Flashing sequence	Meaning	Explanation/required activity
Permanently lights up green	System button has been pressed. Function test active.	Press the system button again to end the function test.
Brief period of flashing orange	Radio transmission/transmission attempt/data transmission	Wait until the transmission has ended.
1 x long period of lighting up green	Process confirmed	You can continue with the operation.
1 x long period of lighting up red	Process failed or duty cycle limit reached	Try again.
Brief period of flashing orange (every 10 seconds)	Pairing mode active	Press the button for the Wi-Fi gateway (MiGo Link)
6 x long period of flashing red	Product defective	Note the display in your app or contact your specialist dealer.

Flashing sequence	Meaning	Explanation/required activity
Lights up 1 x orange and 1 x green (after plugging into the plug socket)	Test display	Once the test display goes out, you can continue.
Long and brief period of flashing orange (alternating)	Update to the unit software (OTAU = Over the Air Update)	New software is transferred. (Duration: Up to 12 hrs) This does not affect how the product works during this time.

3.2 CE marking

 The CE marking shows that the products comply with the basic requirements of the applicable directives as stated on the declaration of conformity.

The manufacturer hereby declares that the type of radio equipment that is described in these instructions complies with Directive 2014/53/EU. marking shows that the products comply with the basic requirements of the applicable directives as stated on the declaration of conformity.

<http://www.vaillant-group.com/doc/doc-radio-equipment-directive/>

3.3 MiGo Link

Condition: The Wi-Fi gateway is already connected to the Internet.

- Press the button beside the LED on the Wi-Fi gateway once briefly and plug the repeater into the plug socket.
 - The product automatically connect to each other and the repeater is displayed in the app.
- A maximum of one repeater can be operated in a radio network.

4 Operation

4.1 Behaviour following a voltage recovery

After inserting the product into a plug socket or recovering the mains voltage, the product carries out a self-test/restart (approx. 2 sec.). The LED briefly flashes orange and green (LED test indicator). Any fault that occurs here is displayed by the LED flashing. If there is a fault, the self-test is repeated and the product does not perform its intended function.

5 Troubleshooting

5.1 Command not confirmed

If at least one wireless subscriber does not confirm a command, the signal LED lights up red once the incorrect transmission is completed.

The reason for the incorrect transmission may be radio interference caused by one of the following:

- Wireless subscriber cannot be reached → Select a different location for the repeater. Structural elements and faults, e.g. other wireless products, may affect the range.
- Wireless subscriber cannot implement the command (load failure, etc.)
- Wireless subscriber defective

5.2 Reset to factory settings



Note
All settings will be lost.

1. Remove the product from the plug socket.
2. Plug the product back into the plug socket, and press and hold the system button for four seconds at the same time until the signal LED starts to rapidly flash orange.
3. Release the system button.
4. Press the system button again for four seconds until the signal LED lights up green.
5. Release the system button to complete the process of restoring the factory settings.
 - The product restarts.

6 Decommissioning

6.1 Decommissioning the product

1. Delete the product in the app.
2. Reset the product to its factory settings.
3. Remove the product from the plug socket.

6.2 Recycling and disposal



If the product is labelled with this mark:

- In this case, do not dispose of the product with the household waste.
- Instead, hand in the product to a collection centre for waste electrical or electronic equipment.

7 Customer service

The contact details for our customer service are provided on our website.

