

Advance Boiler Protection Kit



The Advance Boiler Protection Kit from Vaillant is made from the highest quality brass, to a unique design by Vaillant's UK engineering team. It has been designed to specifically complement the ecoFIT range of appliances and can cope with all outputs, right up to the powerful 35kW models.

Our engineers have designed the filter so that it can fit horizontally onto the pipework, close to the bottom of the boiler in tight spaces, making it a very discreet solution that protects the boiler and keeps it functioning more efficiently, for longer.

The Advance Boiler Protection Kit is supplied with a 22mm isolation valve for simple and quick drain-down of the filter for maintenance and cleaning. It has a maximum operating pressure of three bar.



Key features and benefits

- **Horizontal fitting**
Designed to be sited horizontally for a discreet, space saving fit
- **High-quality brass design**
The body of the filter has a superior brass construction
- **Compact design**
Barely visible when installed, offering flexibility for siting
- **Quick servicing**
Easy to dismantle, so the magnet shield can be easily removed for quicker cleaning
- **800 micron stainless steel non-ferrous filter**
Hard wearing stainless steel mesh that collects non-magnetic debris and blocks sludge from entering the boiler
- **Limitless installation orientations**
Suitable for boilers located in any situation

- **Compatible with water and water/glycol mixes**
Perfect for boilers installed in cold situations where glycol has been added to protect from freezing
- **500 ml volume capacity**
Allows for easy dosing of chemicals
- **Advanced magnetizing process**
Exerts its magnetic power in a wider region, even when full, for fully optimised filtration efficiency that averages over 80%, even when the magnet is fully covered
- **Standard 3/4" drain point connection**
Can connect to a standard hose, so the drain point can also be used for dosing. The unique sealing ring and swivel head allows it to rotate without leaking for easier serviceability
- **Maximum operating temperature 90°C**
Ideal for modern systems as well as older, high temperature systems

Technical data	Unit of measure	Advance Boiler Protection Kit
		22mm fitting only
		0010035819
A	mm	194
B	mm	22
C	mm	18
D	mm	176
E	mm	105
F	mm	28

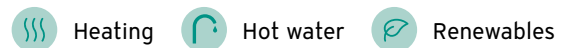
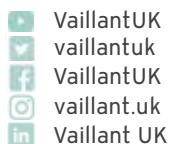
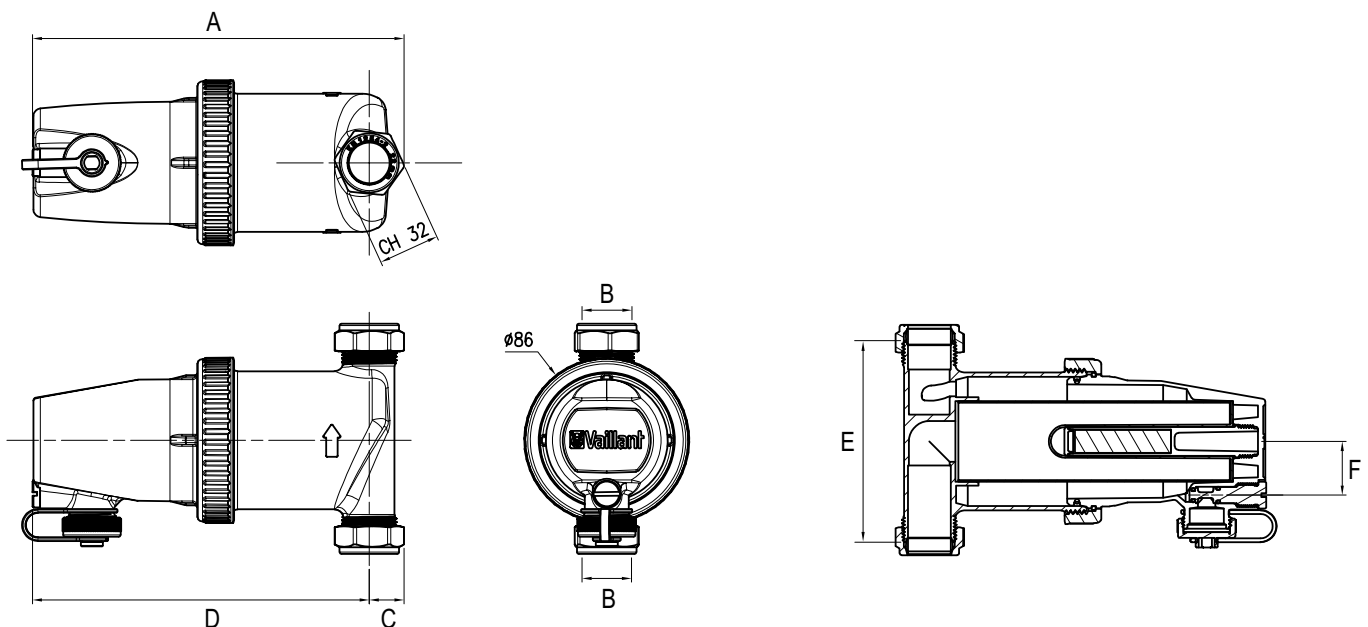

Vaillant Group UK Ltd.
Nottingham Road, Belper, Derbyshire DE56 1JT
Telephone 0345 602 2922
www.vaillant.co.uk
info@vaillant.co.uk