

Hydraulic station

VWL 57 ... 127/5 IS

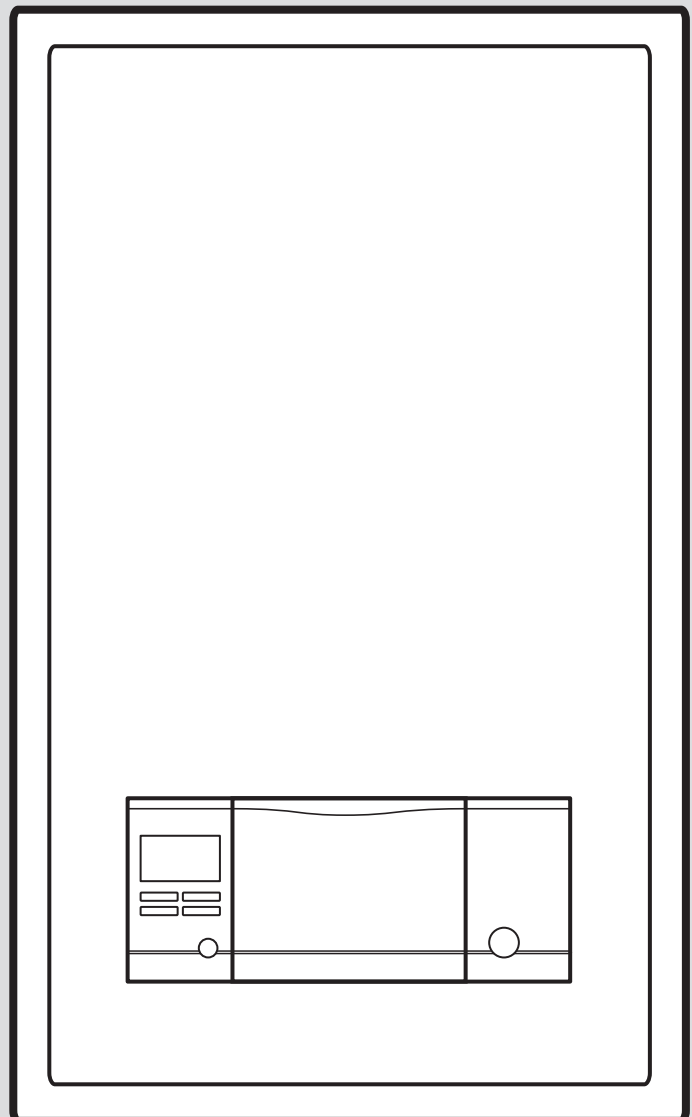

en	Operating instructions	3
en	Installation and maintenance instructions.....	16

Operating instructions

Contents

1	Safety	4
1.1	Intended use	4
1.2	General safety information	4
2	Notes on the documentation	6
3	Product description	6
3.1	Heat pump system	6
3.2	Design of the product	6
3.3	Control elements	6
3.4	Control panel	7
3.5	Description of the symbols	7
3.6	Functional description of buttons	7
3.7	Type designation and serial number	7
3.8	CE marking	8
3.9	Fluorinated greenhouse gases	8
3.10	Safety devices	8
4	Operation	8
4.1	Basic display	8
4.2	Operating concept	8
4.3	Menu display	8
4.4	Starting up the product	9
4.5	Setting the heating flow temperature	10
4.6	Setting the domestic hot water temperature	10
4.7	Switching off the product's functions	10
5	Care and maintenance	11
5.1	Caring for the product	11
5.2	Maintenance	11
5.3	Reading maintenance messages	11
5.4	Checking the filling pressure of the heating installation	11
6	Troubleshooting	11
6.1	Reading fault messages	11
6.2	Detecting and eliminating faults	11
7	Decommissioning	11
7.1	Temporarily decommissioning the product	11
7.2	Permanently decommissioning the product	11
8	Recycling and disposal	12
8.1	Arranging disposal of refrigerant	12
9	Guarantee and customer service	12
9.1	Guarantee	12
9.2	Customer service	12
	Appendix	13
A	Troubleshooting	13
B	Overview of the end user operating level	13
	Index	15



1 Safety

1.1 Intended use

There is a risk of injury or death to the user or others, or of damage to the product and other property in the event of improper use or use for which it is not intended.

The product is the indoor unit of an air-to-water heat pump with split technology.

The product uses the outdoor air as a heat source and can be used to heat a residential building and for domestic hot water generation.

The product is intended exclusively for domestic use.

The intended use only allows for these product combinations:

Outdoor unit	Indoor unit
VWL ..5/5 AS ...	VWL ..7/5 IS ...

Intended use includes the following:

- observance of the operating instructions included for the product and any other installation components
- compliance with all inspection and maintenance conditions listed in the instructions.

This product can be used by children aged from 8 years and above and persons with reduced physical, sensory or mental capabilities or lack of experience and knowledge if they have been given supervision or instruction concerning use of the product in a safe way and understand the hazards involved. Children must not play with the product. Cleaning and user maintenance work must not be carried out by children unless they are supervised.

Any other use that is not specified in these instructions, or use beyond that specified in this document, shall be considered improper use. Any direct commercial or industrial use is also deemed to be improper.

Caution.

Improper use of any kind is prohibited.

1.2 General safety information

1.2.1 Danger caused by improper operation

Improper operation may present a danger to you and others, and cause material damage.

- ▶ Carefully read the enclosed instructions and all other applicable documents, particularly the "Safety" section and the warnings.
- ▶ Only carry out the activities for which instructions are provided in these operating instructions.

1.2.2 Risk of death due to changes to the product or the product environment

- ▶ Never remove, bridge or block the safety devices.
- ▶ Do not tamper with any of the safety devices.
- ▶ Do not damage or remove any tamper-proof seals on components.
- ▶ Do not make any changes:
 - The product itself
 - The water and electricity supply lines
 - to the expansion relief valve
 - to the drain pipework
 - to the air inlets and air outlets
 - to the pipelines for the air supply and air exhaust
 - to constructional conditions that may affect the operational reliability of the product

1.2.3 Risk of injury from burns caused by touching refrigerant pipes

The refrigerant pipes between the outdoor unit and the indoor unit may become extremely hot during operation. There is a risk of burns.

- ▶ Do not touch any uninsulated refrigerant pipes.

1.2.4 Risk of injury from freezing caused by touching refrigerant

The product is delivered with an operational filling of R410A refrigerant. Escaping refrigerant may cause freezing if the exit point is touched.

- ▶ If refrigerant escapes, do not touch any components of the product.



- ▶ Do not inhale any vapours or gases that escape from the refrigerant circuit as a result of leaks.
- ▶ Avoid skin or eye contact with the refrigerant.
- ▶ In the event of skin or eye contact with the refrigerant, seek medical advice.

1.2.5 Risk of injury and material damage due to maintenance and repairs carried out incorrectly or not carried out at all

- ▶ Never attempt to carry out maintenance work or repairs on your product yourself.
- ▶ Faults and damage should be immediately eliminated by a competent person.
- ▶ Adhere to the maintenance intervals specified.

1.2.6 Risk of material damage caused by frost

- ▶ Ensure that the heating installation always remains in operation during freezing conditions and that all rooms are sufficiently heated.
- ▶ If you cannot ensure the operation, have a competent person drain the heating installation.

1.2.7 Risk of environmental damage caused by R410A refrigerant

The product contains the refrigerant R410A. The refrigerant must not be allowed to escape into the atmosphere. R410A is a fluorinated greenhouse gas covered by the Kyoto Protocol, with a GWP of 2088 (GWP = Global Warming Potential). If R410A escapes into the atmosphere, its impact is 2088 times greater than the natural greenhouse gas CO₂.

Before the product is disposed of, the refrigerant that is contained in it must be completely drained into a suitable vessel so that it can then be recycled or disposed of in accordance with regulations.

- ▶ Ensure that only an officially certified competent person with appropriate protective equipment carries out installation or maintenance work or any other form of intervention on the refrigerant circuit.
- ▶ Arrange for the refrigerant that is contained in the product to be recycled or disposed

of by a certified competent person in accordance with the regulations.

1.2.8 Benchmark



Vaillant is a licensed member of the Benchmark Scheme which aims to improve the standards of installation and commissioning of domestic heating and hot water systems in the UK and to encourage regular servicing to optimise safety, efficiency and performance.

Benchmark is managed and promoted by the Heating and Hotwater Industry Council. For more information visit www.benchmark.org.uk.

- ▶ Please ensure that the installer has fully completed the Benchmark Checklist on the inside back pages of the installation instructions supplied with the product and that you have signed it to say that you have received a full and clear explanation of its operation. The installer is legally required to complete a commissioning checklist as a means of complying with the appropriate Building Regulations (England and Wales).

All installations must be notified to Local Area Building Control either directly or through a Competent Persons Scheme. A Building Regulations Compliance Certificate will then be issued to the customer who should, on receipt, write the Notification Number on the Benchmark Checklist.

This product should be serviced regularly to optimise its safety, efficiency and performance. The service engineer should complete the relevant Service Record on the Benchmark Checklist after each service.

The Benchmark Checklist will be required in the event of any warranty.

2 Notes on the documentation

- ▶ Always observe all operating instructions that are enclosed with the installation components.
- ▶ Store these instructions and all other applicable documents for further use.

These instructions apply only to:

Product	Outdoor unit
VWL 57/5 IS	VWL 35/5 AS VWL 55/5 AS
VWL 77/5 IS	VWL 75/5 AS
VWL 127/5 IS	VWL 105/5 AS VWL 125/5 AS

3 Product description

3.1 Heat pump system

Design of a typical heat pump system with split technology:

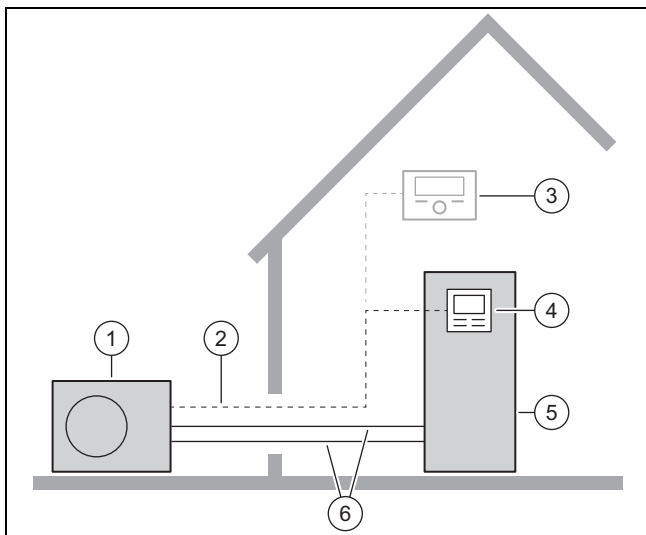

- | | |
|-----------------------------|-------------------------------|
| 1 Outdoor unit | 4 Control for the indoor unit |
| 2 eBUS line | 5 Indoor unit |
| 3 System control (optional) | 6 Refrigerant circuit |

3.2 Design of the product

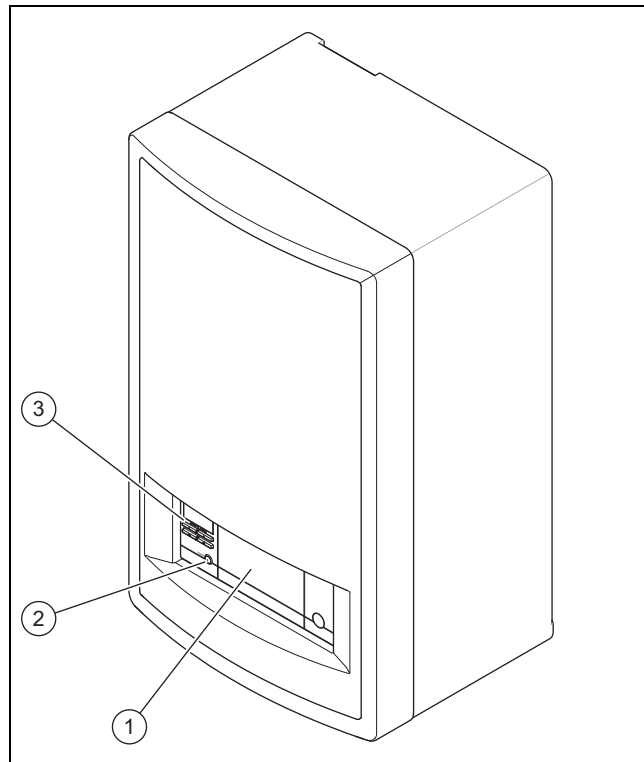

- | | |
|---|--------------------|
| 1 Optional installation site for the system control | 2 Reset button |
| | 3 Control elements |

3.3 Control elements

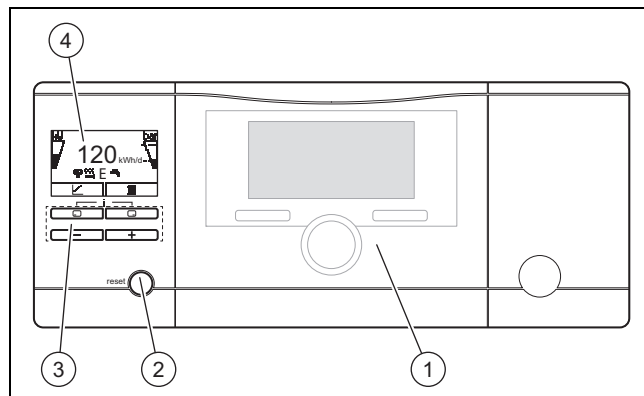

- | | |
|---------------------------------------|-----------------|
| 1 System control (optional accessory) | 3 Control panel |
| 2 Reset button | 4 Display |

3.4 Control panel

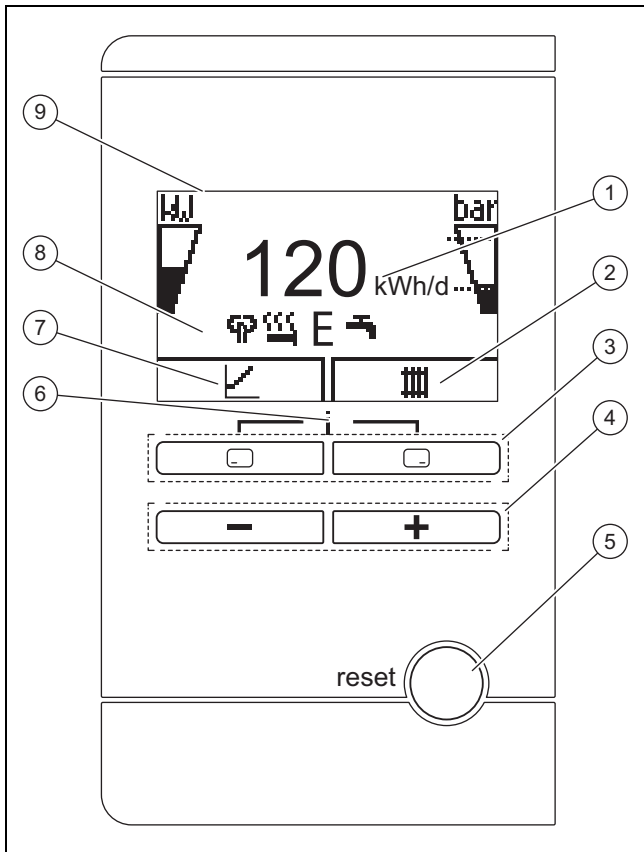

- | | | | |
|---|--|---|---|
| 1 | Displays the daily environmental energy yield | 6 | Access to the menu for additional information |
| 2 | Display of the current assignment of the right-hand selection button | 7 | Display of the current assignment of the left-hand selection button |
| 3 | Left- and right-hand selection buttons | 8 | Displays the symbols for the heat pump's current operating mode |
| 4 | − and + button | 9 | Display |
| 5 | Reset button, restart the product | | |

3.5 Description of the symbols

If you do not press any buttons within one minute, the light goes out.

Symbol	Meaning	Explanation
	Compressor power	<ul style="list-style-type: none"> Not filled: Compressor not in operation Partially filled: Compressor in operation. Partial load mode. Fully filled: Compressor in operation. Full load mode.
	Filling pressure in the heating circuit	<p>The dashed lines show the permitted range.</p> <ul style="list-style-type: none"> Displayed statically: Filling pressure in the permitted range Displayed flashing: Filling pressure outside of the permitted range
	Noise reduction mode	<ul style="list-style-type: none"> Operation with reduced sound emissions

Symbol	Meaning	Explanation
	Electric back-up heater	<ul style="list-style-type: none"> Displayed flashing: Electric back-up heater in operation Displayed together with the "Heating mode" symbol: Electric back-up heater active for heating mode Displayed together with the "Domestic hot water generation" symbol: Electric back-up heater active for domestic hot water mode
	eco mode	<ul style="list-style-type: none"> Energy-saving domestic hot water mode
	Heating mode	<ul style="list-style-type: none"> Heating mode active
	Domestic hot water generation	<ul style="list-style-type: none"> Domestic hot water mode active
	Cooling mode	<ul style="list-style-type: none"> Cooling mode active
 F.XXX	Fault condition	<ul style="list-style-type: none"> Appears instead of the basic display, may be an explanatory plain text display

3.6 Functional description of buttons

The two selection buttons are soft keys, meaning that they can be assigned different functions.

Button	Meaning
	<ul style="list-style-type: none"> – Cancelling the change to a set value or activating an operating mode – Calling up a higher selection level in the menu
	<ul style="list-style-type: none"> – Confirming a set value or activating an operating mode – Calling up a lower selection level in the menu
	Calling up the additional functions
	<ul style="list-style-type: none"> – Navigating between individual menu items – Increasing or decreasing the chosen set value

Adjustable values flash in the display.

You must always confirm a change to a value. Only then is the new setting saved. You can press to cancel a process at any time. If you do not press any buttons for longer than 15 minutes, the display returns to the basic display.

3.7 Type designation and serial number

The type designation and serial number are on the data plate.

3.8 CE marking



The CE marking shows that the products comply with the basic requirements of the applicable directives as stated on the declaration of conformity.

The declaration of conformity can be viewed at the manufacturer's site.

3.9 Fluorinated greenhouse gases

The product contains fluorinated greenhouse gases.

3.10 Safety devices

3.10.1 Frost protection function

The frost protection function for the system is controlled using the product itself or using the optional system control. If the system control fails, the product guarantees limited frost protection for the heating circuit.

3.10.2 Low-water pressure protection

This function continuously monitors the heating water pressure in order to prevent a possible loss of heating water.

3.10.3 Freeze protection

This function prevents the outdoor unit's evaporator from freezing when the heat source temperature drops below a certain value.

The outlet temperature of the heat source is constantly measured. If the outlet temperature of the heat source falls below a certain value, the compressor temporarily switches off and displays a status message. If this fault occurs three times in a row, it is switched off and a fault message is displayed.

3.10.4 Pump blocking protection

This function prevents the pumps for heating water from sticking. The pumps, which were out of operation for 23 hours, are switched on for 10–20 seconds, one after the other.

3.10.5 Hot gas thermostat in the refrigerant circuit

The hot gas thermostat shuts down the heat pump if the temperature in the refrigerant circuit is too high. Following a waiting period, the heat pump attempts to start once more. After three failed start attempts in succession, a fault message is displayed.

- Max. refrigerant circuit temperature: 135 °C
- Waiting period: 5 minutes (after the first occurrence)
- Waiting period: 30 minutes (after the second and every further occurrence)

The fault counter is reset if both of the following conditions are met:

- Heat requirement without switching off prematurely
- 60 minutes of uninterrupted operation

3.10.6 Safety cut-out (SCO) in the heating circuit

If the temperature in the heating circuit of the internal electric back-up heater exceeds the maximum temperature, the safety cut-out shuts down the electric back-up heater as a securing measure. After it is triggered, the safety cut-out must be replaced.

- Max. heating circuit temperature: 95 °C

4 Operation

4.1 Basic display

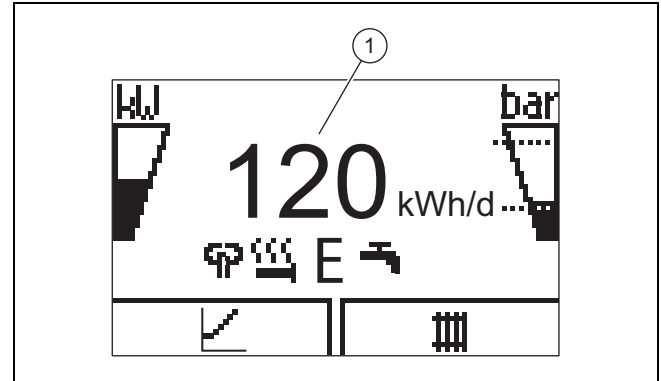

The displays shows the basic display with the current status of the product. The daily energy yield (1) is displayed in the centre of the display.

If you press a selection button, the activated function is displayed in the display.

As soon as a fault message is present, the basic displays switches to the fault message.

4.2 Operating concept

The product has two operating levels.

The operating level for the end user shows the most important information and offers setting options which do not require any special prior knowledge.

The operating level for the competent person is reserved for the competent person and is protected by a code.

Overview of the end user operating level (→ Appendix B)

4.3 Menu display

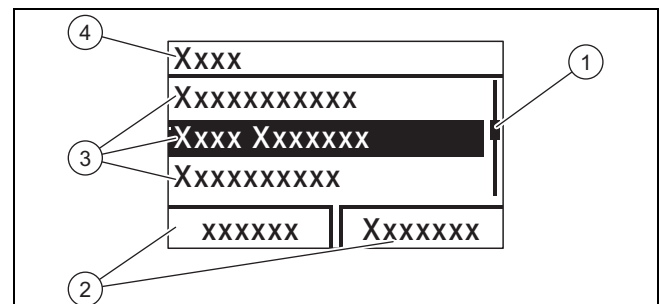

- | | | | |
|---|---|---|------------------------------|
| 1 | Scroll bar | 3 | Selection level list entries |
| 2 | Current assignment of the selection buttons | 4 | Selection level |



Note

Path details at the start of a section specify how to access this function, e.g. **Menu → Information → Contact details**.

4.4 Starting up the product

4.4.1 Opening the isolators

1. Ask the competent person who installed the product to explain to you where these isolators are located and how to handle them.
2. If installed, open the service valves in the heating installation's flow and return.
3. Open the cold-water isolation valve.

4.4.2 Switching on the product



Note

The product does not have an on/off switch. The product is switched on and ready for operation as soon as it is connected to the power grid. It can only be switched off using the partition that is installed on-site, e.g. fuses or circuit breaker in the utility connection box.

1. Ensure that the product casing has been installed.
2. Switch on the product via the fuses in the utility connection box.
 - ◁ The "basic display" is shown in the product's operating display.
 - ◁ The "basic display" may also be shown in the display for the optional system control.

4.4.3 Adjusting the target cylinder temperature



Danger!

Risk of death from legionella.

Legionella multiply at temperatures below 60 °C.

- ▶ Have a competent person inform you about the measures that should be taken to protect against Legionella in your installation.
- ▶ Do not set any water temperatures below 60 °C without consulting the competent person first.



Danger!

Risk of death from legionella!

If you decrease the cylinder temperature, the risk of legionella spreading increases.

- ▶ Activate the anti-legionella times in the system control and set them.

In order to achieve energy-efficient domestic hot water generation predominantly from the energy extracted from the environment, the factory setting for the desired domestic hot water temperature must be adjusted on the optional system control and/or on the heat pump's control panel.

Condition: System control connected

- ▶ To do this, adjust the target cylinder temperature (**Desired DHW circuit temperature**) to between 50 and 55 °C.
 - ◁ Depending on the source of energy obtained from the environment, domestic hot water outlet temperatures of between 50 and 55 °C are reached.
- ▶ Also switch on the electric back-up heater for the domestic hot water generation so that the required 60 °C can also be reached for the anti-legionella time programme.

Condition: No system control connected

- ▶ To do this, set the target cylinder temperature (**domestic hot water target cylinder temp.**) to 65 °C.



Note

If no system control is connected, the time programme for the anti-legionella function is not available. To still ensure anti-legionella function, the target cylinder temperature must therefore be set higher.

- ▶ Also switch on the electric back-up heater for the domestic hot water generation so that the required 60 °C can also be reached for the anti-legionella function.

4.4.4 Display of the energy consumption, energy yields and efficiencies

The product, the system control and the app show approximate values for energy consumption, energy yields and efficiencies, which are extrapolated based on calculation algorithms.

The values that are displayed in the app may differ from the other display options due to staggered transfer intervals.

The determined values depend on:

- Installation and system of the heating installation
- User behaviour
- Seasonal weather effects
- Various tolerances of unit-internal components

The recording of the values only includes the product in the factory-delivered condition. Supplementary accessories, even if they are installed on the product, as well as any other components in the heating system and other external consumers, are not part of the data recording.

Deviations between the determined values and the actual values may be significant. The determined values are therefore not suitable for creating or comparing energy billing, for example.

When replacing the PCB, the values for energy consumption, energy yields and efficiencies are reset in the heat pump's control panel.

4.4.5 Displaying the Live Monitor

Menu → Live Monitor

You can use the Live Monitor to view the current status of the product.

4.4.6 Displaying the building circuit pressure

Menu → Live Monitor → Building circuit pressure

You can use this function to display the current filling pressure of the heating installation.

4.4.7 Reading the operating statistics

Menu → Information → Heating op. hours

Menu → Information → DHW operating hours

Menu → Information → Cooling op. hours

Menu → Information → Total operating hours

You can use this function to display the operating hours for heating mode, for domestic hot water mode, for cooling mode and for overall operation.

4.4.8 Setting the language

- ▶ Press **OK** twice to confirm the set language and to avoid unintentionally changing it.
 - ▽ If you have accidentally set a language that you do not understand:
 - ▶ You can change the language as follows:
 - ▶ **Menu → Basic settings → Language.**
 - ▶ Select the required language.
 - ▶ Confirm the selection by pressing **OK**.

4.4.9 Set display contrast

Menu → Basic settings → Display contrast

- ▶ You can set the contrast here.

4.4.10 Serial number and article number

Menu → Information → Serial number

The product's serial number is displayed.

The article number is found in the second line of the serial number.



4.4.11 Contact details for the competent person

Menu → Information → Contact data Phone number

If the competent person has entered their telephone number during the installation, you can read it here.

4.5 Setting the heating flow temperature

Condition: No system control connected



- ▶ Press  in the basic display.
- ▶ Use  or  to change the value and confirm this.

Condition: System control connected

- ▶ Set the heating flow temperature on the system control, → System control operating instructions.

4.6 Setting the domestic hot water temperature

Condition: No system control connected

- ▶ Press  in the basic display.
- ▶ Use  or  to change the value and confirm this.

Condition: System control connected

- ▶ Set the domestic hot water temperature on the system control, → System control operating instructions.

4.7 Switching off the product's functions

4.7.1 Frost protection function



Caution.

Risk of material damage due to frost.

The frost protection function cannot guarantee circulation through the entire heating installation. Under certain circumstances, there is therefore a risk of frost to certain parts of the heating installation, which may cause damage.

- ▶ During a period of frost, ensure that the heating installation remains in operation and that all rooms are sufficiently heated, even when you are away.



To ensure that the frost protection devices are permanently ready for operation, you must leave the system switched on.

Another way to protect the heating installation and the product from frost for very long switch-off periods is to drain them completely.

- ▶ Consult a competent person about this.

4.7.2 Switching off heating mode (Summer mode)

Condition: No system control connected



- ▶ Press  in the basic display.
- ▶ Use  to change the value to zero and confirm this.

Condition: System control connected

- ▶ Switch off heating mode on the system control (summer mode), → System control operating instructions.

4.7.3 Switching off domestic hot water generation

Condition: No system control connected

- ▶ Press  in the basic display.
- ▶ Use  to set the value to zero and confirm this.

Condition: System control connected

- ▶ Switch off the domestic hot water generation at the system control (→ System control operating instructions).

5 Care and maintenance

5.1 Caring for the product

- ▶ Clean the casing with a damp cloth and a little solvent-free soap.
- ▶ Do not use sprays, scouring agents, detergents, solvents or cleaning agents that contain chlorine.

5.2 Maintenance

An annual inspection of the product carried out by a competent person is a prerequisite for ensuring that the product is permanently ready and safe for operation, reliable, and has a long working life.

5.3 Reading maintenance messages

If the  symbol is shown in the display, the product requires maintenance work or the product is in restricted mode (comfort protection). The product is not in fault mode; it continues to operate.

- ▶ Consult a competent person.

Condition: Lhm. 37 is displayed

The product is in Comfort protection mode. The product has detected a permanent fault and continues to run with restricted comfort.

5.4 Checking the filling pressure of the heating installation



Note

To avoid operating the installation with insufficient water volume and to prevent possible damage associated with this, the product is fitted with a pressure sensor and a digital pressure display.

To ensure that the heating installation operates properly, the filling pressure must be between 0.1 MPa and 0.15 MPa (1.0 bar and 1.5 bar) when the heating installation condition is cold.

If the heating installation extends over several storeys, a higher filling pressure may be required for the heating installation. Ask a competent person for details.



Note

If the pressure falls below 0.07 MPa (0.7 bar), message M32 appears.

If the pressure rises above 0.07 MPa (0.7 bar), message M32 goes out.

In addition, the  symbol is displayed after approx. one minute.

If the filling pressure of the heating installation falls below 0.05 MPa (0.5 bar) for longer than one minute, fault message F.22 and the current filling pressure appear alternately in the display.

If the blocking time has elapsed or if the filling pressure of the heating installation rises above 0.05 MPa (0.5 bar), fault message F.22 goes out.

1. Use **Menu** → **Live Monitor Water pressure** to display the filling pressure of the heating installation.
2. If the pressure drops frequently, identify and eliminate the reason for the pressure loss of heating water. Inform a competent person of this.

6 Troubleshooting

6.1 Reading fault messages

Fault messages have priority over all other displays and are shown on the display instead of the basic display. If several faults occur at the same time, these are displayed alternately for two seconds each.

Depending on the type of fault, the system can work in limp home mode in order to maintain the heating mode or domestic hot water generation.

F.723 Building circuit: Pressure too low

If the filling pressure falls below the minimum pressure, the heat pump will be switched off automatically.

- ▶ Inform your competent person so that he can top up the heating water.

F.1120 Heating rod: Phase failure

If the electric back-up heater is defective, the anti-legionella function is not guaranteed.

- ▶ Inform your competent person so that they can rectify the fault and reset the internal circuit breaker.

6.2 Detecting and eliminating faults

- ▶ If problems occur whilst operating the product, you can carry out certain checks with the aid of the table. Troubleshooting (→ Appendix A)
- ▶ If the product is not functioning correctly, even though you have checked the points listed in the table, contact a competent person.

7 Decommissioning

7.1 Temporarily decommissioning the product

- ▶ Use the partition that is installed on-site (e.g. fuses or power switches) to disconnect the product from the power supply.

7.2 Permanently decommissioning the product

- ▶ Have a competent person permanently decommission and dispose of the product.

8 Recycling and disposal

Disposing of the packaging

- ▶ The competent person who installed your product is responsible for the disposal of the packaging.

Disposing of the product



■ If the product is labelled with this mark:

- ▶ In this case, do not dispose of the product with the household waste.
- ▶ Instead, hand in the product to a collection centre for waste electrical or electronic equipment.

Deleting personal data

Personal data may be misused by unauthorised third parties.

If the product contains personal data:

- ▶ Ensure that there is no personal data on or in the product (e.g. online login details or similar) before you dispose of the product.

8.1 Arranging disposal of refrigerant

The product is filled with R410A refrigerant which must not be released into the atmosphere.

- ▶ Refrigerant must only be disposed of by an authorised competent person.
- ▶ Observe the general safety information.

9 Guarantee and customer service

9.1 Guarantee

Vaillant provides a full parts and labour guarantee for this appliance for the duration as shown on the enclosed registration card which must be fully completed and returned within 30 days of installation. All appliances must be installed by a suitably competent person fully conversant and in accordance with all current regulations applicable to the appliance type installation. In the case of gas appliances the Gas Safety (Installation and Use) Regulations 1998, and the manufacturer's instructions. In the UK competent persons approved at the time by the Health and Safety Executive undertake the work in compliance with safe and satisfactory standards. Installers should also be fully conversant with and competent with all necessary electrical and building regulations that may apply to the installation.

In addition all unvented domestic hot water cylinders must be installed by a competent person to the prevailing building regulations at the time of installation (G3). All appliances shall be fully commissioned in accordance with our installation manual and Benchmark commissioning check list (this will be included within the installation manual). These must be signed and given to the user for safe keeping during the hand over process. Installers should also at this time advise the user of the annual servicing requirements and advise of appropriate service agreement.

Terms and conditions do apply to the guarantee, details of which can be found on the registration card included with this appliance. In order to qualify for guarantee after one year the appliance must be serviced in accordance with our installation manual servicing instructions. The benchmark service history should be completed. Note - all costs associated with this service are excluded from this guarantee.

Failure to install and commission this appliance in compliance with the manufacturer's instructions will invalidate the guarantee (this does not affect the customer's statutory rights).

9.2 Customer service

For contact details for our customer service department, you can write to the address that is provided on the back page, or you can visit www.vaillant.co.uk.

Appendix

A Troubleshooting

Problem	Possible cause	Remedy
No domestic hot water, heating remains cold; product does not start up	Building power supply switched off	Switch on building power supply
	Domestic hot water or heating set to "off"/domestic hot water temperature or target temperature set too low	Ensure that domestic hot water mode and/or heating mode is activated in the system control. Set the domestic hot water temperature in the system control to the required value.
	Air in the heating installation	Purging the radiators If the problem occurs again: Inform the competent person
Domestic hot water mode without any problems; heating does not start	No heat requirement via the control	Check the timer programme on the control and correct if necessary Check the room temperature and, if required, correct the target room temperature (→ Control operating instructions)

B Overview of the end user operating level

Setting level	Values		Unit	Increment, select	Default setting	Setting
	Min.	Max.				
Basic display → Right-hand selection button						
Room temperature setpoint *	Current value		°C			
Manual cooling demand*						
Basic display → Left-hand selection button						
Domestic hot water cylinder target temperature*	Current value		°C			
Domestic hot water cylinder actual temperature	Current value		°C			
Yield indicator →						
Energy yield: Day, Heating	Cumulative value		kWh			
Energy yield: Day, Domestic hot water	Cumulative value		kWh			
Energy yield: Day, Cooling	Cumulative value		kWh			
Energy yield: Month, Heating	Cumulative value		kWh			
Working figure: Month, Heating	Cumulative value					
Energy yield: Total, Heating	Cumulative value		kWh			
Working figure: Total, Heating	Cumulative value					
Energy yield: Month, Cooling	Cumulative value		kWh			
Working figure: Month, Cooling	Cumulative value					
Energy yield: Total, Cooling	Cumulative value		kWh			
Working figure: Total, Cooling	Cumulative value					
Energy yield: Month, Domestic hot water	Cumulative value		kWh			
Working figure: Month, Domestic hot water	Cumulative value					
Energy yield: Total, Domestic hot water	Cumulative value		kWh			
Working figure: Total, Domestic hot water	Cumulative value					
Total energy consumption	Cumulative value		kWh			
Live Monitor →						
Current status message(s)	Current value					
Building circuit pressure	Current value		bar			
*If no system control is installed, the menu item is displayed in the product's control panel.						

Setting level	Values		Unit	Increment, select	Default setting	Setting
	Min.	Max.				
Heating circuit flow rate	Current value		l/h			
Switch-on delay Outdoor unit	Current value		min			
Switch-on delay Indoor unit	Current value		min			
Flow temp. setpoint	Current value		°C			
Current flow temp.	Current value		°C			
Energy integral	Current value		°min			
Cooling capacity	Current value		kW			
Electrical power consumption	Current value		kW	Total power consumption of the heat pump without any external components connected (as supplied).		
Compressor modulation	Current value					
Air inlet temperature	Current value		°C			
Immersion heater power	Current value		kW			
External current anode status	Current value					
Outdoor temperature	Current value		°C			
Information →						
Contact data	Phone number					
Serial number	Permanent value					
Operating hours total	Cumulative value		h			
Hours heating	Cumulative value		h			
DHW operating hours	Cumulative value		h			
Cooling op. hours	Cumulative value		h			
Basic settings →						
Language	Current language			Languages available for selection	02 English	
Display contrast	Current value			1	25	
	15	40				
Resets →						
No entries available						
*If no system control is installed, the menu item is displayed in the product's control panel.						

Index

A

Article number 10

B

Building circuit pressure 10

C

CE marking 8

Comfort protection mode 11

Competent person contact details 10

Control elements 6

Control panel 7

D

Decommissioning 11

Display 6–7

Disposal 12

Documents 6

Domestic hot water generation, switching off 10

Domestic hot water temperature, setting 10

F

Fault message 11

Filling pressure in the building circuit 11

Freeze protection 8

Frost 5

Frost protection function 8, 10

H

Heating flow temperature 10

Heating flow temperature, setting 10

Heating installation

 Draining 10

Heating mode, switching off 10

Hot gas thermostat 8

I

Intended use 4

L

Language 10

M

Maintenance 5, 11

Maintenance message 11

Menu 8

O

Operating concept 8

P

Product

 Switching on 9

Pump blocking protection 8

R

R410A refrigerant 5

Recycling 12

Repair 5

Restricted mode 11

S

Safety cut-out 8

Serial number 6, 10

Setting the display contrast 10

Summer mode 10

T

Troubleshooting 11

Installation and maintenance instructions

Contents

1	Safety	18	6.5	Opening the power supply PCB's electronics box	30
1.1	Intended use	18	6.6	Routing the cables in the product	30
1.2	General safety information	18	6.7	Establishing the power supply, 1~/230V	31
1.3	Regulations (directives, laws, standards)	20	6.8	Establishing the power supply, 3~/400V	32
1.4	Benchmark	20	6.9	Limiting the power consumption	33
2	Notes on the documentation	21	6.10	Installing the system control in the electronics box	33
2.1	Further information	21	6.11	Requirements for the eBUS line	33
3	Product description	21	6.12	Opening the control PCB's electronics box	33
3.1	Heat pump system	21	6.13	Routing the cables in the electronics box	33
3.2	Safety devices	21	6.14	Carrying out the wiring	34
3.3	Functions of the heat pump	22	6.15	Connecting the circulation pump	34
3.4	Description of the product	22	6.16	Connecting a limit thermostat for the underfloor heating	34
3.5	Product overview	22	6.17	Actuating a circulation pump with an eBUS control	35
3.6	Service valve	23	6.18	Connecting the domestic hot water cylinder	35
3.7	Serial number	23	6.19	Connecting the external prioritising diverter valve (optional)	35
3.8	Information on the data plate	23	6.20	Connecting the outdoor temperature sensor	35
3.9	Connection symbols	24	6.21	Connecting the VR 70/VR 71 wiring centre	35
3.10	CE marking	24	6.22	Connecting cascades	35
3.11	Application limits	24	6.23	Closing the electronics box for the power supply PCB	35
3.12	Buffer cylinder	25	6.24	Checking the electrical installation	35
3.13	Cooling mode	25	7	Operation	35
3.14	Display of the energy consumption, energy yields and efficiencies	25	7.1	Operating concept of the product	35
4	Set-up	25	8	Start-up	35
4.1	Unpacking the product	25	8.1	Setting the prioritising diverter valve	35
4.2	Checking the scope of delivery	25	8.2	Checking and treating the heating water/filling and supplementary water	36
4.3	Selecting the installation site	25	8.3	Filling and purging the heating installation	37
4.4	Dimensions	26	8.4	Purging	37
4.5	Minimum clearances and installation clearances	26	8.5	Switching on the product	38
4.6	Wall-mounting the product	26	8.6	Running the installation assistants	38
4.7	Removing the front casing	27	8.7	Menu functions without the optional system control	38
4.8	Removing the bottom casing	27	8.8	Energy balance control	38
5	Hydraulics installation	27	8.9	Compressor hysteresis	38
5.1	Carrying out the installation preparations	27	8.10	Enabling the electric back-up heater	39
5.2	Routing refrigerant pipes	28	8.11	Setting the anti-legionella function	39
5.3	Connecting the refrigerant pipes	28	8.12	Purging	39
5.4	Checking the refrigerant pipes for tightness	28	8.13	Calling up the installer level	39
5.5	Installing the heating flow and heating return for the domestic hot water cylinder	28	8.14	Restarting the installation assistants	39
5.6	Installing the building circuit connections	29	8.15	Checking the configuration	39
5.7	Installing a drain on the expansion relief valve	29	8.16	Calling up statistics	39
6	Electrical installation	29	8.17	Activating screed drying without the outdoor unit and without the system control	39
6.1	Preparing the electrical installation	29	8.18	Activating cooling mode	40
6.2	Requirements for the quality of the mains voltage	29	8.19	Starting up the optional system control	40
6.3	Electrical partition	30	8.20	Displaying the filling pressure in the building circuit	40
6.4	Installing components for the energy supply company lockout function	30	8.21	Checking function and leak-tightness	40

9	Adapting the unit to the heating installation.....	40	I	Fault codes.....	57
9.1	Configuring the heating installation	40	J	5.4 kW back-up heater.....	61
9.2	Remaining feed head of the product	41	K	8.54 kW back-up heater at 230 V.....	61
9.3	Setting the flow temperature in heating mode (with no control connected)	41	L	8.54 kW back-up heater at 400 V	62
9.4	Instructing the end user	41	M	Inspection and maintenance work.....	62
10	Troubleshooting	41	N	Characteristic values for the temperature sensor, refrigeration circuit.....	62
10.1	Contacting your service partner.....	41	O	Characteristic values for the internal temperature sensors, hydraulic circuit	63
10.2	Displaying the Live Monitor (current product status).....	41	P	Characteristic values for the VR10 internal temperature sensors, cylinder temperature	64
10.3	Checking fault codes	42	Q	Characteristic values for the VRC DCF outdoor temperature sensor.....	65
10.4	Querying the fault memory	42	R	Technical data.....	65
10.5	Resetting the fault memory.....	42	S	Commissioning Checklist.....	69
10.6	Using the function menu	42	Index	72	
10.7	Using check programmes.....	42			
10.8	Carrying out the actuator test	42			
10.9	Resetting parameters to factory settings	42			
10.10	Preparing the repair work	42			
10.11	Safety cut-out.....	42			
11	Inspection and maintenance	43			
11.1	Inspection and maintenance information.....	43			
11.2	Procuring spare parts	43			
11.3	Checking maintenance messages.....	43			
11.4	Observing inspection and maintenance intervals	43			
11.5	Preparing for inspection and maintenance	44			
11.6	Checking the pre-charge pressure of the expansion vessel	44			
11.7	Checking and correcting the filling pressure of the heating installation	44			
11.8	Checking the high-pressure switch-off	44			
11.9	Completing inspection and maintenance.....	44			
12	Draining	44			
12.1	Draining the product's heating circuit.....	44			
13	Decommissioning.....	45			
13.1	Temporarily decommissioning the product.....	45			
13.2	Permanently decommissioning the product.....	45			
14	Recycling and disposal.....	45			
14.1	Disposing of the packaging	45			
14.2	Disposing of the product and accessories	45			
14.3	Disposing of the refrigerant	45			
15	Customer service.....	45			
Appendix	46				
A	Wiring diagram.....	46			
B	Control PCB	47			
C	Basic connection diagram for the energy supply company lockout, shutdown via connection S21	48			
D	Basic connection diagram for the energy supply company lockout, shutdown via partition	49			
E	Installer level overview.....	50			
F	Status codes	54			
G	Maintenance messages	56			
H	Comfort protection mode.....	56			



1 Safety

1.1 Intended use

There is a risk of injury or death to the user or others, or of damage to the product and other property in the event of improper use or use for which it is not intended.

The product is the indoor unit of an air-to-water heat pump with split technology.

The product uses the outdoor air as a heat source and can be used to heat a residential building and for domestic hot water generation.

The product is intended exclusively for domestic use.

The intended use only allows for these product combinations:

Outdoor unit	Indoor unit
VWL ..5/5 AS ...	VWL ..7/5 IS ...

Intended use includes the following:

- observance of accompanying operating, installation and maintenance instructions for the product and any other system components
- installing and setting up the product in accordance with the product and system approval
- compliance with all inspection and maintenance conditions listed in the instructions.

Intended use also covers installation in accordance with the IP code.

Any other use that is not specified in these instructions, or use beyond that specified in this document, shall be considered improper use. Any direct commercial or industrial use is also deemed to be improper.

Caution.

Improper use of any kind is prohibited.

1.2 General safety information

1.2.1 Risk caused by inadequate qualifications

The following work must only be carried out by competent persons who are sufficiently qualified to do so:

- Set-up
- Dismantling
- Installation
- Start-up
- Inspection and maintenance
- Repair
- Decommissioning
- ▶ Proceed in accordance with current technology.

1.2.2 Risk of death from electric shock

There is a risk of death from electric shock if you touch live components.

Before commencing work on the product:

- ▶ Disconnect the product from the power supply by switching off all power supplies at all poles (electrical partition in over-voltage category III for full partition, e.g. fuse or circuit breaker).
- ▶ Secure against being switched back on again.
- ▶ Wait for at least 3 minutes until the capacitors have discharged.
- ▶ Check that there is no voltage.

1.2.3 Risk of death due to lack of safety devices

The basic diagrams included in this document do not show all safety devices required for correct installation.

- ▶ Install the necessary safety devices in the installation.
- ▶ Observe the applicable national and international laws, standards and directives.

1.2.4 Risk of burns, scalds and frostbite due to hot and cold components

There is a risk of burns and frostbite from some components, particularly uninsulated pipelines.

- ▶ Only carry out work on the components once these have reached environmental temperature.



1.2.5 Risk of being scalded by hot potable water

There is a risk of scalding at the domestic hot water draw-off points if the domestic hot water temperatures are greater than 50 °C. Young children and elderly persons are particularly at risk, even at lower temperatures.

- ▶ Select the temperature so that nobody is at risk.
- ▶ Inform the end user about the risk of scalding when the **Anti-legionella** function is switched on.

1.2.6 Risk of injury due to the heavy weight of the product

- ▶ Make sure that the product is transported by at least two people.

1.2.7 Risk of material damage due to an unsuitable installation surface

An uneven installation surface may cause leaks in the product.

- ▶ Make sure that the product is positioned flush against the installation surface.
- ▶ Ensure that the installation surface has sufficient load-bearing capacity to bear the operating weight of the product.

1.2.8 Risk of material damage due to malfunctioning

Not rectifying faults, changing the safety devices and failing to carry out maintenance can cause malfunctioning and pose safety risks during operation.

- ▶ Ensure that the heating installation is in a technically perfect condition.
- ▶ Ensure that no safety or monitoring devices have been removed, bridged or disabled.
- ▶ Immediately eliminate any faults and damage that may affect safety.

1.2.9 Preventing the risk of injury from freezing as a result of touching refrigerant

The refrigeration circuit for the indoor unit is delivered with an operational filling of nitrogen in order to guarantee a check for tightness. The outdoor unit is delivered with an operational filling of R410A refrigerant. Es-

caping refrigerant may cause freezing if the exit point is touched.

- ▶ If refrigerant escapes, do not touch any components of the product.
- ▶ Do not inhale any steam or gases that escape from the refrigerant circuit as a result of leaks.
- ▶ Avoid skin or eye contact with the refrigerant.
- ▶ In the event of skin or eye contact with the refrigerant, seek medical advice.

1.2.10 Risk of material damage caused by condensate inside the house

In heating mode, the lines between the heat pump and the heat source (environment circuit) are cold, which means that condensate may form on the lines in the house. In cooling mode, the lines in the building circuit are so cold that condensate may form if the temperature falls below the dew point. Condensate may lead to material damage, for example due to corrosion.

- ▶ Ensure that you do not damage the heat insulation on the lines.

1.2.11 Risk of material damage due to additional elements in the heating water

Unsuitable antifreeze and corrosion inhibitors may damage seals and other components of the heating circuit, and may therefore also cause water leaks.

- ▶ Only add approved antifreeze and corrosion inhibitors to the heating water.

1.2.12 Risk of material damage caused by frost



- ▶ Do not install the product in rooms prone to frost.

1.2.13 Risk of material damage caused by using an unsuitable tool

- ▶ Use the correct tool.

1.2.14 Risk of environmental damage caused by refrigerant

The product contains a refrigerant with considerable GWP (GWP = Global Warming Potential).

- 
- 
- ▶ Ensure that the refrigerant does not escape into the atmosphere.
 - ▶ If you are a competent person who is qualified to work with refrigerants, you must wear appropriate protective equipment when servicing the product, and access the refrigerant circuit, if required. Recycle or dispose of the product in accordance with the applicable regulations.

1.3 Regulations (directives, laws, standards)

- ▶ Observe the national regulations, standards, directives, ordinances and laws.

1.4 Benchmark

Vaillant is a licensed member of the Benchmark Scheme.

Benchmark places responsibilities on both manufacturers and installers. The purpose is to ensure that customers are provided with the correct equipment for their needs, that it is installed, commissioned and serviced in accordance with the manufacturer's instructions by a competent person approved at the time by the Health and Safety Executive and that it meets the requirements of the appropriate Building Regulations. The Benchmark Checklist can be used to demonstrate compliance with Building Regulations and should be provided to the customer for future reference.

Installers are required to carry out installation, commissioning and servicing work in accordance with the Benchmark Code of Practice which is available from the Heating and Hotwater Industry Council who manage and promote the Scheme.

Benchmark is managed and promoted by the Heating and Hotwater Industry Council.



For more information visit
www.centralheating.co.uk

2 Notes on the documentation

- ▶ Always observe all the operating and installation instructions included with the system components.
- ▶ Pass these instructions and all other applicable documents on to the end user.

These instructions apply only to:

Product	Outdoor unit
VWL 57/5 IS	VWL 35/5 AS VWL 55/5 AS
VWL 77/5 IS	VWL 75/5 AS
VWL 127/5 IS	VWL 105/5 AS VWL 125/5 AS

2.1 Further information



- ▶ Scan the displayed code using your smartphone in order to view further information about the installation.
 - ◀ You are guided to installation videos.

3 Product description

3.1 Heat pump system

Design of a typical heat pump system with split technology:

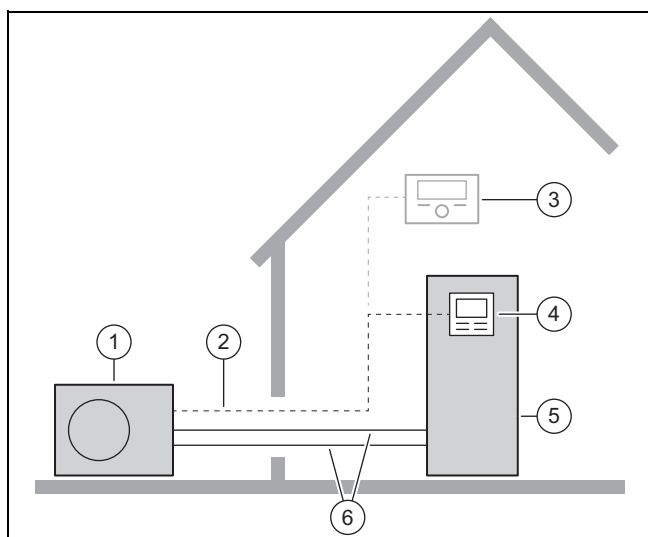

- | | | | |
|---|---------------------------|---|-----------------------------|
| 1 | Outdoor unit | 4 | Control for the indoor unit |
| 2 | eBUS line | 5 | Indoor unit |
| 3 | System control (optional) | 6 | Refrigerant circuit |

3.2 Safety devices

3.2.1 Frost protection function

The frost protection function for the system is controlled using the product itself or using the optional system control. If the system control fails, the product guarantees limited frost protection for the heating circuit.

3.2.2 Low-water pressure protection

This function continuously monitors the heating water pressure in order to prevent a possible loss of heating water. If the water pressure falls below the minimum pressure, an analogue pressure sensor switches off the product and switches the other modules, where these exist, to standby mode. The pressure sensor switches the product on again if the water pressure reaches the operating pressure.

If the pressure in the heating circuit is ≤ 0.1 MPa (1 bar), a maintenance message appears below the minimum operating pressure.

- Min. heating circuit pressure: ≥ 0.05 MPa (≥ 0.50 bar)
- Min. heating circuit operating pressure: ≥ 0.07 MPa (≥ 0.70 bar)

3.2.3 Pump blocking protection

This function prevents the pumps for heating water from sticking. The pumps, which were out of operation for 23 hours, are switched on for 10–20 seconds, one after the other.

3.2.4 Hot gas thermostat in the refrigerant circuit

The hot gas thermostat shuts down the heat pump if the temperature in the refrigerant circuit is too high. Following a waiting period, the heat pump attempts to start once more. After three failed start attempts in succession, a fault message is displayed.

- Max. refrigerant circuit temperature: 135 °C
- Waiting period: 5 minutes (after the first occurrence)
- Waiting period: 30 minutes (after the second and every further occurrence)

The fault counter is reset if both of the following conditions are met:

- Heat requirement without switching off prematurely
- 60 minutes of uninterrupted operation

3.2.5 Safety cut-out (SCO) in the heating circuit

If the temperature in the heating circuit of the internal electric back-up heater exceeds the maximum temperature, the safety cut-out shuts down the electric back-up heater as a securing measure. After it is triggered, the safety cut-out must be replaced.

- Max. heating circuit temperature: 95 °C

3.3 Functions of the heat pump

The heat pump has a closed refrigerant circuit in which refrigerant circulates.

In heating mode, cyclic evaporation, compression, liquefaction and expansion take in heat energy from the surroundings and transfer it to the building. In cooling mode, heat energy is extracted from the building and released into the environment.

3.3.1 Operating principle in heating mode

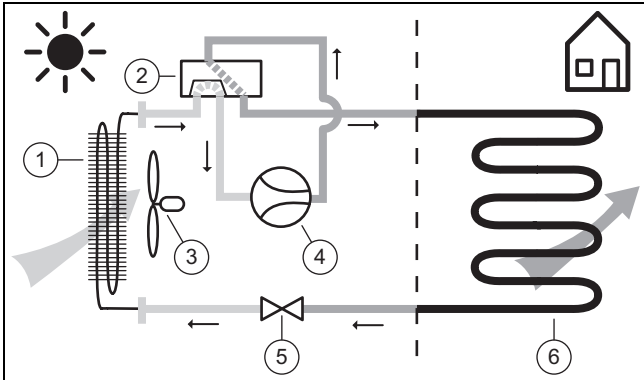

- | | | | |
|---|-----------------------|---|-----------------|
| 1 | Evaporator | 4 | Compressor |
| 2 | 4-port diverter valve | 5 | Expansion valve |
| 3 | Fan | 6 | Condenser |

3.3.2 Operating principle in cooling mode

Validity: Product with cooling mode

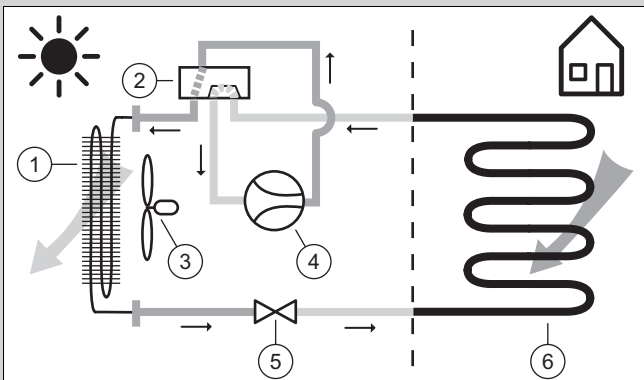

- | | | | |
|---|-----------------------|---|-----------------|
| 1 | Condenser | 4 | Compressor |
| 2 | 4-port diverter valve | 5 | Expansion valve |
| 3 | Fan | 6 | Evaporator |

3.4 Description of the product

The product is the indoor unit of an air-to-water heat pump with split technology.

The indoor unit is connected to the outdoor unit via the refrigerant circuit.

3.5 Product overview

3.5.1 Product design

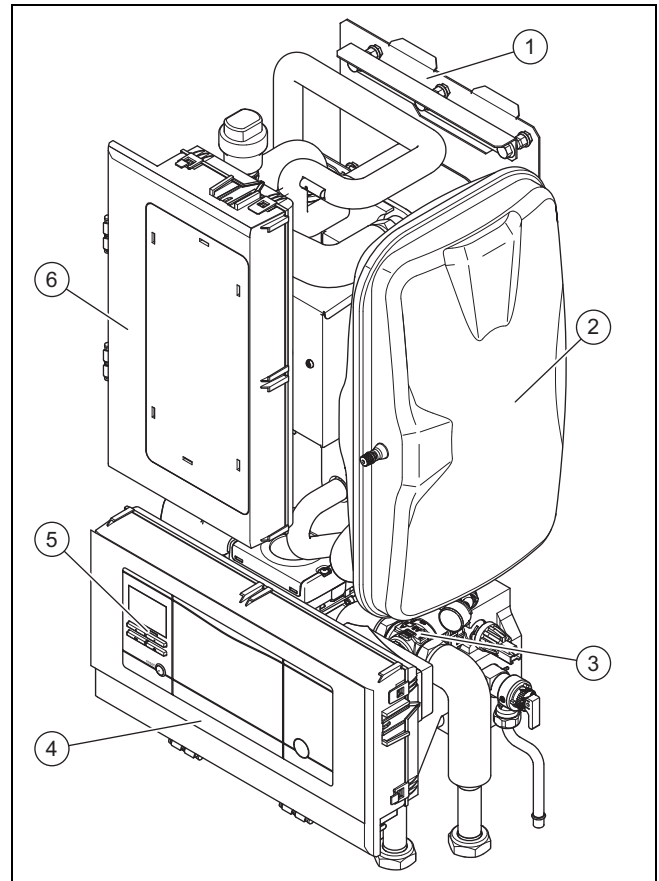

- | | | | |
|---|--------------------------|---|--|
| 1 | Unit mounting bracket | 5 | Indoor unit control |
| 2 | Expansion vessel | 6 | Electronics box (for back-up immersion heater) |
| 3 | Hydraulic block | | |
| 4 | Electronics box with PCB | | |

3.5.2 Design of the hydraulic block

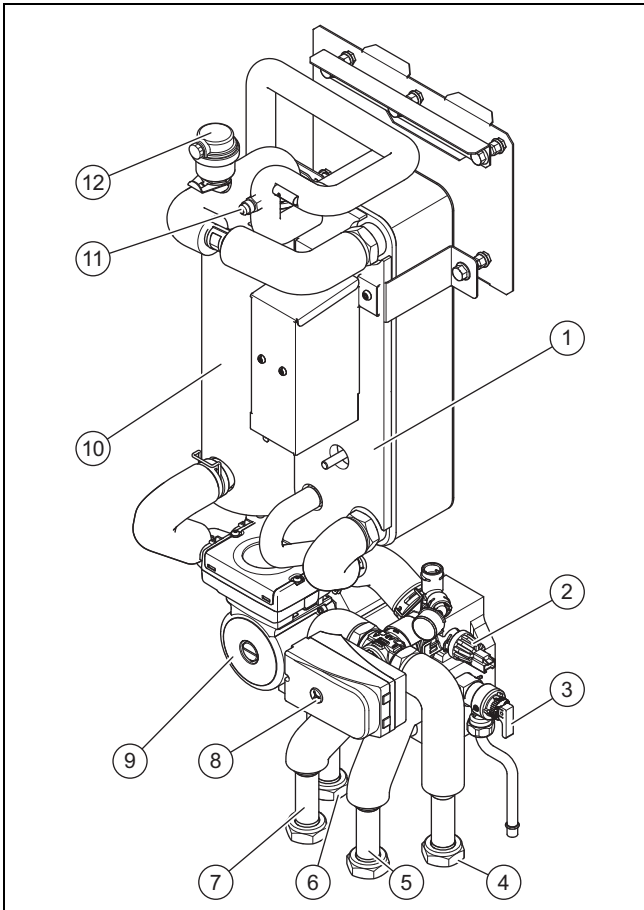

- | | | | |
|---|------------------------------------|----|--|
| 1 | Condenser | 8 | Prioritising diverter valve (heating circuit/cylinder charging) |
| 2 | Pressure sensor (heating circuit) | 9 | Heating pump |
| 3 | Expansion relief valve | 10 | Electric back-up heater |
| 4 | Heating return | 11 | Service valve for filling and creating a vacuum in the refrigerant circuit |
| 5 | Heating flow | 12 | Automatic air vent |
| 6 | Domestic hot water cylinder return | | |
| 7 | Domestic hot water cylinder flow | | |

3.5.3 Underside of the product

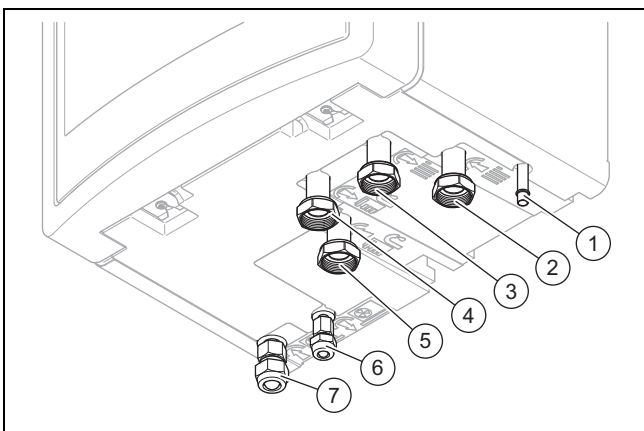

- | | | | |
|---|----------------------------------|---|------------------------------------|
| 1 | Drain for expansion relief valve | 5 | Domestic hot water cylinder return |
| 2 | Heating return | 6 | Liquid pipe connection |
| 3 | Heating flow | 7 | Hot gas pipe connection |
| 4 | Domestic hot water cylinder flow | | |

3.6 Service valve

At the service valve, you can test the vacuum, carry out pressure tests, and fill the refrigerant circuit.

- Tightening torque of the service valve's sealing cap: 4 Nm

3.7 Serial number

The serial number can be found on the data plate on the rear of the electronics box.







The serial number may also be shown on the product's display (→ Operating instructions).

3.8 Information on the data plate

The data plate is located on the rear of the electronics box.

	Information	Meaning
	Serial no.	Unique unit identification number
Nomenclature	VWL	Vaillant, heat pump, air
	5, 7, 12	Heating output in kW
	7	Heating mode or cooling mode
	/5	Unit generation
	IS	Indoor unit, split technology
	230 V	Electrical connection: 230 V: 1~/N/PE 230 V 400 V: 3~/N/PE 400 V
	IP	Protection class
Symbols		Compressor
		Control
		Refrigerant circuit
		Heating circuit
		Back-up heater
	P max	Rated power, maximum
	I max	Rated current, maximum
	I	In-rush current
Refrigerant circuit	MPa (bar)	Permissible operating pressure (relative)
	R410A	Refrigerant, type
	GWP	Refrigerant, global warming potential
Heating circuit	MPa (bar)	Permissible operating pressure
	CE marking	See section "CE marking"

3.9 Connection symbols

Symbol	Connection
	Building circuit, flow
	Building circuit, return
	Refrigerant circuit, hot gas pipe
	Refrigerant circuit, liquid pipe
	Domestic hot water cylinder, flow
	Domestic hot water cylinder, return

3.10 CE marking



The CE marking shows that the products comply with the basic requirements of the applicable directives as stated on the declaration of conformity.

The declaration of conformity can be viewed at the manufacturer's site.

3.11 Application limits

The product works between a minimum and maximum outdoor temperature. These outdoor temperatures define the application limits for the heating mode, domestic hot water mode and cooling mode. See Technical data (→ Appendix R). Operating outside of the application limits leads to the product switching off.

3.11.1 Heating mode

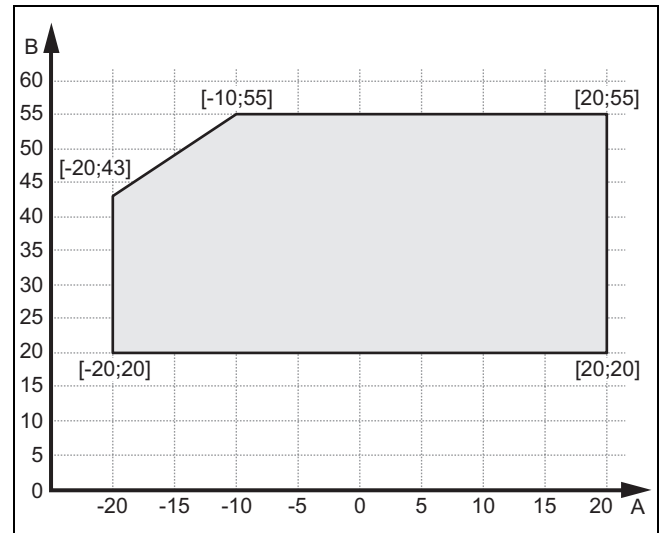

A Outdoor temperature B Heating water temperature

3.11.2 DHW mode

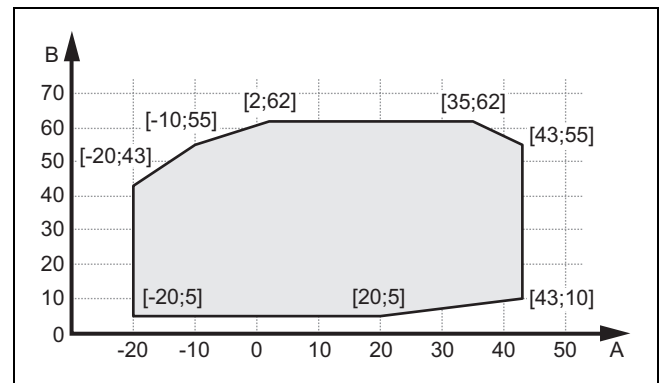

A Outdoor temperature B Heating water temperature

3.11.3 Cooling mode

Validity: Product with cooling mode

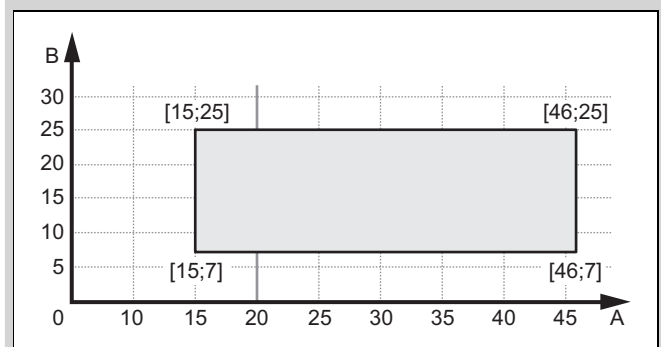

A Outdoor temperature B Heating water temperature

3.12 Buffer cylinder

Heating installations, which mainly consist of fan coils or radiators, usually contain a low volume of water. We recommend installing a buffer cylinder. In the case of two or more heating circuits in the system, a buffer cylinder or a low loss header should also be used as decoupling.

For the outdoor unit, it is important for the evaporator's de-icing process that sufficient thermal energy can be provided.

You can find information about designing a buffer cylinder in the associated installation instructions for the outdoor unit, which is used in combination with the current indoor unit.

3.13 Cooling mode

Depending on the country, the outdoor unit has the heating mode or heating and cooling mode function. The indoor unit is compatible with this.

Outdoor units that are delivered at the factory with no cooling mode are labelled with "S2" in the nomenclature. For these units, an optional accessory can be used to subsequently activate the cooling mode.

It is activated via a coding resistor and via a setting on the indoor unit's control panel and on the optional system control. (→ Section 8.19)

3.14 Display of the energy consumption, energy yields and efficiencies

The product, the system control and the app show approximate values for energy consumption, energy yields and efficiencies, which are extrapolated based on calculation algorithms.

The values that are displayed in the app may differ from the other display options due to staggered transfer intervals.

The determined values depend on:

- Installation and system of the heating installation
- User behaviour
- Seasonal weather effects
- Various tolerances of unit-internal components

The recording of the values only includes the product in the factory-delivered condition. Supplementary accessories, even if they are installed on the product, as well as any other components in the heating system and other external consumers, are not part of the data recording.

Deviations between the determined values and the actual values may be significant. The determined values are therefore not suitable for creating or comparing energy billing, for example.

When replacing the PCB, the values for energy consumption, energy yields and efficiencies are reset in the heat pump's control panel.

4 Set-up

4.1 Unpacking the product

1. Remove the product from the packaging.
2. Remove the documentation.
3. Remove the protective film from all parts of the product.

4.2 Checking the scope of delivery

- ▶ Check that the scope of delivery is complete and intact.

Number	Designation
1	Hydraulic station
1	Enclosed documentation
1	Bag with installation material
1	Selection lever for prioritising diverter valve
1	Filling device
1	5-pole 400 V connection cable
1	Adhesive strips for noise reduction

4.3 Selecting the installation site

- ▶ The installation site must be below 2000 metres above sea level.
- ▶ Select a dry room that is frost-proof throughout and in which the maximum installation height is not exceeded and the environmental temperature is neither above nor below the permitted range.
 - Permissible environmental temperature: 7 to 25 °C
 - Permissible relative air humidity: 40 to 75 %
- ▶ Ensure that the installation room has the required minimum volume.

Heat pump	R410A refrigerant filling volume	Minimum installation room volume
VWL 57/5 IS	1.5 kg	3.41 m ³
VWL 77/5 IS	2.4 kg	5.45 m ³
VWL 127/5 IS	3.6 kg	8.18 m ³
Minimum installation room = refrigerant filling volume (kg)/practical limit value (kg/m ³) (for R410A = 0.44 kg/m ³)		

- ▶ Ensure that the required minimum clearances can be maintained.
- ▶ Observe the permissible height difference between the outdoor unit and the indoor unit (→ Installation instructions for the outdoor unit).
- ▶ When selecting the installation site, you must take into consideration that when the heat pump is in operation, it will transfer vibrations to the walls.
- ▶ Ensure that the wall is even and offers sufficient load-bearing capacity to bear the weight of the product.
- ▶ Ensure that pipes can be easily routed in an appropriate way (domestic hot water side, heating side and refrigerant side).
- ▶ Do not install the product above another unit that may damage it (e.g. above a cooker that produces water vapour and grease) or in a room with a high level of exposure to dust or in a corrosive environment.
- ▶ Do not install the product below a unit from which liquids may flow.

4.4 Dimensions

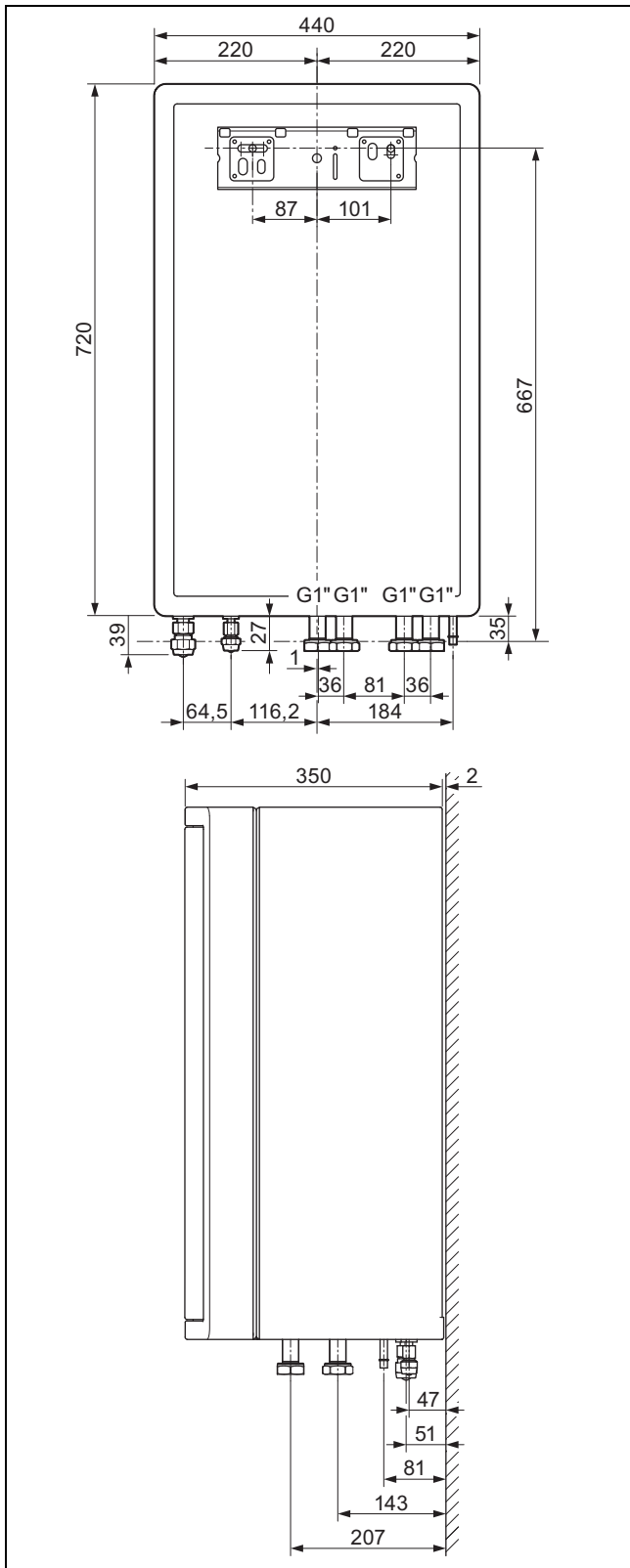

4.5 Minimum clearances and installation clearances

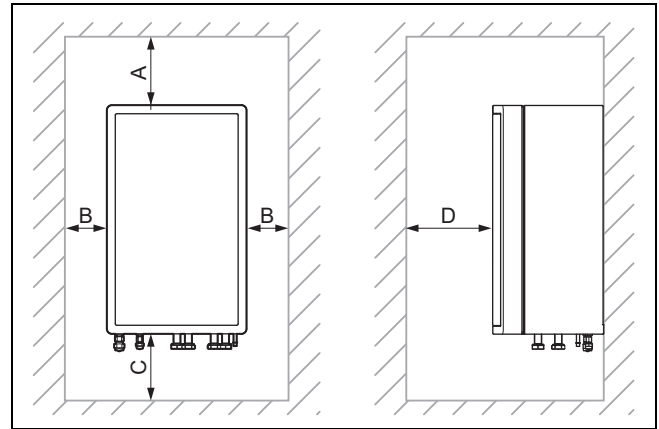

A	Min. 200 mm	C	1000 mm
B	Min. 200 mm	D	> 600 mm

- ▶ Provide sufficient clearance on both sides of the product in order to facilitate access for maintenance and repair work.
- ▶ When using the accessories, observe the minimum clearances/installation clearances.
- ▶ Ensure that no highly flammable parts come into contact with the components as these may reach temperatures of over 80°C.
- ▶ Ensure that there is a minimum clearance between the highly flammable parts and the hot components.
 - Minimum clearance: 200 mm

4.6 Wall-mounting the product

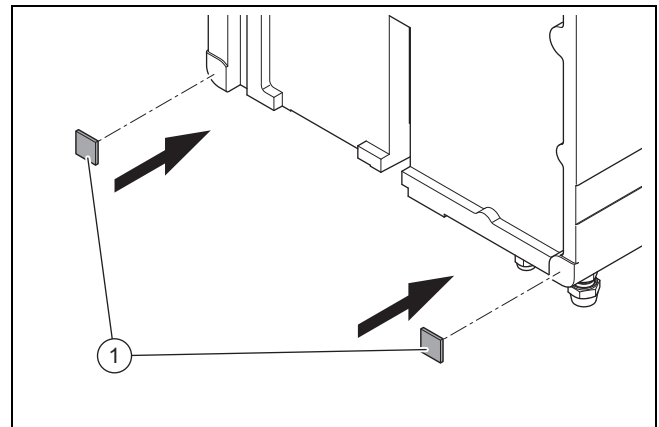

1. Cut the enclosed adhesive strips for noise reduction into two equally sized pieces (3 cm x 3 cm).
2. Affix the adhesive strips to the product as shown in the figure.

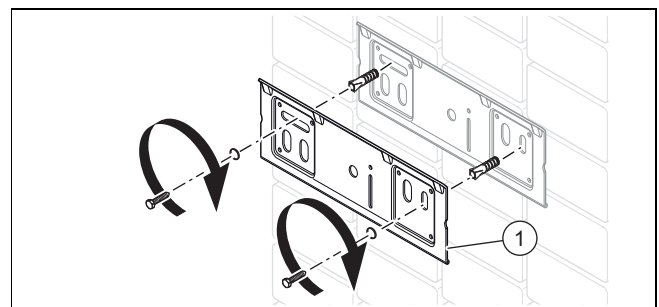

3. Check whether the wall has sufficient load-bearing capacity to bear the operating weight of the product.

4. Check if the supplied fixing material may be used for the wall.

Condition: The load-bearing capacity of the wall is sufficient, The fixing material is permitted for the wall

- ▶ Secure the unit mounting bracket to the wall as described in the figure.
- ▶ Suspend the product on the unit mounting bracket from above using the hanging bracket.

Condition: The load-bearing capacity of the wall is not sufficient

- ▶ Ensure that wall-mounting apparatus on-site has a sufficient load-bearing capacity. Use individual stands or primary walling, for example.
- ▶ Do not wall-mount the product if you cannot provide wall-mounting apparatus with a sufficient load-bearing capacity.

Condition: The fixing material is not permitted for the wall

- ▶ Wall-mount the product as described in the illustration using the permitted fixing material provided on-site.

4.7 Removing the front casing

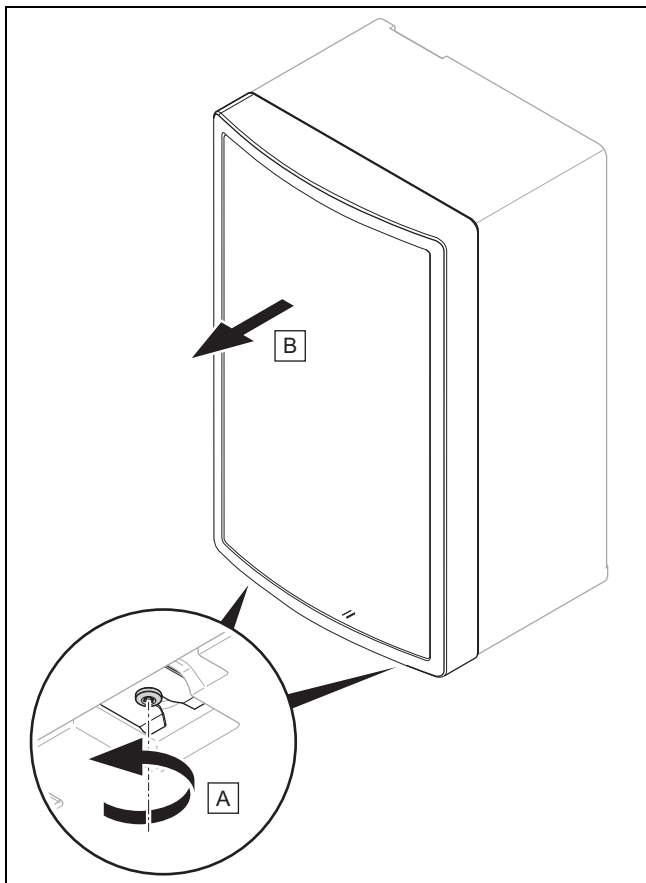

- ▶ Reinstall the components in the reverse order.

4.8 Removing the bottom casing

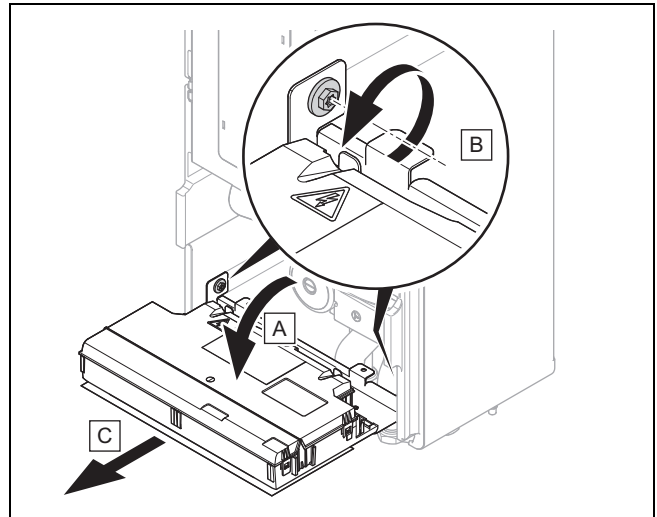

1. Hinge the electronics box forwards.
2. Open the electronics box and remove the top cover.
3. Remove the plug from the PCB.
4. Remove both screws as shown in the figure.
5. Pull out the electronics box towards the front.
6. Pull out the bottom casing towards the front.
7. Reinstall the components in the reverse order.

5 Hydraulics installation

5.1 Carrying out the installation preparations

- ▶ Install the following components, preferably from the manufacturer's accessories:
 - An expansion relief valve, a stopcock and a manometer on the heating return
 - A domestic hot water safety assembly and a stopcock on the cold water supply
 - A stopcock on the heating flow
- ▶ Check whether the volume of the installed expansion vessel is sufficient for the heating system. If the volume of the installed expansion vessel is insufficient, install an additional expansion vessel, connected as close to the product as possible, in the heating return. Adjust the pre-charge pressure of the heating installation.
- ▶ Install the connection pipes such that they are free from mechanical stress.
- ▶ Flush the heating installation through thoroughly before connecting the product in order to remove any residue which could be deposited in the product and lead to damage.
- ▶ Only solder connectors if the connectors are not yet screwed to the service valves.
- ▶ Check whether, when you open the catches on the refrigerant pipes, you can hear a hissing sound (caused by a factory-side excess pressure of nitrogen). If you do not find any excess pressure, check all of the screwed connections and pipes for leakages.
- ▶ Check whether the expansion relief valve's drain pipe-work opposite the outdoor air remains open, is installed in a frost-free environment, always runs downwards and visibly ends in an open drain.
- ▶ For heating installations with solenoid valves or thermostatically controlled valves, install a bypass with bypass valve in order to guarantee a volume flow of at least 40%.

5.2 Routing refrigerant pipes

1. Observe the information on handling refrigerant pipes in the installation instructions for the outdoor unit.
2. Route the refrigerant pipes from the wall duct to the product.
3. Bend the pipes only once into their final position. Use a bending spring or another suitable bending tool to avoid kinks.

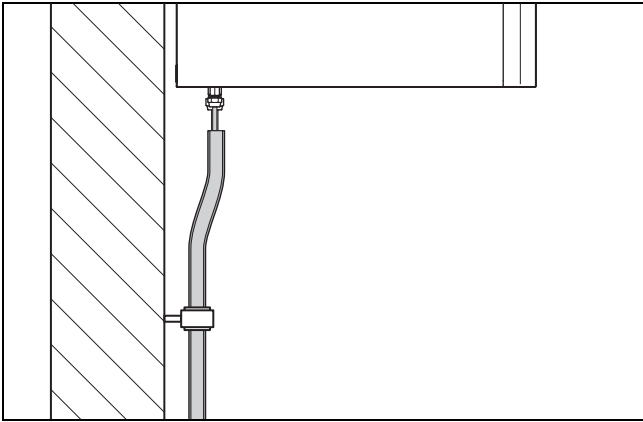

4. Secure the pipes to the wall using insulated wall brackets (cold insulation brackets).

5.3 Connecting the refrigerant pipes



Danger!

Risk of injury and risk of environmental damage due to escaping refrigerant.

Touching any escaping refrigerant may cause injury. Escaping refrigerant leads to environmental damage if it reaches the atmosphere.

- Only carry out work on the refrigerant circuit if you have been trained to do so.

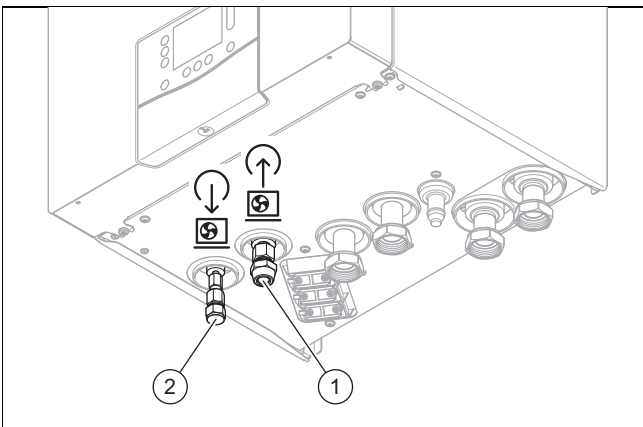

1. Remove the flare nuts and the catches from the connections for the refrigerant pipes on the product.
 - ◁ An audible hissing sound (escaping nitrogen) shows that the refrigerant circuit in the product is leak-tight.
2. Apply a drop of flare oil to the outsides of the pipe ends in order to prevent the flare edge from breaking away when tightening screwed connections.
3. Connect the hot gas pipe (2). Use the product's flare nuts.



Caution.

Risk of damage to the refrigerant pipes caused by excessive tightening torque

- Note that the following torques only refer to flared connections. The torques for SAE connections are lower.

4. Tighten the flare nut.

Heat output	Pipe diameter	Tightening torque
6 kW	1/2 "	50 to 60 Nm
8 to 12 kW	5/8 "	65 to 75 Nm

5. Connect the liquid pipe (1). Use the product's flare nuts.

6. Tighten the flare nut.

Heat output	Pipe diameter	Tightening torque
6 kW	1/4 "	15 to 20 Nm
8 to 12 kW	3/8 "	35 to 45 Nm

5.4 Checking the refrigerant pipes for tightness

1. Check the refrigerant pipes for tightness (see the installation instructions for the outdoor unit).
2. Ensure that the heat insulation of the refrigerant pipes is still sufficient after installation.

5.5 Installing the heating flow and heating return for the domestic hot water cylinder

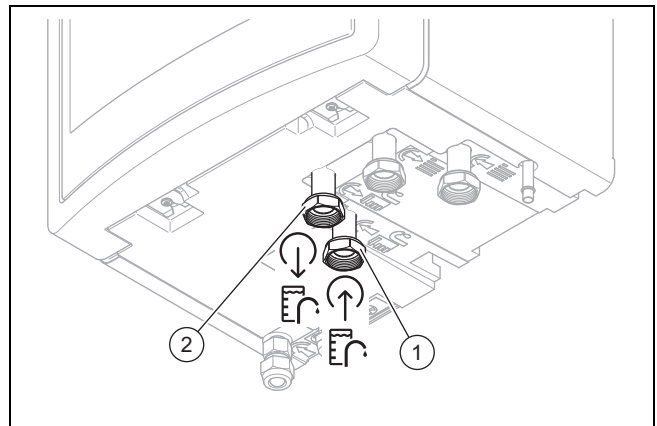

- Install the heating return (1) and the heating flow (2) for the domestic hot water cylinder in accordance with the relevant standards.

Connection symbols (→ Section 3.9)

5.6 Installing the building circuit connections

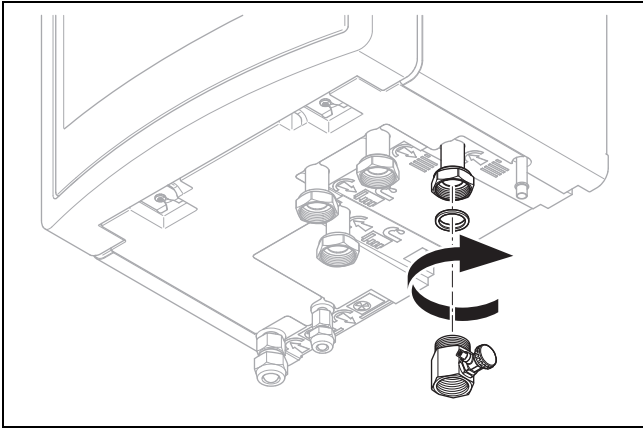

1. Install the filling device on the product's building circuit return using the seal provided.

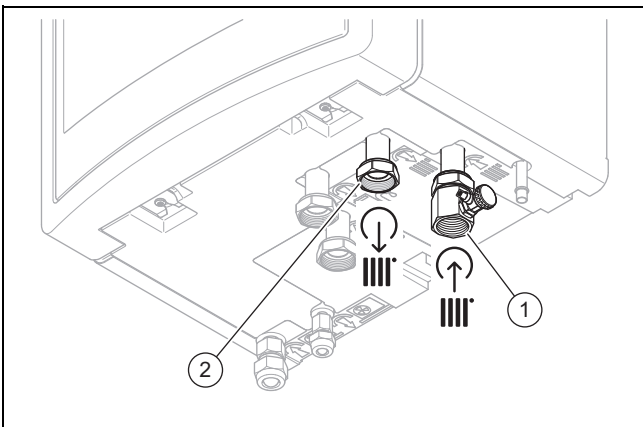

2. Install the building circuit's flow (1) and return (2) in accordance with the relevant standards.
Connection symbols (→ Section 3.9)

5.7 Installing a drain on the expansion relief valve

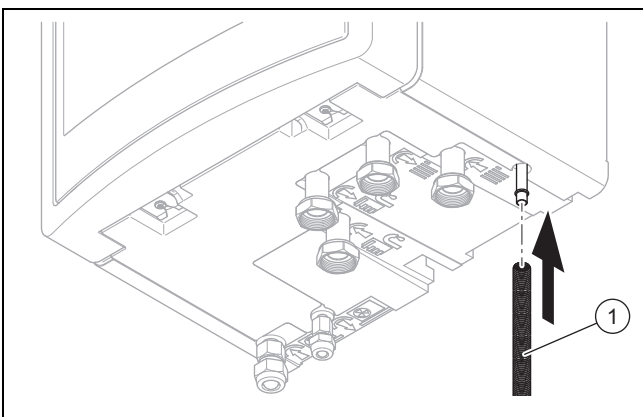

1. Install a drain hose (1) on the expansion relief valve.
2. Install the expansion relief valve hose in a frost-free environment and ensure that its routing ends in an open drain where it is then visible.
3. Ensure that escaping water does not endanger any people or electronic components.
4. Ensure that the drain hose is installed frost-proof and with a sufficient downward gradient.

6 Electrical installation

6.1 Preparing the electrical installation



Danger!

Risk of death from electric shock as a result of an improper electrical connection!

An improper electrical connection may negatively affect the operational safety of the product and result in material damage or personal injury.

- Only carry out the electrical installation if you are a trained competent person and are qualified for this work.

1. Observe the technical connection conditions for connecting to the energy supply company's low-voltage network.
2. Use the data plate to determine whether the product requires a 1~/230V or a 3~/400V electrical connection.
3. The product is pre-configured at the factory for the unblocked 1~/230V connection.
4. Determine whether the power supply for the product should be set up with a single-tariff meter or a dual-tariff meter.
5. Ensure that the nominal voltage of the single-phase network is 230 V (+10%/-15%) and the nominal voltage of the three-phase network is 400 V (+10-15%).
6. Connect the product using a fixed connection and a partition with a contact gap of at least 3 mm (e.g. fuses or power switches).
7. Use the data plate to determine the product's rated current. Derive the suitable cable cross-sections for the electrical wires from this. The requirements for the cables can be found in from (→ Section 6.7.1) to (→ Section 6.8.2).
8. In each case, take into consideration the (on-site) installation conditions.
9. Ensure that the nominal voltage of the power grid corresponds to that of the product's main power supply cabling.
10. Make sure that access to the power supply is always available and is not covered or blocked.
11. If the local power supply network operator requires that the heat pump is controlled using a blocking signal, install a corresponding contact switch as prescribed by the power supply network operator.

6.2 Requirements for the quality of the mains voltage

For the mains voltage of the single-phase 230 V network, a tolerance of +10% to -15% must be provided.

For the mains voltage of the three-phase 400 V network, a tolerance of +10% to -15% must be provided. For the voltage difference between the individual phases, a tolerance of +/-2% must be provided.

6.3 Electrical partition

The electrical partitions are referred to as "disconnectors" in these instructions. The fuse or the circuit breaker that is installed in the building's meter/fuse box is usually used as the disconnector.

6.4 Installing components for the energy supply company lockout function

Condition: Energy supply company lockout function provided

The heat generation of the heat pump can be switched off intermittently. It is switched off by the energy supply company and usually with a ripple control receiver.

Option 1: Actuating connection S21

- ▶ Connect a 2-pole control cable to the relay contact (potential-free) for the ripple control receiver and to the connection S21, see appendix.



Note

In the event of control via connection S21, the energy supply does not have to be disconnected on-site.

- ▶ In the system control, set whether the back-up heater, the compressor or both should be blocked.
- ▶ Set the parametrisation for connection S21 in the system control.

Option 2: Disconnect the power supply with contactor

- ▶ Upstream of the indoor unit, install a contactor into the power supply for the low tariff.
- ▶ Install a 2-pole control cable. Connect the control output for the ripple control receiver to the control input for the contactor.
- ▶ Undo the lines to plug X311, which were factory-installed, and remove these along with plug X310.
- ▶ Connect an unblocked power supply to X311.
- ▶ Connect the power supply that is switched by the contactor to X300, see appendix.



Note

When the energy supply (for the compressor or back-up heater) is switched off via the tariff contactor, S21 is not connected.

6.5 Opening the power supply PCB's electronics box

1. Remove the front casing. (→ Section 4.7)

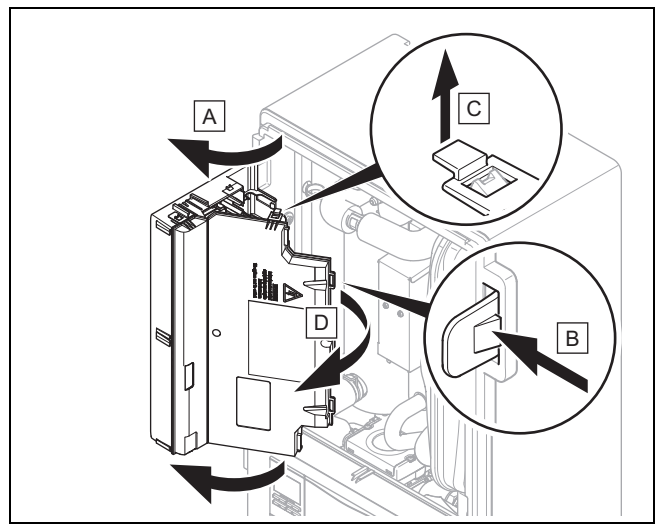

2. Hinge the electronics box forwards.
3. Detach the four clips, on the left and the right, from the brackets.

6.6 Routing the cables in the product

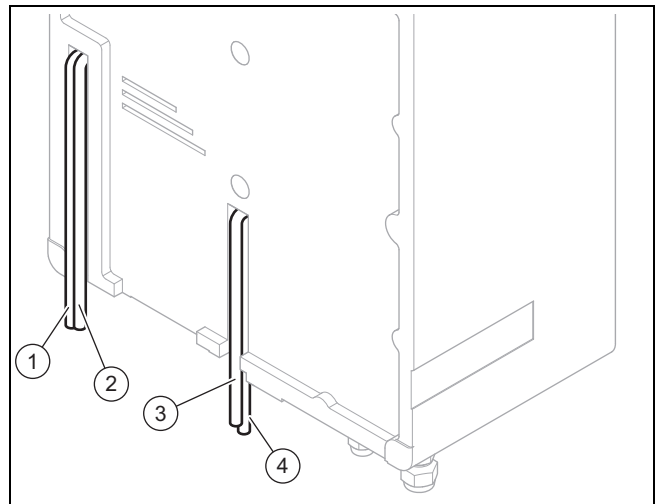

1. Remove the front casing. (→ Section 4.7)
2. Open the power supply PCB's electronics box. (→ Section 6.5)
3. Guide the power supply cable (3) and other power supply cables (230 V) (4) through the central unit opening and into the product.
4. Guide the eBUS cable (1) and other low-voltage connection cables (24 V) (2) through the left-hand unit opening and into the product.

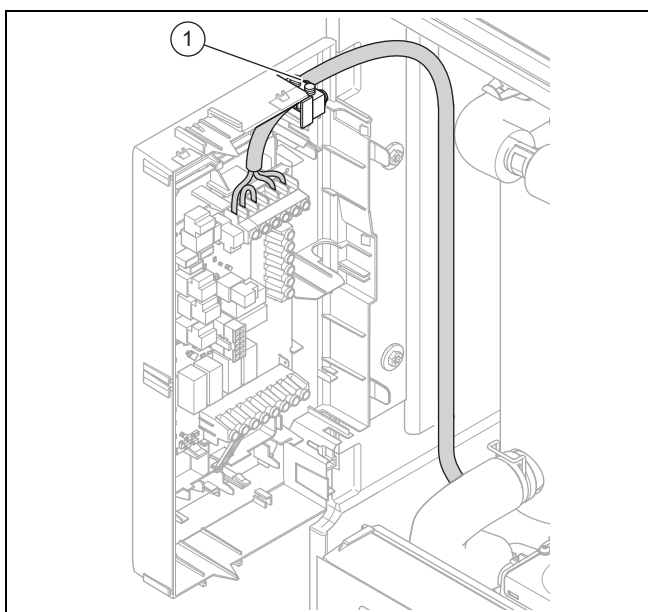

5. Guide the power supply cables through the strain relief (1) to the terminals on the power supply PCB.
6. Connect the power supply cable to the corresponding terminals.
7. Secure the power supply cable in the strain reliefs.

6.7 Establishing the power supply, 1~/230V

- Determine the type of connection:

Case	Connection type
Energy supply company lockout not provided	Single power supply
Energy supply company lockout provided, shutdown via connection S21	
Energy supply company lockout provided, shutdown via partition	Dual power supply

6.7.1 1~/230V single power supply



Caution.
Risk of material damage due to high connected voltage.

With excessive mains voltages, electronic components may be damaged.

- Ensure that the mains voltage is in the permissible range.

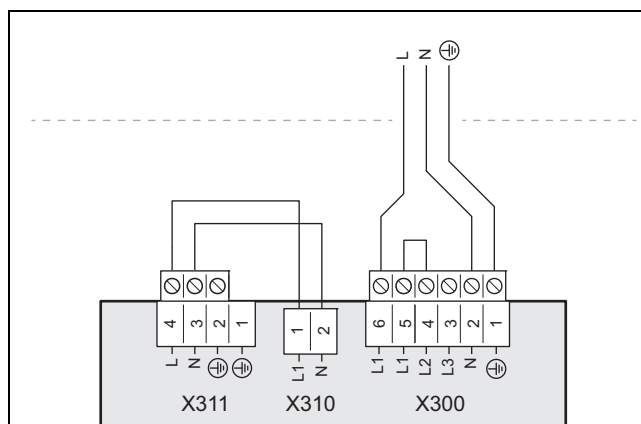

1. Install a separate type B residual-current circuit breaker for the product.
2. Note the specifications on the sticker on the electronics box.
3. Use a 3-pole power supply cable with a conductor cross-section of 4 mm² and a temperature resistance of 90 °C.
 - When using a different cable for the fixed connection than the one included in the scope of delivery, note that commercially available power supply cables do not usually have sufficient temperature resistance.
4. Remove the cable jacket until there is only 30 mm left.
5. Connect the power supply cable to L1, N, PE, as shown.
6. Use the strain relief clamp to secure the cable in place.
7. Observe the instructions on connecting a dual-tariff supply; see (→ Section 6.4).

6.7.2 1~/230V dual power supply



Caution.
Risk of material damage due to high connected voltage.

With excessive mains voltages, electronic components may be damaged.

- Ensure that the mains voltage is in the permissible range.

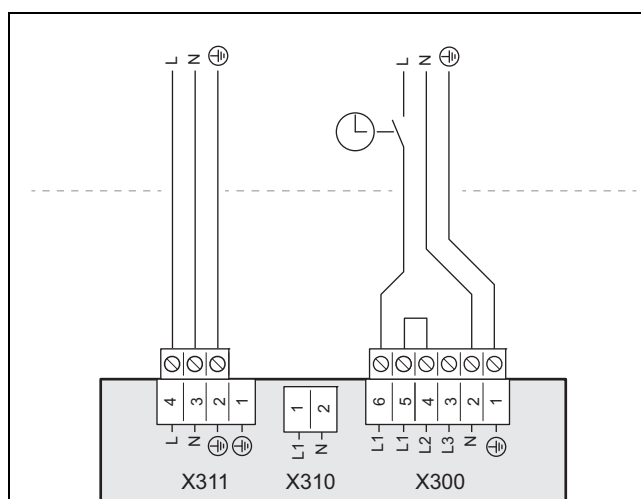

1. Install a separate type B residual-current circuit breaker for the product.
2. Note the specifications on the sticker on the electronics box.

3. Use a 3-pole power supply cable (low tariff) with a conductor cross-section of 4 mm^2 and a temperature resistance of $90 \text{ }^\circ\text{C}$. Use a 3-pole power supply cable (high tariff) with a conductor cross-section of 0.75 mm^2 and a temperature resistance of $90 \text{ }^\circ\text{C}$.
 - When using a different cable for the fixed connection than the one included in the scope of delivery, note that commercially available power supply cables do not usually have sufficient temperature resistance.
4. Remove the cable jacket until there is only 30 mm left.
5. Connect the power supply cable, as shown.
6. Use the strain relief clamp to secure the cable in place.
7. Observe the instructions on connecting a dual-tariff supply; see (→ Section 6.4).

6.8 Establishing the power supply, 3~/400V

- ▶ Determine the type of connection:

Case	Connection type
Energy supply company lockout not provided	Single power supply
Energy supply company lockout provided, shutdown via connection S21	
Energy supply company lockout provided, shutdown via partition	Dual power supply

6.8.1 3~/400V single power supply



Caution.
Risk of material damage due to high connected voltage.

With excessive mains voltages, electronic components may be damaged.

- ▶ Ensure that the mains voltage is in the permissible range.

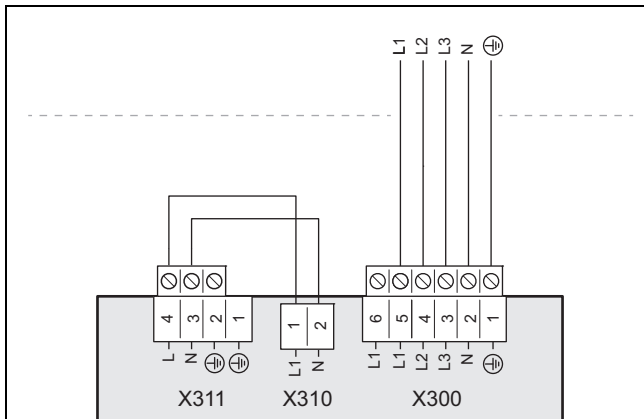

1. Install a separate type B residual-current circuit breaker for the product.
2. Note the specifications on the sticker on the electronics box.
3. Use a 5-pole power supply cable with a conductor cross-section of 2.5 mm^2 and a temperature resistance of $90 \text{ }^\circ\text{C}$.

- When using a different cable for the fixed connection than the one included in the scope of delivery, note that commercially available power supply cables do not usually have sufficient temperature resistance.
4. Remove the cable jacket until there is only 70 mm left.
 5. Remove the jumper from between connections L1 and L2.
 6. Connect the power supply cable to L1, L2, L3, N, PE, as shown.
 7. Observe the instructions on connecting a dual-tariff supply; see (→ Section 6.4).

6.8.2 3~/400V dual power supply



Caution.
Risk of material damage due to high connected voltage.

With excessive mains voltages, electronic components may be damaged.

- ▶ Ensure that the mains voltage is in the permissible range.

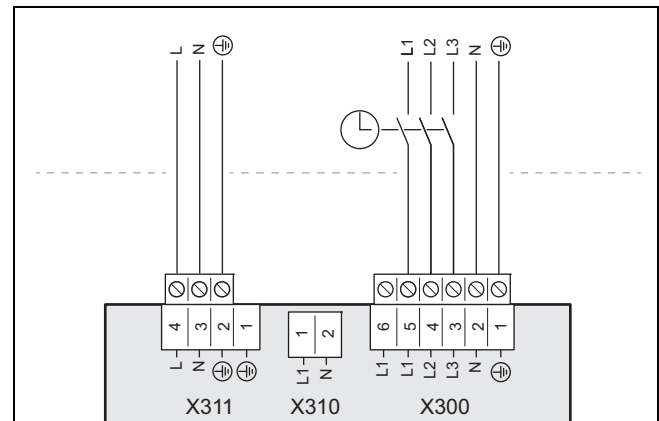

1. Install a separate type B residual-current circuit breaker for the product.
2. Note the specifications on the sticker on the electronics box.
3. Use a 5-pole power supply cable (low tariff) with a conductor cross-section of 2.5 mm^2 and a temperature resistance of $90 \text{ }^\circ\text{C}$. Use a 3-pole power supply cable (high tariff) with a conductor cross-section of 0.75 mm^2 and a temperature resistance of $90 \text{ }^\circ\text{C}$.
 - Note that commercially available power supply cables do not usually have sufficient temperature resistance. When using a different cable for the fixed connection than the one included in the scope of delivery, note that commercially available power supply cables do not usually have sufficient temperature resistance.
4. Remove the cable jacket until there is only 70 mm left for the 5-pole cable, and only 30 mm left for the 3-pole cable.
5. Remove the jumper from between connections L1 and L2.
6. Connect the power supply cable, as shown.
7. Observe the instructions on connecting a dual-tariff supply; see (→ Section 6.4).

6.9 Limiting the power consumption

The electrical power for the back-up heater on the product and the compressor for the outdoor unit can be limited. You can set the maximum output in the product's display.

6.10 Installing the system control in the electronics box

Condition: Installing a multiMATIC VRC 700

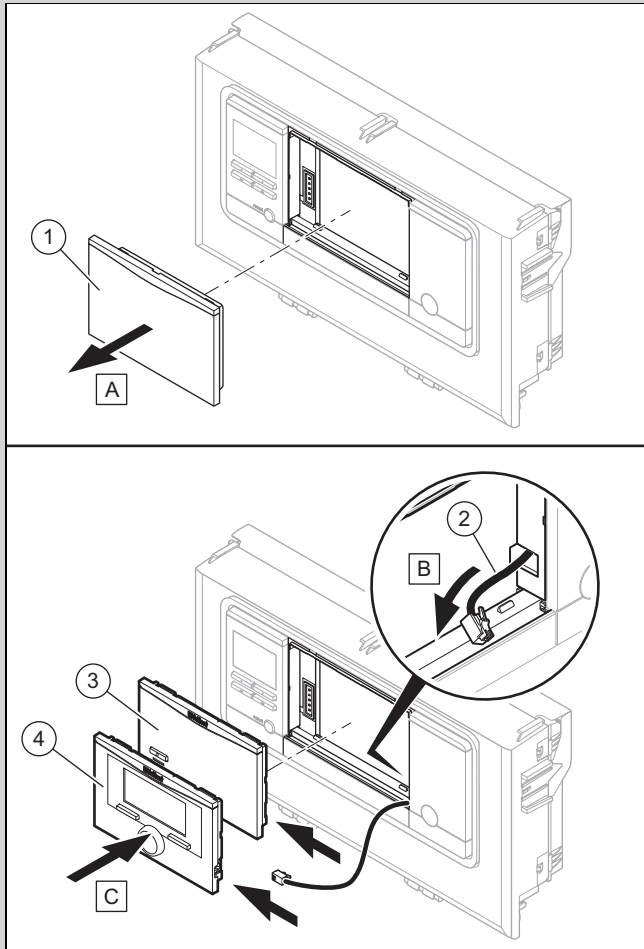

- ▶ Remove the cover (1) on the electronics box.
- ▶ Connect the DIF cable (2), which is laid out ready, either to the system control or to the mobile base station.
- ▶ If you are using a radio receiver, use the mobile base station (3).
- ▶ Consult the instructions for the system control for information on coupling the mobile base station and the system control.
- ▶ If you are using the wired system control, use the system control (4), → Installation instructions for the system control and system instructions.
- ▶ Consult the wiring diagram in the appendix for information on the integration into the eBUS network.

6.11 Requirements for the eBUS line

Observe the following rules when routing the eBUS lines:

- ▶ Use twin-core cables.
- ▶ Never use shielded or twisted cables.
- ▶ Use only appropriate cables, e.g. NYM or H05VV (-F/-U).
- ▶ Observe the permissible total length of 125 m. For a total length of up to 50 m, a conductor cross-section of $\geq 0.75 \text{ mm}^2$ applies; from 50 m upwards, a conductor cross-section of 1.5 mm^2 applies.

In order to prevent faults in the eBUS signals (e.g. due to interferences):

- ▶ Maintain a minimum clearance of 120 mm to power supply cables or other electromagnetic sources of interference.
- ▶ For parallel routing to mains connection lines, guide the cables in accordance with the applicable regulations, e.g. on cable trays.
- ▶ **Exceptions:** For wall breaks and in the electronics box, it is acceptable to not reach the minimum clearance.

6.12 Opening the control PCB's electronics box

1. Remove the front casing. (→ Section 4.7)

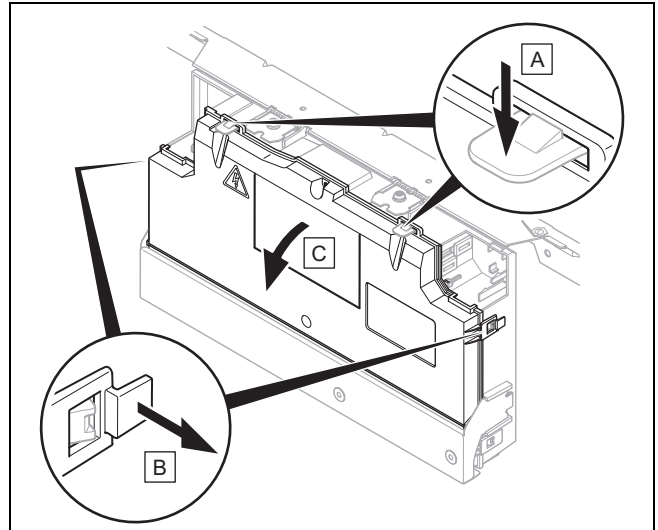

2. Hinge the electronics box (1) forwards.
3. Detach the four clips (3), on the left and the right, from the brackets.

6.13 Routing the cables in the electronics box

1. At lengths of over 10 m, route connection cables with mains voltage separately from sensor lines. Minimum clearance for the extra low-voltage wire and power supply cable at a line length of > 10 m: 25 cm.
2. Observe the requirements for eBUS lines. (→ Section 6.11)

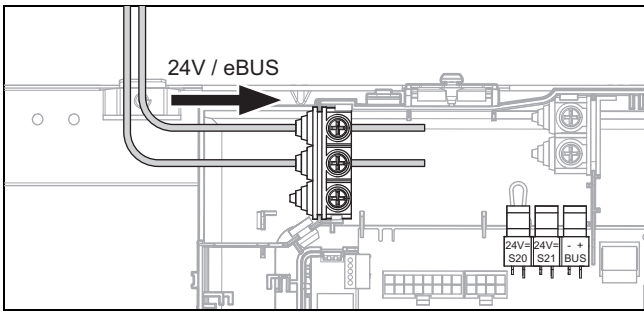

- Route 24 V cables and eBUS cables through the left-hand strain reliefs on the electronics box.

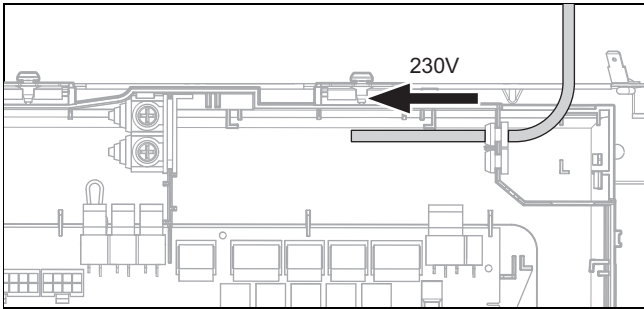

- Route 230 V cables through the right-hand strain reliefs on the electronics box.

6.14 Carrying out the wiring



Note

There is a safety extra-low voltage (SELV) at connections S20 and S21.



Note

If the energy supply company lockout function is used, connect a potential-free normally open contact with a breaking capacity of 24 V/0.1 A to connection S21. You must configure how the connection works in the system control. (For example, if the contact is closed, the electric back-up heater is blocked.)

- Ensure that the mains voltage is correctly disconnected from the safety extra-low voltage.
- Only connect power supply cables to the terminals that are marked for the purpose.
- Shorten the connection cables according to requirements.

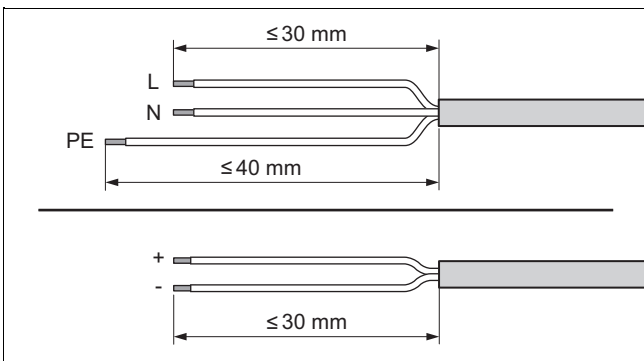

- Strip the electrical wire as shown in the figure. In doing so, ensure that the insulation on the individual conductors is not damaged.
- Ensure the inner conductor insulation is not damaged when stripping the outer sheathing.

- Only strip inner conductors just enough to establish good, sound connections.
- Fit conductor end sleeves on the stripped ends of the conductors.
- Screw the respective plug to the connection cable.
- Check whether all conductors are inserted mechanically securely in the plug terminals. Remedy this if necessary.
- Plug the plug into the associated PCB slot.

6.15 Connecting the circulation pump

- Route the 230 V connection cable for the circulation pump from the right and into the control PCB's electronics box.
- Connect the 230 V connection cable to the plug from slot X11 on the control PCB and plug it into the slot.

Condition: Activation of the circulation via an external button

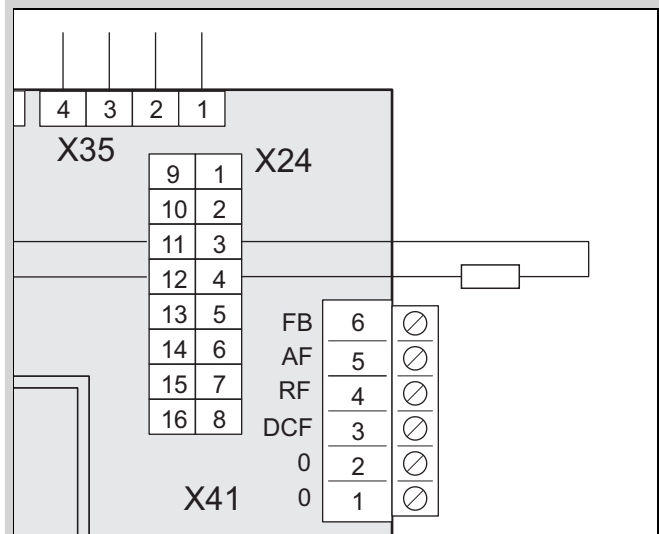

- Connect the connection cable for the external button using terminals 1 (0) and 6 (FB) on the X41 edge connector, which is supplied with the control.
- Plug the edge connector into slot X41 on the control PCB.

- Set the circulation pump in the system control.

6.16 Connecting a limit thermostat for the underfloor heating

- Route the connection cable for the limit thermostat through the left-hand strain reliefs on the electronics box.
- Pull out the S20 plug for the bypass line at terminal X100 on the control PCB.
- Connect the limit thermostat to plug S20.

6.17 Actuating a circulation pump with an eBUS control

1. Ensure that the circulation pump is correctly parametrised in the system control.
2. Select a hot water programme (preparation).
3. Parametrise a circulation programme in the system control.
 - ◀ The pump runs during the time period specified in the programme.

6.18 Connecting the domestic hot water cylinder

1. Connect the temperature sensor (VR 10) for the domestic hot water cylinder to the corresponding connection for wiring harness X22 on the control PCB. The range of accessories includes a temperature sensor (VR 10) with corresponding mating connector and an extension with corresponding plug and bush.
2. If an external current anode is installed in the domestic hot water cylinder, connect it to X313 or X314 on the power supply PCB.
 - ◀ The connection plug is included in the bag of small parts.

6.19 Connecting the external prioritising diverter valve (optional)

- ▶ Connect the external prioritising diverter valve to X14 on the control PCB.
 - The connection to a permanently live phase "L" with 230 V and to a switched phase "S" is available. Phase "S" is actuated by an internal relay and releases 230 V.

6.20 Connecting the outdoor temperature sensor

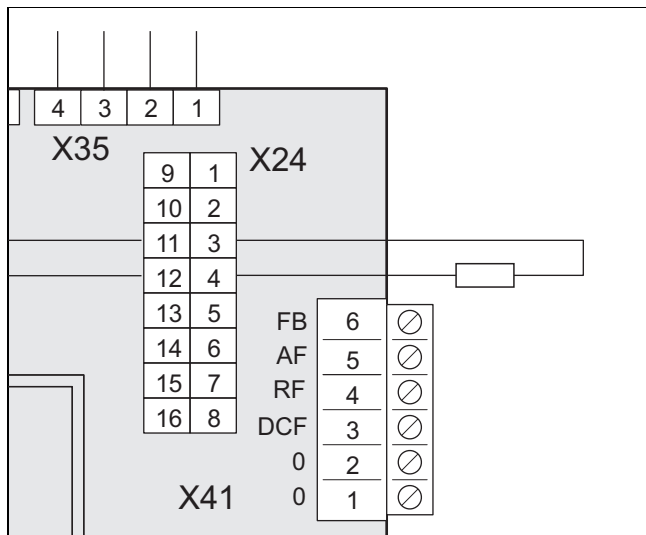

- ▶ Connect the connection cable for an outdoor temperature sensor to terminals 2 (0) and 5 (AF) on the X41 edge connector, which is supplied with the control. If a system control is present, also connect terminal 3 (DCF) of the edge connector.

6.21 Connecting the VR 70/VR 71 wiring centre

1. Connect the power supply for the VR 70/VR 71 wiring centre to X314 on the power supply PCB.
2. Connect the VR 70/VR 71 wiring centre to the eBUS interface on the control PCB.

6.22 Connecting cascades

- ▶ If you want to use cascades (max. seven units), you must connect the eBUS line to contact X100 via the VR32b bus coupler (accessory).

6.23 Closing the electronics box for the power supply PCB

1. Tighten all of the screws on the strain relief clamps.
2. Close the cover for the electronics box on the power supply PCB.
3. Hinge the electronics box back up.

6.24 Checking the electrical installation

- ▶ After the installation is complete, check the electrical installation to ensure that the connections that have been established are secured properly and are sufficiently insulated.

7 Operation

7.1 Operating concept of the product

The operating concept and the read-out and setting options of the end user level are described in the operating instructions.

8 Start-up

8.1 Setting the prioritising diverter valve

1. Install the selection lever from the bag of small parts on the prioritising diverter valve.

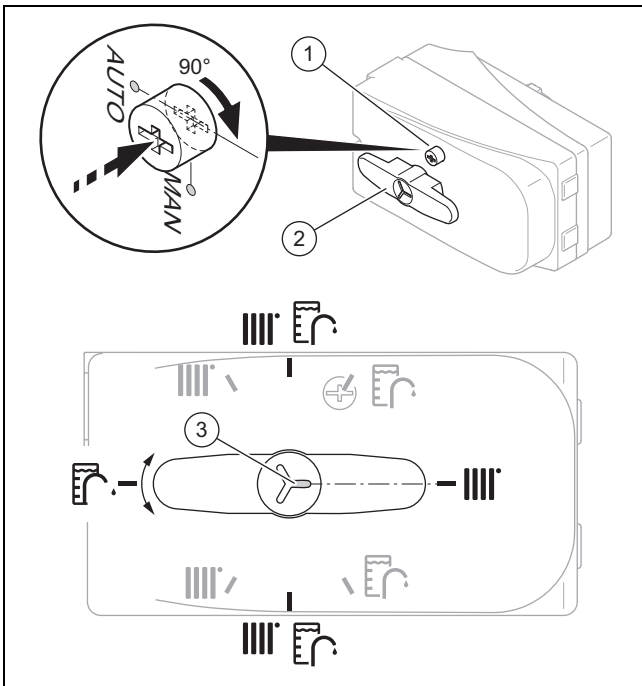

2. If you want to manually set the prioritising diverter valve, press the knob (1) and turn it 90° clockwise.
 - ◁ You can now turn the selection lever (2) to the required position.



Note

The notch (3) along the selection lever displays the selected mode; for example: If the notch along the selection lever is pointing clockwise: The heating circuit is selected. In automatic mode, the selection lever can move to other intermediate positions (grey).

3. If you want to actuate the heating circuit, turn the selection lever to "Heating circuit".
4. If you want to actuate the domestic hot water cylinder, turn the selection lever to "Domestic hot water cylinder".
5. If you want to actuate the heating circuit and the domestic hot water cylinder, turn the selection lever to "Heating circuit/domestic hot water cylinder".

8.2 Checking and treating the heating water/filling and supplementary water



Caution.

Risk of material damage due to poor-quality heating water

- ▶ Ensure that the heating water is of sufficient quality.

- ▶ Before filling or topping up the installation, check the quality of the heating water.

Checking the quality of the heating water

- ▶ Remove a little water from the heating circuit.
- ▶ Check the appearance of the heating water.
- ▶ If you ascertain that it contains sedimentary materials, you must desludge the installation.
- ▶ Use a magnetic rod to check whether it contains magnetite (iron oxide).

- ▶ If you ascertain that it contains magnetite, clean the installation and apply suitable corrosion-inhibition measures (e.g. fit a magnetite separator).
- ▶ Check the pH value of the removed water at 25 °C.
- ▶ If the value is below 8.2 or above 10.0, clean the installation and treat the heating water.
- ▶ Ensure that oxygen cannot get into the heating water.

Checking the filling and supplementary water

- ▶ Before filling the installation, measure the hardness of the filling and supplementary water.

Treating the filling and supplementary water

- ▶ Observe all applicable national regulations and technical rules when treating the filling and supplementary water.

Provided the national regulations and technical rules do not stipulate more stringent requirements, the following applies:

You must treat the filling and supplementary water in the following cases

- If the entire filling and supplementary water quantity during the operating life of the system exceeds three times the nominal volume of the heating installation, or
- If the guideline values listed in the following table are not met, or
- If the pH value of the heating water is less than 8.2 or more than 10.0.

Total heating output	Water hardness at specific system volume ¹⁾					
	≤ 20 l/kW		> 20 l/kW ≤ 40 l/kW		> 40 l/kW	
kW	ppm CaCO ₃	mol/m ³	ppm CaCO ₃	mol/m ³	ppm CaCO ₃	mol/m ³
< 50	< 300	< 3	150	≤ 1.5	5	0.05
> 50 to ≤ 200	200	< 2	150	≤ 1.5	5	0.05
> 200 to ≤ 600	150	< 1.5	5	0.05	5	0.05
> 600	5	0.05	5	0.05	5	0.05

1) Nominal capacity in litres/heat output; in the case of multi-boiler systems, the smallest single heat output is to be used.



Caution.

Risk of material damage if the heating water is treated with unsuitable additives.

Unsuitable additives may cause changes in the components, noises in heating mode and possibly subsequent damage.

- ▶ Do not use any unsuitable antifreeze and corrosion inhibitors, biocides or sealants.

No incompatibility with our products has been detected to date with proper use of the following additives.

- ▶ When using additives, follow the manufacturer's instructions without exception.

We accept no liability for the compatibility of any additive or its effectiveness in the rest of the heating system.

Additives for cleaning measures (subsequent flushing required)

- Adey MC3+
- Adey MC5

- Fernox F3
- Sentinel X 300
- Sentinel X 400

Additives intended to remain permanently in the installation

- Adey MC1+
- Fernox F1
- Fernox F2
- Sentinel X 100
- Sentinel X 200

Additives for frost protection intended to remain permanently in the installation

- Adey MC ZERO
- Fernox Antifreeze Alpha 11
- Sentinel X 500

- ▶ If you have used the above-mentioned additives, inform the end user about the measures that are required.
- ▶ Inform the end user about the measures required for frost protection.

8.3 Filling and purging the heating installation

1. Flush the heating installation thoroughly prior to filling.
2. Open all of the thermostatic valves on the heating installation and, if required, all other isolation valves.
3. If no domestic hot water cylinder is connected, seal the product's cylinder flow and cylinder return connection with on-site plugs.
4. Check all of the connections and the entire heating installation for leaks.
5. Switch the prioritising diverter valve to manual operation (→ Section 8.1) and turn the selection lever to "Heating circuit/domestic hot water cylinder".
 - ◁ Both valves are open and the filling procedure is improved since the air in the system can escape.
 - ◁ The heating circuit and the spiral immersion heater for the domestic hot water cylinder are filled at the same time.

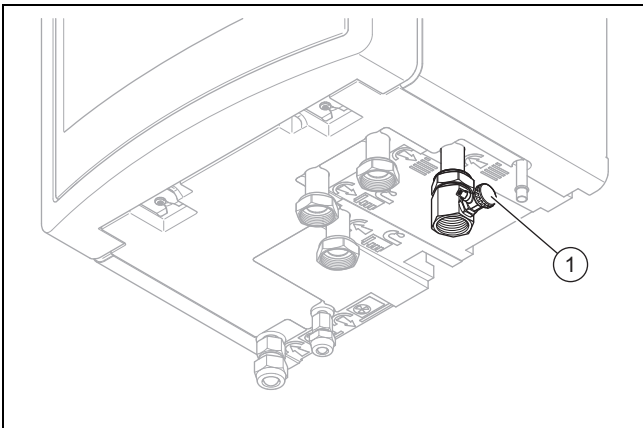

6. Connect a filling hose to the filling device (1).
7. To do this, unscrew the screw cap from the filling device and secure the free end of the filling hose to here.

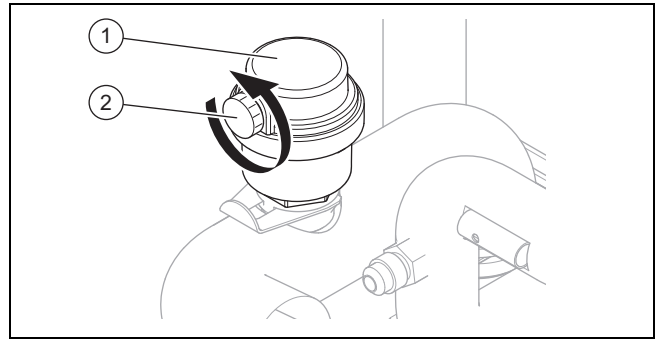

8. Open the purging screw (2) on the automatic air vent (1) in order to purge the product.
9. Open the filling device.
10. Open the heating water supply slowly.
11. Purge the highest radiator or underfloor heating circuit and wait until the circuit is completely purged.
 - ◁ The water must escape from the purging valve without bubbles.
12. Fill with water until the manometer (on-site) shows that the heating installation has reached a pressure of approx. 1.5 bar.



Note

If you fill the heating circuit at an external location, you must install an additional manometer to check the pressure in the installation.

13. Close the filling device.
14. Then check the heating installation pressure again (if required, repeat the filling procedure).
15. Remove the filling hose from the filling device and screw the screw cap back on.
16. Set automatic mode for the prioritising diverter valve again (→ Section 8.1).
 - ◁ When the product starts up, the diverter valve automatically moves to the "Heating circuit" outlet position.

8.4 Purging

1. Open the automatic air vent.
2. Start the purge programme for the building circuit P06 via: **Menu → Installer level → Test menu → Check programmes → Purge building circuit → P06.**
3. Allow the P06 function to run for 15 minutes.
 - ◁ The programme runs for 15 minutes. For 7.5 minutes of that time, the prioritising diverter valve is at the "heating circuit" position. The prioritising diverter valve then switches to the "domestic hot water cylinder" position for 7.5 minutes.
4. Once both purge programmes have finished, check whether the pressure in the heating circuit is 1.5 bar.
 - ◁ Top up with water if the pressure is below 1.5 bar.

8.5 Switching on the product



Note

The product does not have an on/off switch. The product is switched on as soon as it is connected to the power grid.

1. Use the partition that is installed on-site (e.g. fuses or power switches) to switch on the product.
 - ◁ The display shows the basic display.
 - ◁ The basic display appears on the system control display.
 - ◁ The system's products start up.
 - ◁ The heating and domestic hot water demand are activated by default.
2. When you start up the heat pump system for the first time after electrical installation, the installation assistants for the system components will start automatically. Set the required values on the control panel of the indoor unit first, then on the optional system control and the other system components.

8.6 Running the installation assistants

The installation assistant is launched when the product is switched on for the first time. It provides direct access to the most important check programmes and configuration settings for starting up the product.

Menu → Installer level → Configuration.

Confirm the launch of the installation assistant. All heating and domestic hot water demands are blocked whilst the installation assistant is active.

Set the following parameters:

- Language
- System control present
- Immersion heater power supply (electric back-up heater)
- Immersion heater power limit (electric back-up heater)
- Cooling technology
- Compressor current limit
- Relay multi-function output
- Check programme: Purge building circuit
- Contact details, Telephone number

To access the next item, confirm by pressing **Next** in each case.

If you do not confirm the launch of the installation assistant, it is closed 10 seconds after you switch on the unit and the basic display then appears. If the installation assistant does not run through completely, it restarts the next time the unit is switched on.

8.6.1 Ending the installation assistant

1. Once you have run through the installation assistant successfully, confirm by pressing 
 - ◁ The installation assistant will close and will not launch again when the product is next switched on.
2. Observe the corresponding sections and information in the system instructions.

8.7 Menu functions without the optional system control

If no system control is installed and this has been confirmed in the installation assistant, the following additional functions are displayed in the indoor unit's control panel:

- End user level
 - **Room temperature setpoint**
 - **Screed drying activ.**
 - **Target cylinder temp.**
 - **Domestic hot water cylinder temp.**
 - **Manual cooling activation**
- Installer level
 - **Heat curve**
 - **Summer sw.-off temp.**
 - **Heating biv. point**
 - **DHW bivalence point**
 - **Heating alt. point**
 - **Max. flow temperature**
 - **Min. flow temperature**
 - **Heating mode activ.**
 - **DHW activation**
 - **Cyl. charg. hysteresis**
 - **Limp home mode Immersion heater: Heating/DHW**
 - **Cooling target flow**
 - **Screed drying day**

The system control can only be retroactively deactivated to use the additional functions in the indoor unit's control panel (AAI functions) if the unit is reset to the factory settings via the unit interface, and the installation assistant is then run again and the function is confirmed without the system control.

8.8 Energy balance control

The energy balance is the integral from the difference between the flow temperature actual value and target value, which is added up every minute. If the set heat deficit (WE = -60°min in heating mode) is reached, the heat pump starts. If the supplied heat volume corresponds to the heat deficit (integral = 0°min), the heat pump is switched off.

The energy balancing is used for heating and cooling mode.

8.9 Compressor hysteresis

The heat pump is switched on and off via the compressor hysteresis for heating mode and also for energy balancing. When the compressor hysteresis is above the target flow temperature, the heat pump is switched off. When the hysteresis is below the target flow temperature, the heat pump starts up again.

8.10 Enabling the electric back-up heater

On the system control, you can select whether the electric back-up heater is to be used for heating mode, domestic hot water mode or both modes. Set the maximum output for the electric back-up heater at the indoor unit's control panel here.

The electric back-up heater is controlled automatically and according to demand.

- ▶ Activate the internal electric back-up heater with one of the following output levels.
- ▶ You can find the output levels for the electric back-up heater in the tables in the appendix.
 - 5.4 kW back-up heater (→ Appendix J)
 - 8.54 kW back-up heater at 230 V (→ Appendix K)
 - 8.54 kW back-up heater at 400 V (→ Appendix L)
- ▶ Ensure that the maximum output for the electric back-up heater does not exceed the output of the fuse protection for the household electricity system (for rated currents, see Technical data). (→ Appendix R)



Note

Otherwise, the home's internal circuit breaker may trigger if, when there is insufficient heat source output, the electric back-up heater that is not derated is switched on.

8.11 Setting the anti-legionella function

- ▶ Set the anti-legionella function using the system control.





To ensure sufficient legionella protection, the electric back-up heater must be activated.

8.12 Purging

You can use the installation assistant to run through the purging programmes.

- ▶ To do this, read the purging section. (→ Section 8.4)

8.13 Calling up the installer level

1. Press  and  at the same time.
2. Navigate to **Menu** → **Installer level** and confirm by pressing  (**OK**).
3. Set the value **17** and confirm by pressing .

8.14 Restarting the installation assistants

You can restart the installation assistant at any time by calling it up in the menu.

Menu → **Installer level** → **Start inst. assistant**.

8.15 Checking the configuration

You can recheck and set the most important system parameters. Call up **Configuration** to configure the menu item.

Menu → **Installer level** → **Configuration**.

8.16 Calling up statistics

Menu → **Installer level** → **Test menu** → **Statistics**

You can use this function to call up the statistics for the heat pump.

8.17 Activating screed drying without the outdoor unit and without the system control



Caution.

Risk of damage to the product caused by impermissible purging

Without purging the heating circuit, the system may become damaged.

- ▶ If the screed drying is activated without a system control, purge the system manually. No automatic purging takes place.

Screed drying.

- You can use this function to "dry heat" freshly laid screed in accordance with the construction regulations, according to a defined time and temperature schedule, without having a system control or the outdoor unit connected.

When screed drying is activated, all the selected operating modes are interrupted. The function controls the flow temperature of the controlled heating circuit according to a pre-set programme, regardless of the outdoor temperature.

The display shows the target flow temperature. You can manually set the current day.

Days after starting the function	Target flow temperature for this day [°C]
1	25
2	30
3	35
4	40
5	45
6–12	45
13	40
14	35
15	30
16	25
17–23	10 (frost protection function, pump in operation)
24	30
25	35
26	40
27	45
28	35
29	25

The day is always changed at 00:00, irrespective of when the function starts.

After a mains Off/On, screed drying starts with the last active day.

The function ends automatically when the last day of the temperature profile has elapsed (day = 29) or if you set the start day to 0 (day = 0).

8.17.1 Activating the screed drying

1. Press the reset button.
2. When restarting the display, press and hold the **+** button until the language selection opens.
3. Set the required language. (→ Section 4.4.8)
4. Press the **☐** button in order to select the power supply for the back-up boiler.
 - 230 V
5. Press the **☐** button in order to select the output of the back-up boiler.
6. Press the **☐** button in order to select the start day for the screed drying.
 - ◁ The screed drying is started and the display shows the current flow temperature and the right-hand status bar shows the system pressure.
 - ▽ In the current programme, the current status messages for the system can be called up in the display.
 - ▶ Press the **☐** and **☐** buttons at the same time in order to display the status messages.
 - ▽ The settings for the function can be changed in the current programme.
 - ▶ Return to the programme steps in order to change the settings or the current day.
 - ◁ If the screed drying has not been run successfully by day 29, the display shows the message **Screed drying ending**.
 - ▽ If a fault occurs during screed drying, the display shows the message **Fault**.
 - ▶ Select a new start day for the screed drying or interrupt the process.

8.18 Activating cooling mode

- ▶ Go to the indoor unit's control panel.
- ▶ Navigate to: **Menu** → **Installer level** → **Configuration** → **Cooling technology**.
- ▶ Select: **Active cooling**.
- ▶ If this involves a heat pump cascade, implement this setting for every heat pump with cooling function.

Condition: System control connected

- ▶ Activate the cooling mode in the system control menu (→ Installation instructions for the system control).

8.19 Starting up the optional system control

The following work for starting up the system was carried out:

- The system control and the outdoor temperature sensor have been installed and wired.
- Start-up of all system components (except for the system control) is complete.

Follow the installation assistant and the operating and installation instructions for the system control.

8.20 Displaying the filling pressure in the building circuit

The product has a pressure sensor in the heating circuit and a digital pressure display.

- ▶ Select **Menu Live Monitor** to display the filling pressure in the building circuit.
 - ◁ To ensure that the building circuit works correctly, the filling pressure must be between 1 bar and 1.5 bar. If the heating installation extends over several storeys, higher filling pressures may be required to avoid air entering the heating installation.

8.21 Checking function and leak-tightness

Before you hand the product over to the end user:

- ▶ Check the heating installation (heat generator and system) and the domestic hot water pipes for tightness.
- ▶ Check whether the drain pipework for the purging connections has been installed correctly.

8.21.1 Checking the heating mode

- ▶ Follow the installation instructions for the system control.

8.21.2 Checking the hot water generation

- ▶ Follow the installation instructions for the system control.

9 Adapting the unit to the heating installation

9.1 Configuring the heating installation

The installation assistant is launched when the product is switched on for the first time. When the installation assistant is complete, you can further adjust the parameters of the installation assistant, for example, in the **Configuration** menu.

To adjust the water flow rate generated by the heat pump to match the specific installation, you can set the maximum available pressure for the heat pump in the heating and domestic hot water mode.

You can call up these two parameters via **Menu** → **Installer level** → **Configuration**.

The adjustment range is between 200 mbar and 900 mbar. The heat pump operates at its optimum level when the nominal flow can be achieved by setting the available pressure (Delta T = 5 K).

9.2 Remaining feed head of the product

The remaining feed head cannot be set directly. You can limit the remaining pump head in order to adjust the on-site pressure loss in the heating circuit.

The integrated pump attempts to achieve the nominal volume flow.

9.2.1 VWL 57/5 remaining feed head at nominal volume flow

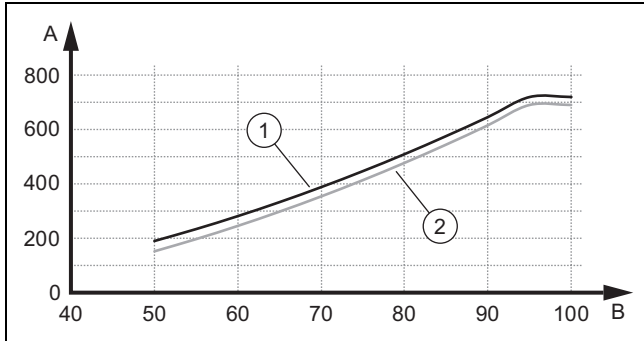

- | | | | |
|---|-----------------------------|---|--------------------------------------|
| 1 | VWL 57/5,
3.5 kW/540 l/h | A | Remaining feed head in
hPa (mbar) |
| 2 | VWL 57/5, 5 kW/790 l/h | B | Pump output in % |

9.2.2 VWL 77/5 remaining feed head at nominal volume flow

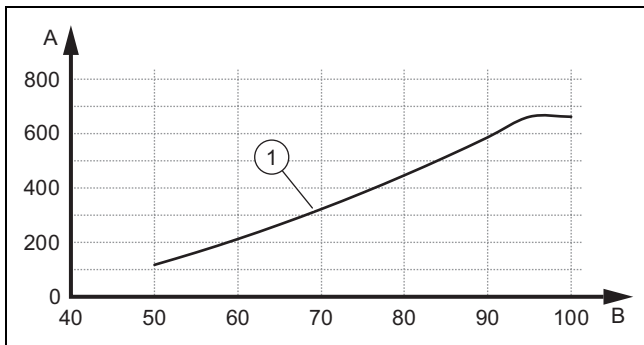

- | | | | |
|---|----------------------------|---|--------------------------------------|
| 1 | VWL 77/5,
7 kW/1020 l/h | A | Remaining feed head in
hPa (mbar) |
| | | B | Pump output in % |

9.2.3 VWL 127/5 remaining feed head at nominal volume flow

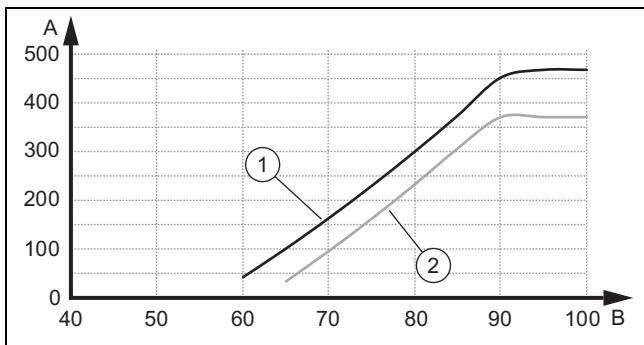

- | | | | |
|---|------------------------------|---|--------------------------------------|
| 1 | VWL 127/5,
10 kW/1670 l/h | A | Remaining feed head in
hPa (mbar) |
| 2 | VWL 127/5,
12 kW/1850 l/h | B | Pump output in % |

9.3 Setting the flow temperature in heating mode (with no control connected)

- Press (OK).
 - The display shows the flow temperature in heating mode.
- Change the flow temperature in heating mode by pressing or .
 - Max. heating mode target flow temperature: 75 °C
- Confirm this change by pressing (OK).

9.4 Instructing the end user



Danger!

Risk of death from legionella.

Legionella multiply at temperatures below 60 °C.

- ▶ Ensure that the end user is familiar with all of the Anti-legionella measures in order to comply with the applicable regulations regarding legionella prevention.

- ▶ Explain to the end user how the safety devices work and where they are located.
- ▶ Inform the end user how to handle the product.
- ▶ Draw particular attention to the safety warnings, which the end user must follow.
- ▶ Inform the end user that they must have the product maintained in accordance with the specified intervals.
- ▶ Explain to the end user how to check the system's water volume/filling pressure.
- ▶ Pass all of the instructions and documentation for the product to the end user for safe-keeping.

10 Troubleshooting

10.1 Contacting your service partner

If you contact your service partner, please mention if possible:

- The fault code that is displayed (**F.xx**)
- The status code (**S.xx**) that is displayed by the product in the Live Monitor

10.2 Displaying the Live Monitor (current product status)

Menu → Live Monitor

Status codes in the display provide information on the product's current operating mode. These can be called up via the **Live Monitor** menu.

Status codes (→ Appendix F)

10.3 Checking fault codes

The display shows a fault code **F.xxx**.

Fault codes have priority over all other displays.

Fault codes (→ Appendix I)

If multiple faults occur at the same time, the display shows the corresponding fault codes for two seconds each in sequence.



- ▶ Eliminate the fault.
- ▶ To restart the product, press the reset button (Operating instructions).
- ▶ If you are unable to eliminate the fault and the fault recurs despite several reset attempts, contact Customer Service.

10.4 Querying the fault memory

Menu → Installer level Fault list

The product has a fault memory. You can use this to query the last ten faults that occurred in chronological order.

Display views:

- Number of faults that occurred
- The fault currently selected with fault number **F.xxx**
- A plain text display explaining the fault.
- ▶ Use the  or  button to display the last ten faults that occurred.

10.5 Resetting the fault memory

- ▶ Press  twice and then **Delete** and **OK** to delete the fault list.

10.6 Using the function menu

You can use the function menu to actuate and test individual components of the product during the fault diagnostics. (→ Section 10.8)

10.7 Using check programmes

You can call up the check programmes via **Menu → Installer level → Test menu → Check programmes**.

You can activate various special functions in the product by using various check programmes.

If the product is in error condition, you cannot start any check programmes. You can detect an error condition by the fault symbol shown in the left bottom corner of the display. You must first reset.

To end the check programmes, you can press **Cancel** at any time.

10.8 Carrying out the actuator test

Menu → Installer level → Test menu → Sensor/actuator test

You can check that the components of the heating installation are functioning correctly using the sensor/actuator test. You can actuate more than one actuator at a time.

If you do not select anything to change, you can have the current control values for the actuators and the sensor values displayed.

You can find a list of the sensor characteristic values in the appendix.

Characteristic values for the temperature sensor, refrigeration circuit (→ Appendix N)

Characteristic values for the internal temperature sensors, hydraulic circuit (→ Appendix O)

Characteristic values for the VRC DCF outdoor temperature sensor (→ Appendix Q)

10.9 Resetting parameters to factory settings

- ▶ Select **Menu → Installer level → Resets** to reset all of the parameters at the same time and to restore the product to the factory settings.

10.10 Preparing the repair work

1. Switch off the product.
2. Disconnect the product from the power supply.
3. Secure the product against being switched back on again.
4. Remove the front casing.
5. Close the service valves in the heating flow and in the heating return.
6. Close the service valve in the cold water pipe.
7. Drain the product if you want to replace water-carrying components of the product.
8. Ensure that water does not drip on live components (e.g. the electronics box).
9. Use only new seals.

10.11 Safety cut-out

The product has a safety cut-out.

If the safety cut-out has tripped, the cause must be eliminated and the safety cut-out replaced.

- ▶ See the "Fault codes" table in the appendix. Fault codes (→ Appendix I)
- ▶ Check the back-up heater for damage due to overheating.
- ▶ Check that the power supply for the power supply PCB is working properly.
- ▶ Check the cabling for the power supply PCB.
- ▶ Check the cabling for the back-up heater.
- ▶ Check that all temperature sensors are working properly.
- ▶ Check that all other sensors are working properly.
- ▶ Check the pressure in the heating circuit.
- ▶ Check that the heating circuit pump is working properly.
- ▶ Check whether there is air in the heating circuit.

10.11.1 Replace the safety cut-out

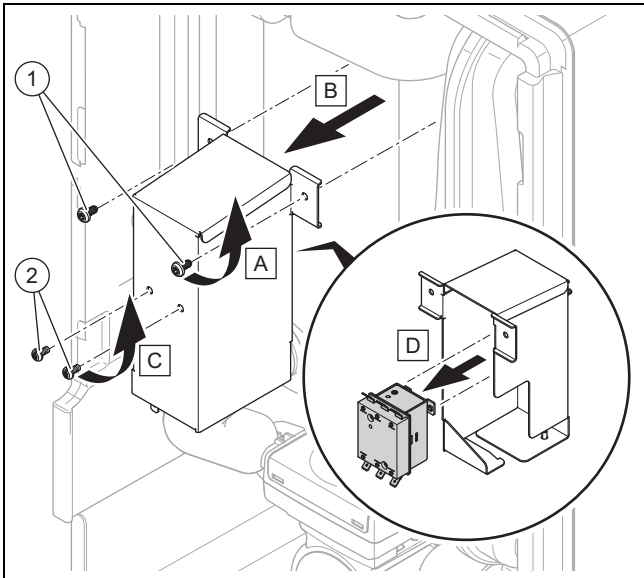

1. Disconnect the product from the power grid and protect it against being switched back on.
2. Remove the front casing.
3. Remove both screws (1) and remove the safety cut-out with the retainer from the product.
4. Remove all cables from the safety cut-out. Observe the closing mechanism for the cable duct.
5. Remove the safety cut-out from the retainer by undoing the two screws (2).
6. Undo the nuts on the upper side of the back-up heater and remove the temperature sensor.
7. Connect cables of the same colour to opposite sides of each other on the safety cut-out.
8. Install the new safety cut-out in reverse order.

11 Inspection and maintenance

11.1 Inspection and maintenance information

11.1.1 Inspection

The inspection is intended to determine the actual condition of a product and compare it with the target condition. This is done by measuring, checking and observing.

11.1.2 Maintenance

Maintenance is required in order to eliminate any deviations between the actual condition and the target condition. This is normally done by cleaning, setting and, if necessary, replacing individual components that are subject to wear.

11.2 Procuring spare parts

The original components of the product were also certified by the manufacturer as part of the declaration of conformity. If you use other, non-certified or unauthorised parts during maintenance or repair work, this may result in the product no longer meeting the applicable standards, thereby voiding the conformity of the product.

We strongly recommend that you use original spare parts from the manufacturer as this guarantees fault-free and safe operation of the product. To receive information about the available original spare parts, contact the contact address provided on the back page of these instructions.

- ▶ If you require spare parts for maintenance or repair work, use only the spare parts that are permitted for the product.

11.3 Checking maintenance messages

If the  symbol is shown in the display, the product requires maintenance work or the product is in comfort protection mode.

- ▶ To obtain further information, call up the **Live Monitor**.
- ▶ Carry out the maintenance work that is listed in the table. Maintenance messages (→ Appendix G)

Condition: Lhm.XX is displayed

The product is in Comfort protection mode. The product has detected a permanent fault and continues to run with restricted comfort.

- ▶ To determine which component is defective, read the fault memory (→ Section 10.4).



Note

If a fault message is present, the product remains in comfort protection mode after it is reset. After the product is reset, the fault message is displayed first before the message **Limp home mode (comfort protection)** appears again.

- ▶ Check the component that is displayed and replace it.

11.4 Observing inspection and maintenance intervals

- ▶ Adhere to the minimum inspection and maintenance intervals. Carry out all of the work that is listed in the "Inspection and maintenance work" table in the appendix.
- ▶ Carry out maintenance work on the product at an earlier point if the results of the inspection that was carried out during previous maintenance make this necessary.

11.5 Preparing for inspection and maintenance

Observe the basic safety rules before carrying out inspection and maintenance work or installing spare parts.

- ▶ Switch off the product.
- ▶ Disconnect the product from the power supply.
- ▶ Secure the product against being switched back on again.
- ▶ When working on the product, protect all electric components from spraying water.
- ▶ Remove the front casing.

11.6 Checking the pre-charge pressure of the expansion vessel

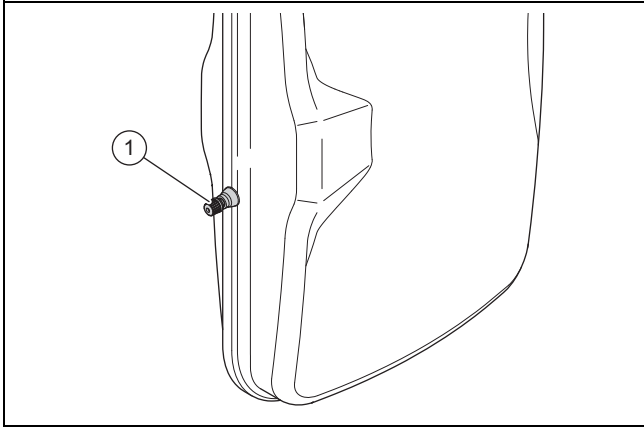

1. Close the service valves and drain the heating circuit. (→ Section 12.1)
2. Measure the pre-charge pressure of the expansion vessel (1) at the valve (2).

Result:



Note

The required pre-charge pressure of the heating installation may vary depending on the static pressure (0.1 bar per metre in height).

Pre-charge pressure is below 0.75 bar (± 0.1 bar/m)

- ▶ Fill the expansion vessel with nitrogen. If nitrogen is not available, use air.
3. Fill the heating circuit. (→ Section 8.3)

11.7 Checking and correcting the filling pressure of the heating installation

If the filling pressure falls below the minimum pressure, a maintenance message is shown on the display.

- Min. heating circuit pressure: ≥ 0.05 MPa (≥ 0.50 bar)
- ▶ Top up the heating water in order to start up the heat pump again; Filling and purging the heating installation (→ Section 8.3).
- ▶ If you notice frequent pressure losses, determine and eliminate the cause.

11.8 Checking the high-pressure switch-off

- ▶ Start check programme P.29 **High pressure**.
 - ◁ The compressor starts and the flow rate monitoring for the pump is deactivated.
- ▶ Block the heating circuit.
 - ◁ The product is switched off by the high-pressure switch-off.

11.9 Completing inspection and maintenance



Warning.

Risk of burns due to hot and cold components.

There is a risk of burns from any uninsulated pipelines and from the electric back-up heater.

- ▶ Before starting up the unit, install any casing sections that have been removed.

1. Start up the heat pump system.
2. Check that the heat pump system is working without any problems.

12 Draining

12.1 Draining the product's heating circuit

1. Close the service valves in the heating flow and in the heating return.
2. Remove the front casing. (→ Section 4.7)

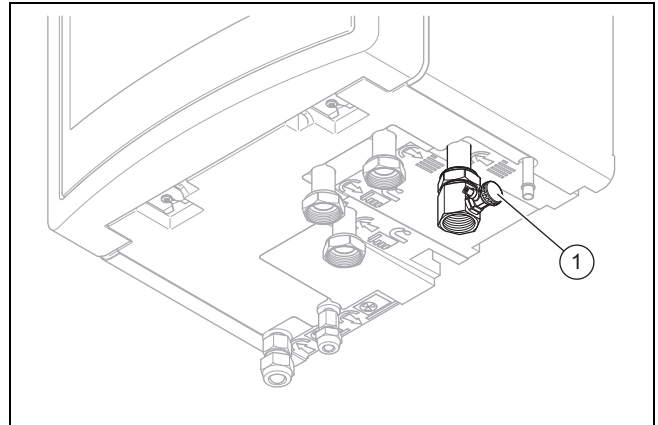

3. Connect a hose to the filling device (1) and guide the free end of the hose to a suitable drainage point.
4. Use manual actuation to move the prioritising diverter valve to the "Heating circuit/domestic hot water cylinder" position. (→ Section 8.1)
5. Open the stopcock on the filling device.
6. Open the automatic air vent.
7. Use the expansion relief valve to check whether the heating circuit has been completely drained.
 - ◁ Residual hot water may escape from expansion relief valve's drain.

13 Decommissioning

13.1 Temporarily decommissioning the product

1. Switch off all of the disconnectors to which the product is connected in the building.
2. Disconnect the product from the power supply.

13.2 Permanently decommissioning the product

1. Switch off all of the disconnectors to which the product is connected in the building.
2. Disconnect the product from the power supply.



Caution.

Risk of material damage when extracting refrigerant.

When extracting refrigerant, there is a risk of material damage caused by freezing.

- ▶ Ensure that heating water flows through the indoor unit's condenser or it is completely drained when extracting refrigerant on the secondary side.

3. Extract the refrigerant.
4. Close the cold-water stopcock.
5. Close the stopcocks.
6. Drain the product.
7. Dispose of or recycle the product and its components.

14 Recycling and disposal

14.1 Disposing of the packaging

- ▶ Dispose of the packaging correctly.
- ▶ Observe all relevant regulations.
- ▶ For detailed information refer to www.vaillant.co.uk.

14.2 Disposing of the product and accessories

- ▶ Do not dispose of the product or the accessories with household waste.
- ▶ Dispose of the product and all accessories correctly.
- ▶ Observe all relevant regulations.

14.3 Disposing of the refrigerant



Warning.

Risk of damage to the environment.

The product contains the refrigerant R410A. This refrigerant must not be allowed to escape into the atmosphere. R410A is a fluorinated greenhouse gas covered by the Kyoto Protocol, with a GWP of 2088 (GWP = Global Warming Potential).

- ▶ Before the product is disposed of, have the refrigerant which it contains completely drained into a suitable vessel so that it can then be recycled or disposed of in accordance with regulations.



Caution.

Risk of damage caused by defrosting.

Draining off the refrigerant generates intense cooling of the indoor unit's plate heat exchanger, which may lead to the de-icing of the plate heat exchanger on the heating water side.

- ▶ Drain the indoor unit on the heating water side in order to prevent damage.
- ▶ Ensure that, during the refrigerant draining of the plate heat exchanger on the heating water side, there is sufficient flow-through.

- ▶ Ensure that the refrigerant is disposed of by a qualified competent person.

15 Customer service

For contact details for our customer service department, you can write to the address that is provided on the back page, or you can visit www.vaillant.co.uk.

Appendix

A Wiring diagram

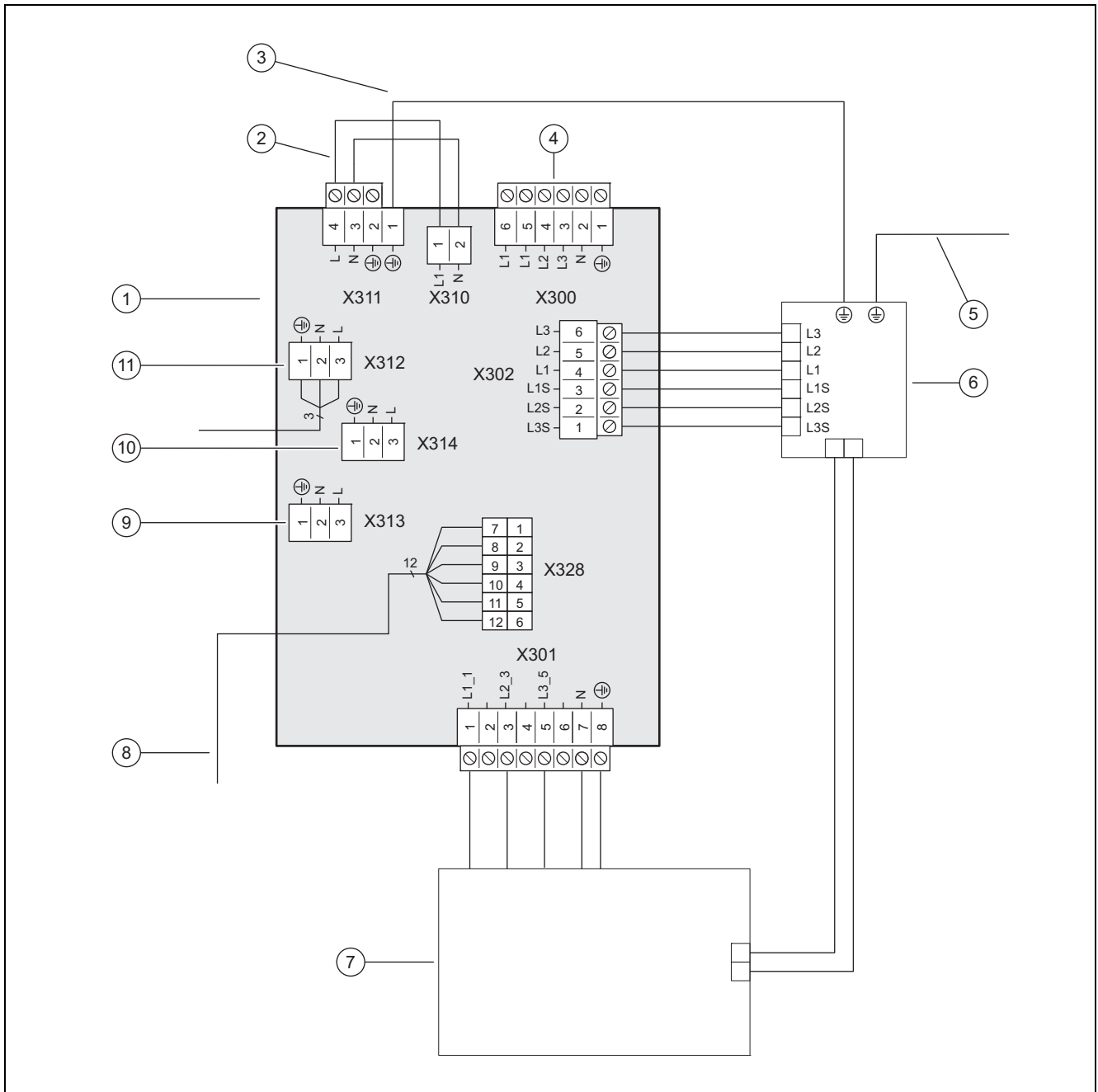

- | | | | |
|---|--|----|---|
| 1 | Power supply PCB | 8 | [X328] Data connection to the control PCB |
| 2 | For single power supply: 230 V bridge between X311 and X310; for dual power supply: Replace the bridge at X311 with the 230 V connection | 9 | [X313] Power supply for the control PCB or the optional VR 70/VR 71 or the optional external current anode |
| 3 | Earth wire | 10 | [X314] Power supply for the control PCB or the optional VR 70/VR 71 or the optional external current anode |
| 4 | [X300] Power supply connection | 11 | [X312] Power supply for the control PCB or the optional VR 70/VR 71 or the optional external current anode |
| 5 | Earth wire to X1 on the control PCB | | |
| 6 | [X302] Safety cut-out | | |
| 7 | [X301] Back-up heater | | |

B Control PCB

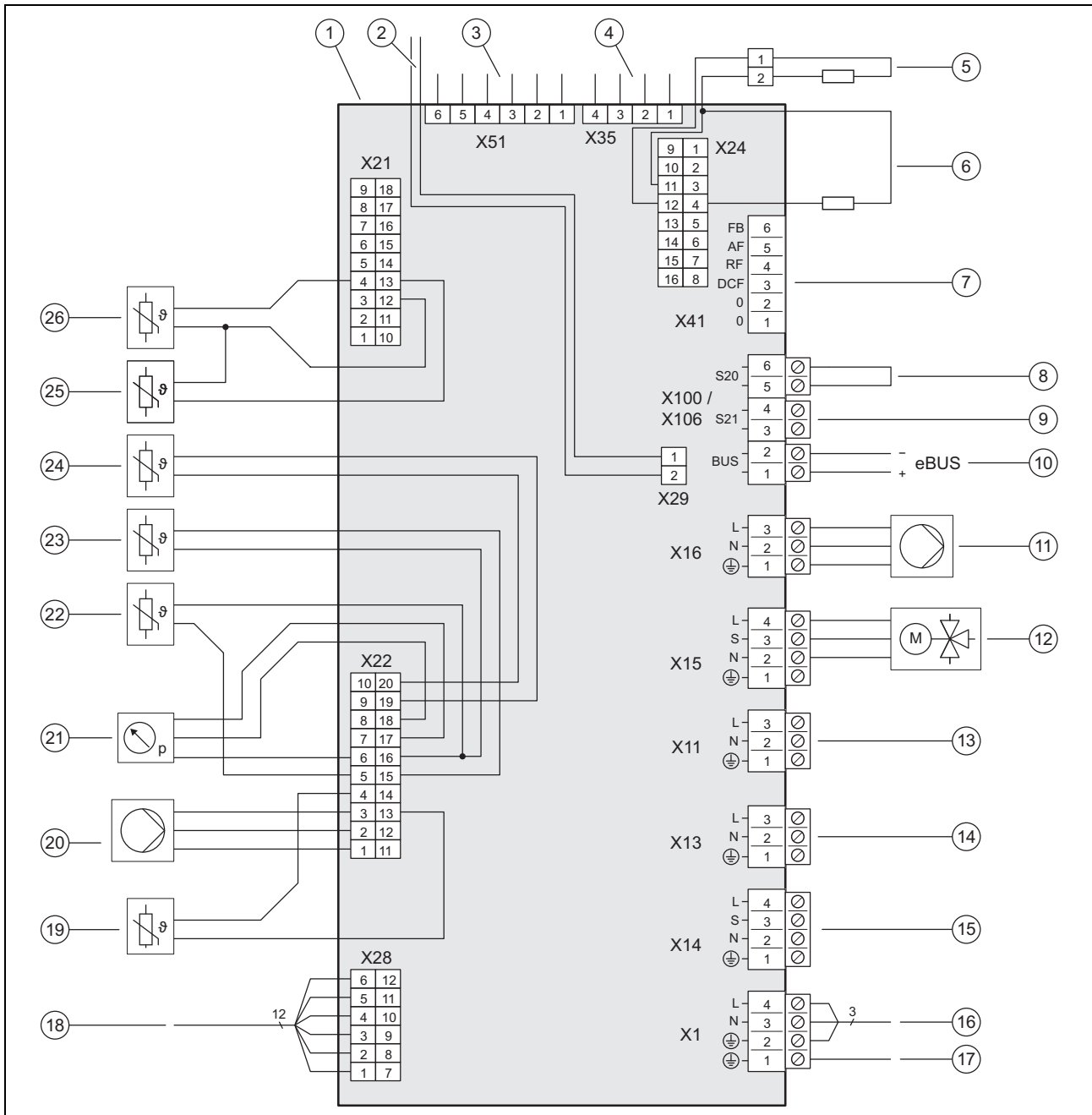

- | | | | |
|----|---|----|--|
| 1 | Control PCB | 13 | [X11] Multi-function output 2: Domestic hot water circulation pump, anti-legionella pump, dehumidifier, zone valve |
| 2 | [X29] eBUS bus connection for the installed system control | 14 | [X13] Multi-function output 1: Cooling valve |
| 3 | [X51] Display edge connector | 15 | [X14] Multi-function output: External back-up heater, external prioritising diverter valve, external fault message |
| 4 | [X35] Edge connector (external current anode) | 16 | [X1] 230 V supply for control PCB |
| 5 | [X24] Coding resistor 3 | 17 | Earth wire for the power supply PCB |
| 6 | [X24] Coding resistor 2 | 18 | [X28] Data connection to the power supply PCB |
| 7 | [X41] Edge connector (outdoor temperature sensor, DCF, system temperature sensor, multi-function input) | 19 | [X22] Immersion heater flow temperature sensor |
| 8 | [X106/S20] Limit thermostat | 20 | [X22] Heating pump signal |
| 9 | [X106/S21] ESCO contact | 21 | [X22] Pressure sensor |
| 10 | [X106/BUS] eBUS bus connection (outdoor unit, VRC 700, VR 70 / VR 71) | 22 | [X22] Building circuit flow temperature sensor |
| 11 | [X16] Internal heating pump | 23 | [X22] Building circuit return temperature sensor |
| 12 | [X15] Internal prioritising diverter valve for heating circuit/cylinder charging | | |

- 24 [X22] Domestic hot water cylinder temperature sensor
- 25 [X21] Condenser outlet temperature sensor (EEV outlet)

26 [X21] Condenser inlet temperature sensor

C Basic connection diagram for the energy supply company lockout, shutdown via connection S21

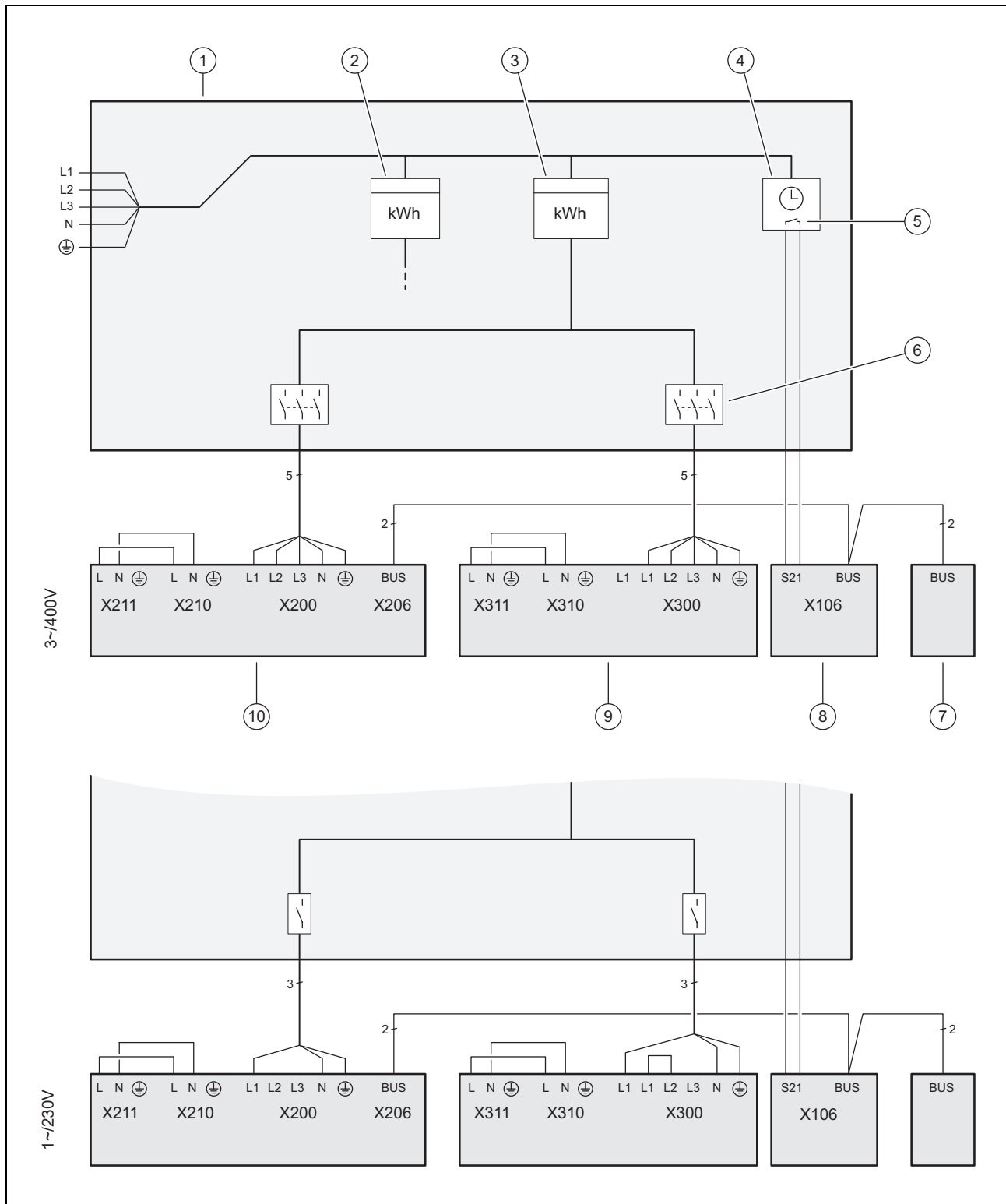

- | | |
|---|---|
| <ul style="list-style-type: none"> 1 Meter/fuse box 2 Household electricity meter 3 Heat pump electricity meter 4 Ripple control receiver | <ul style="list-style-type: none"> 5 Potential-free normally open contact, for actuating S21, for the energy supply company lockout function 6 Disconnector (circuit breaker, fuse) 7 System control |
|---|---|

D Basic connection diagram for the energy supply company lockout, shutdown via partition

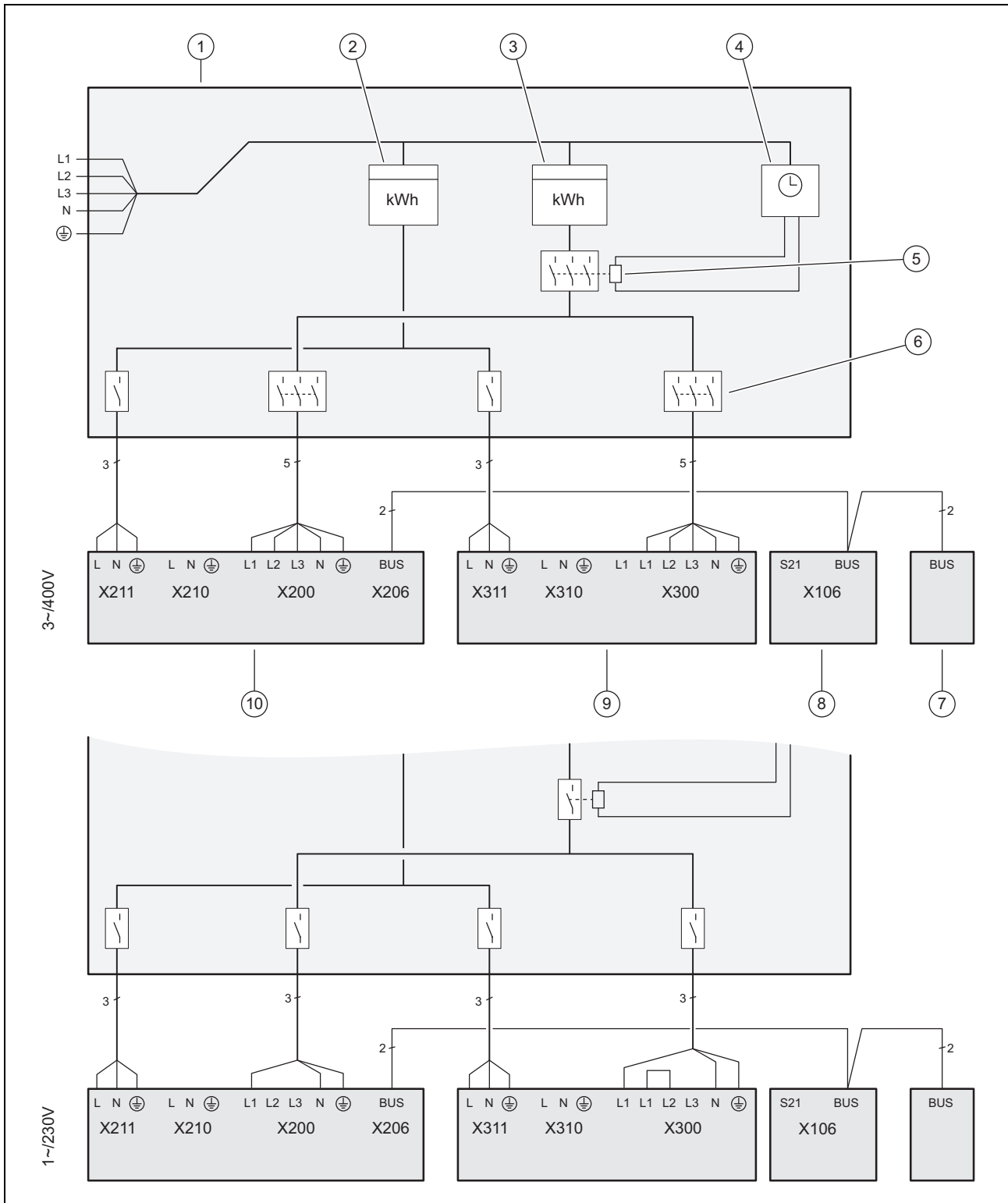

- | | | | |
|---|---|----|--------------------------------------|
| 1 | Meter/fuse box | 6 | Disconnecter (circuit breaker, fuse) |
| 2 | Household electricity meter | 7 | System control |
| 3 | Heat pump electricity meter | 8 | Indoor unit, control PCB |
| 4 | Ripple control receiver | 9 | Indoor unit, power supply PCB |
| 5 | Partition, for the energy supply company lockout function | 10 | Outdoor unit, PCB INSTALLER BOARD |

E Installer level overview

Setting level	Values		Unit	Increment, select, explanation	Factory setting	Setting
	Min.	Max.				
Installer level →						
Enter code	00	99		1 (competent person code 17)	00	
Installer level → Fault list →						
F.XX – F.XX ¹⁾	Current value					
Installer level → Test menu → Statistics →						
Compressor hours	Current value		h			
Compressor starts	Current value					
Build. pump hours	Current value		h			
Build. pump starts	Current value					
4-port valve hours	Current value		h			
4-port valve sw. ops	Current value					
Fan 1 operating hours	Current value		h			
Fan 1 starts	Current value					
Fan 2 operating hours	Current value		h			
Fan 2 starts	Current value					
EEV steps	Current value					
DHW PDV switch. ops	Current value					
Im. heater power cons.	Current value		kWh			
Im. heater op. hours	Current value		h			
Im. heater switch. ops	Current value					
No. switch. ops	Current value					
Installer level → Test menu → Check programmes →						
P.04 Heating mode				Select		
P.06 Purge building circuit				Select		
P.11 Cooling mode				Select		
P.12 De-icing				Select		
P.27 Immersion heater				Select		
P.29 High pressure				Select		
Installer level → Test menu → Sensor/actuator test →						
T.0.01 Building circuit pump power	0	100	%	5, off	0	
T.0.17 Fan 1	0	100	%	5	0	
T.0.18 Fan 2	0	100	%	5	0	
T.0.19 Condensate tray heater	Off	On		On, Off		
T.0.20 4-port valve	Off	On		On, Off		
T.0.21 Position: EEV	0	100	%	5	0	
T.0.23 Heating coil compressor	Off	On		On, Off		
T.0.48 Air inlet temperature	-40	90	°C	0.1		
T.0.55 Compressor outlet temperature	-40	135	°C	0.1		
¹⁾ See the overview of fault codes: Fault lists are only available, and can only be deleted, if faults have occurred. ²⁾ This parameter does not appear if a system control is connected. ³⁾ This parameter only appears if a system control is connected.						

Setting level	Values		Unit	Increment, select, explanation	Factory setting	Setting
	Min.	Max.				
T.0.56 Compressor inlet temperature	-40	135	°C	0.1		
T.0.57 EEV outlet temperature	-40	90	°C			
T.0.63 High pressure	0	42.5	bar (abs)	0.1		
T.0.67 High-pressure switch	Closed	Open		Closed, Open		
T.0.85 Evaporation temperature	-40	90	°C	0.1		
T.0.86 Condensation temperature	-40	70	°C	0.1		
T.0.87 Overheating target value	-40	90	K	0.1		
T.0.88 Overheating actual value	-40	90	K	0.1 to 20 K are normal operating parameters		
T.0.89 Subcooling target value	-40	90	K	0.1		
T.0.90 Subcooling actual value	-40	90	K	0.1		
T.0.93 Compressor speed	0	120	Rotation/s	1		
T.0.123 Temperature switch: Compressor outlet	Off	On		On, Off		
T.1.02 DHW prioritising diverter valve	Heating	Domestic hot water		Heating, domestic hot water	Heating	
T.1.40 Flow temperature	-40	90	°C	0.1		
T.1.41 Return temperature	-40	90	°C	0.1		
T.1.42 Building circuit: Water Pressure	0	3	bar	0.1		
T.1.43 Building circuit: Flow rate	0	4000	l/h	1		
T.1.44 Cylinder temperature	-40	90	°C	0.1		
T.1.46 Lockout contact S20	Closed	Open		Closed, Open	Closed	
T.1.59 Condenser outlet temperature	-40	90	°C	0.1		
T.1.69 Outdoor temperature	-40	90	°C	0.1		
T.1.70 System temperature	-40	90	°C	0.1		
T.1.71 DCF status	Current value			No DCF signal Validate DCF signal Valid DCF signal		
T.1.72 Lockout contact S21	Closed	Open		Closed, Open	Open	
T.1.119 MO1 output	Off	On		Off, On	Off	
T.1.124 Safety cut-out immersion heater	Closed	Open		Closed, Open	Closed	
T.1.125 MPI input	Current value					
T.1.126 MO2 output	Off	On		Off, On	Off	
T.1.127 MO output	Off	On		Off, On	Off	
Installer level → Configuration →						
Language	Current language			Languages available for selection	02 English	
Contact details → Telephone number	Phone number			0-9		
Heat curve ²⁾	0.4	4.0		0.1		
Summer sw.-off temp. ²⁾	10	90	°C	1		
Heating biv. point ²⁾	-30	+20	°C	1		
DHW bivalence point ²⁾	-20	+20	°C	1		
Heating alt. point ²⁾	-20	+40	°C	Off, 1		
¹⁾ See the overview of fault codes: Fault lists are only available, and can only be deleted, if faults have occurred.						
²⁾ This parameter does not appear if a system control is connected.						
³⁾ This parameter only appears if a system control is connected.						

Setting level	Values		Unit	Increment, select, explanation	Factory setting	Setting
	Min.	Max.				
Max. flow temperature ²⁾	15	90	°C	1		
Heating mode activ. ²⁾				On, Off		
DHW activation ²⁾				On, Off		
Cyl. charg. hysteresis ²⁾	3	20	K	1		
Immers. heater mode ²⁾				Off, Heating+DHW, Heating, Domestic hot water		
Limp home mode ²⁾				Off, Heating, Domestic hot water, Heating+domestic hot water		
Cooling target flow ²⁾	7	24	°C	1		
MO relay				Fault signal, Ext. immersion heater, DHW 3-port valve, None		
Compr.start heat. from	-100	-30	°min	1	-60	
Compr.start cool. from	30	100	°min	1	60	
Compressor hyster.	3	15	K	Applies for heating mode only: 1	7	
Max. rem. feed head	200	1100	mbar	10	1100	
DHW mode	0 = ECO	1 = Normal		0, 1	0	
Max. anti-cycl. time	0	9	h	1	5	
Reset anti-cycl. time → Anti-cycl. time after pow. supp. switch-on	0	120	min	1	0	
Im. heater outp. range	External	9	kW	5 kW and 7 kW: 230 V and 400 V: 1-6: 1 kW – 6 kW 12 kW, 230 V: 1-6: 1 kW – 6 kW 12 kW, 400 V: 1-9: 1 kW – 9 kW	6 or 9	
Compr. current limit				VWL 58/5 IS + VWL 78/5 IS: 13-16 A VWL 128/5 IS: 20-25 A		
Compr. noise reduct. ³⁾	40	60	%	1	40	
Soft modulation	Off	On		Off, On	On	
Only for products with cooling: Cooling technology	None	Active cooling		None, active cooling	None	
Output limit signal received				Received, Not received		
Current output limit of the heat pump			kW	Output limit of the heat pump in kW		
Current output limit of the electric back-up heater			kW	Output limit of the electric back-up heater in kW		

¹⁾ See the overview of fault codes: Fault lists are only available, and can only be deleted, if faults have occurred.

²⁾ This parameter does not appear if a system control is connected.

³⁾ This parameter only appears if a system control is connected.

Setting level	Values		Unit	Increment, select, explanation	Factory setting	Setting
	Min.	Max.				
Electric back-up heater connected	Yes	No		The parameters are displayed if MO relay : "Ext. immersion heater" and Im. heater outp. range : "External" are set.	Yes	
Software version	Current value of the control PCB (HMU indoor unit xxxx, HMU outdoor unit xxxx) and the display (AI xxxx)			xxxx.xx.xx		
Installer level → Resets →						
Statistics → Reset statistics?				Yes, No	No	
High-pressure switch → Reset fault?				Yes, No	No	
Factory settings → Restore factory settings				Yes, No	No	
Installer level → Start inst. assistant →						
Language				Languages available for selection	02 English	
Syst. control avail.?	Yes	No		Yes, No		
Im. heater power supp.	230 V	400 V				
Im. heater outp. range	External	9	kW	5 kW and 7 kW: 230 V and 400 V: 1–6: 1 kW – 6 kW 12 kW, 230 V: 1–6: 1 kW – 6 kW 12 kW, 400 V: 1–9: 1 kW – 9 kW	6 or 9	
Cooling technology	No cooling	Active cooling				
Compr. current limit	13	25	A	1 5 – 7 kW: 13 – 16 A 12 kW: 20 – 25 A		
MO relay				None, fault signal, ext. immersion heater, DHW 3WV	None	
Check program: Purge building circuit	Yes	No		Yes, No	No	
Contact details Telephone number	Phone number			0–9	Empty	
End the installation assistant?				Yes, back		
¹⁾ See the overview of fault codes: Fault lists are only available, and can only be deleted, if faults have occurred. ²⁾ This parameter does not appear if a system control is connected. ³⁾ This parameter only appears if a system control is connected.						

F Status codes

Code	Meaning
S.34 Heating mode: Frost protection	If the measured outdoor temperature falls below XX °C, the temperature of the heating circuit's flow and return is monitored. If the temperature difference exceeds the set value, the pump and compressor are started without a heat demand.
S.100 Standby	There is no heat demand or cooling demand. Standby 0: Outdoor unit. Standby 1: Indoor unit
S.101 Heating: Compressor shutdown	The heat demand is met, the demand is ended by the system control and the heat deficit is offset. The compressor is switched off.
S.102 Heating: Compressor blocked	The compressor is blocked for heating mode because the heat pump is outside of its application limits.
S.103 Heating: Prerun	The start conditions for the compressor in heating mode are checked. Start the other actuators for heating mode.
S.104 Heating: Compressor active	The compressor works in order to meet the heat demand.
S.107 Heating: Overrun	The heat demand is met, the compressor is switched off. The pump and fan overrun.
S.111 Cooling: Compressor shutdown	The cooling demand is met, the demand is ended by the system control. The compressor is switched off.
S.112 Cooling: Compressor blocked	The compressor is blocked for cooling mode because the heat pump is outside of its application limits.
S.113 Cooling: Compressor mode prerun	The start conditions for the compressor in cooling mode are checked. Start the other actuators for cooling mode.
S.114 Cooling: Compressor active	The compressor works in order to meet the cooling demand.
S.117 Cooling: Compressor mode overrun	The cooling demand is met, the compressor is switched off. The pump and fan overrun.
S.125 Heating: Immersion heater active	The immersion heater is used in heating mode.
S.132 Domestic hot water: Compressor blocked	The compressor is blocked for domestic hot water mode because the heat pump is outside of the application limits.
S.133 Domestic hot water: Prerun	The start conditions for the compressor in domestic hot water mode are checked. Start the other actuators for domestic hot water mode.
S.134 Domestic hot water: Compressor active	The compressor works in order to meet the domestic hot water demand.
S.135 Domestic hot water: Immersion heater active	The immersion heater is used in domestic hot water mode.
S.137 Domestic hot water: Overrun	The domestic hot water demand is met, the compressor is switched off. The pump and fan overrun.
S.141 Heating: Immersion heater shutdown	The heat demand is met, the immersion heater is switched off.
S.142 Heating: Immersion heater blocked	The immersion heater is blocked for heating mode.
S.151 Domestic hot water: Immersion heater shutdown	The domestic hot water demand is met, the immersion heater is switched off.
S.152 Domestic hot water: Immersion heater blocked	The immersion heater is blocked for domestic hot water mode.
S.173 Anti-cycling time for the energy supply company	The mains voltage supply is interrupted by the energy supply company. The maximum anti-cycling time is set in the configuration.
S.176 External electrical power limitation is active	The heat pump or the electric back-up heater is limited by the energy supply company.
S.202 Check programme: Purging of building circuit active	The building circuit pump is actuated in cyclical intervals, alternately in heating mode and domestic hot water mode.
S.203 Actuator test active	The sensor and actuator test is currently operating.
S.212 Connection fault: Control not recognised	System control was previously detected but the connection is broken. Check the eBUS connection to the system control. It can only be operated with the heat pump's additional functions.
S.240 Compr. oil temp. too low, environment too cold	The compressor heating is switched on. The unit does not start up.
S.252 Fan unit 1: Fan blocked	If the fan speed is 0 rpm, the heat pump is switched off for 15 minutes and then restarted. If the fan does not start up after four unsuccessful restarts, the heat pump is switched off and the fault message F.718 is displayed.
S.255 Fan unit 1: Air inlet temp. too high	The compressor does not start because the outdoor temperature at the fan is above the application limits. Heating mode: > 43 °C. Domestic hot water mode: > 43 °C. Cooling mode: > 46 °C.

Code	Meaning
S.256 Fan unit 1: Air inlet temp. too low	The compressor does not start because the outdoor temperature at the fan is below the application limits. Heating mode: < -20 °C. Domestic hot water mode: < -20 °C. Cooling mode: < 15 °C.
S.260 Fan unit 2: Fan blocked	If the fan speed is 0 rpm, the heat pump is switched off for 15 minutes and then restarted. If the fan does not start up after four unsuccessful restarts, the heat pump is switched off and the fault message F.785 is displayed.
S.272 Building circuit: Remaining feed head limit active	The remaining feed head that is set under the configuration is reached.
S.273 Building circuit: Flow temperature too low	The flow temperature that is measured in the building circuit is below the application limits.
S.275 Building circuit: Flow rate too low	Building circuit pump defective. All consumers in the heating system are closed. The values fall below the specific minimum volume flows. Check that the dirt filter is permeable. Check the stopcocks and thermostatic valves. Ensure that the flow rate is at least 35% of the nominal flow rate. Check that the building circuit pump functions correctly.
S.276 Building circuit: Lock-out contact S20 open	Contact S20 is open at the heat pump's main PCB. Incorrect limit thermostat setting. Flow temperature sensor (heat pump, gas-fired boiler, system sensor) measures values that deviate downwards. Adjust the maximum flow temperature for the direct heating circuit via the system control (observe the upper switch-off threshold for the boilers). Adjust the set value for the limit thermostat. Check the sensor values
S.277 Building circuit: Pump fault	If the building circuit pump is inactive, the heat pump is switched off for 10 minutes and is then restarted. If the building circuit pump does not start up after three unsuccessful restarts, the heat pump is switched off and the fault message F.788 is displayed.
S.280 Freq. converter fault: Compressor	The compressor motor or wiring is defective.
S.281 Freq. converter fault: Mains voltage	There is overvoltage or undervoltage.
S.282 Freq. converter fault: Overheating	If the cooling of the frequency inverter is not sufficient, the heat pump is switched off for one hour and then restarted again. If the cooling is not sufficient after three unsuccessful restarts, the heat pump is switched off and the fault message F.819 is displayed.
S.283 De-icing time too long	If the de-icing takes longer than 15 minutes, the heat pump is restarted. If the time for the de-icing is still not sufficient after three unsuccessful restarts, the heat pump is switched off and the fault message F.741 is displayed. ► Check whether sufficient heat energy is available from the building circuit.
S.284 De-icing flow temperature too low	If the flow temperature is below 5 °C, the heat pump is restarted. If the flow temperature is still not sufficient after three unsuccessful restarts, the heat pump is switched off and the fault message F.741 is displayed. ► Check whether sufficient heat energy is available from the building circuit.
S.285 Compressor outlet temperature too low	Compressor outlet temperature is too low
S.286 Hot gas temperature switch open	If the hot gas temperature is above 119 °C +5 K, the heat pump is switched off for one hour and then restarted again. If the hot gas temperature has not fallen after three unsuccessful restarts, the heat pump is switched off and the fault message F.823 is displayed.
S.287 Fan 1: Wind	Before starting, the fan rotates at a speed of 50 rpm or higher. This may be caused by a strong outside wind.
S.288 Fan 2: Wind	Before starting, the fan rotates at a speed of 50 rpm or higher. This may be caused by a strong outside wind.
S.289 Current limit active	The outdoor unit's power consumption is reduced, the compressor speed is reduced. The compressor's operating current exceeds the limit value that is set under the configuration. (for 3 kW, 5 kW, 7 kW units: <16 A; for 10 kW, 12 kW units: <25 A)
S.290 Switch-on delay active	The compressor's switch-on delay is active.
S.302 High-pressure switch open	If the pressure in the refrigerant circuit exceeds the application limit, the heat pump is switched off for 15 minutes and is then restarted again. If the pressure remains too high after four unsuccessful restarts, the fault message F.731 is displayed.
S.303 Compressor outlet temperature too high	The operating characteristics have been exited. The heat pump is restarted.
S.304 Evaporation temperature too low	The operating characteristics have been exited. The heat pump is restarted.
S.305 Condensation temperature too low	The operating characteristics have been exited. The heat pump is restarted.
S.306 Evaporation temperature too high	The operating characteristics have been exited. The heat pump is restarted.
S.308 Condensation temperature too high	The operating characteristics have been exited. The heat pump is restarted.
S.312 Building circuit: Return temperature too low	Return temperature in the building circuit too low for compressor to start. Heating: Return temperature < 5 °C. Cooling: Return temperature < 10 °C. Cooling: Check that the 4-port diverter valve works correctly.

Code	Meaning
S.314 Building circuit: Return temperature too high	Return temperature in the building circuit too high for the compressor to start. Heating: Return temperature > 56 °C. Cooling: Return temperature > 35 °C. Cooling: Check that the 4-port diverter valve works correctly. Check the sensors.
S.351 Immersion heater: Flow temp. too high	The flow temperature at the immersion heater is too high. Flow temperature > 75 °C. The heat pump is switched off.
S.516 De-icing mode active	The heat pump de-ices the outdoor unit's heat exchanger. The heating mode is interrupted. The maximum de-icing time is 16 minutes.
S.575 Frequency converter: Internal fault	An internal electronics fault is present on the outdoor unit's inverter PCB. If this occurs three times, fault message F.752 appears.
S.581 Connection fault: Frequency converter not recognised	Missing communication between the frequency converter and the outdoor unit's PCB. After this occurs three times, fault message F.753 appears.
S.590 Fault: 4-port valve position not correct	The 4-port diverter valve does not move fully to the heating or cooling position.

G Maintenance messages

Code	Meaning	Cause	Remedy
M.23	Status external current anode	<ul style="list-style-type: none"> - External current anode not recognised 	<ul style="list-style-type: none"> - If required, check for a cable break
M.32	Building circuit: Waterpress. Low	<ul style="list-style-type: none"> - Pressure loss in the building circuit due to leakages or air pockets - Building circuit pressure sensor is defective 	<ul style="list-style-type: none"> - Check the building circuit for leaks, top up with heating water and purge - Check the plug contact on the PCB and on the wiring harness; check that the pressure sensor is working correctly and, if required, replace the pressure sensor
M.200	Building circuit : Brine pressure low	<ul style="list-style-type: none"> - Pressure loss in the building circuit due to leakages or air pockets - Building circuit pressure sensor is defective 	<ul style="list-style-type: none"> - Check the building circuit for leaks, top up with heating water and purge - Check the plug contact on the PCB and on the wiring harness; check that the pressure sensor is working correctly and, if required, replace the pressure sensor
M.201	Sensor fault: Cylinder temperature	<ul style="list-style-type: none"> - Cylinder temperature sensor defective 	<ul style="list-style-type: none"> - Check the plug contact on the PCB and on the wiring harness; check that the sensor is working correctly and, if required, replace the sensor
M.202	Sensor fault: System temperature	<ul style="list-style-type: none"> - System temperature sensor defective 	<ul style="list-style-type: none"> - Check the plug contact on the PCB and on the wiring harness; check that the sensor is working correctly and, if required, replace the sensor
M.203	Connection fault: Disp. not recognised	<ul style="list-style-type: none"> - Display defective - Display not connected 	<ul style="list-style-type: none"> - Check the quality of the plug contact on the PCB and on the wiring harness - Replace the display, if required

H Comfort protection mode

Code	Meaning	Description	Remedy
200	Sensor fault: Temp. air inlet	Still possible to operate with existing, functional outdoor temperature sensor	Replace the air inlet sensor

I Fault codes

In the event of faults which are caused by components in the refrigerant circuit, inform customer service.

Code	Meaning	Cause	Remedy
F.022	Building circuit: Water press. too low	<ul style="list-style-type: none"> - Pressure loss in the building circuit due to leakages or air pockets - Building circuit pressure sensor defective 	<ul style="list-style-type: none"> - Check the building circuit for leaks - Top up with water, purge - Check the quality of the plug contact on the PCB and on the wiring harness - Check that the pressure sensor is working correctly - Replace the pressure sensor
F.042	Fault: Coding resistor	<ul style="list-style-type: none"> - Coding resistor damaged or not set 	<ul style="list-style-type: none"> - Check that the coding resistor is positioned correctly and, if required, replace it.
F.073	Sensor fault: Building circ. water pressure	<ul style="list-style-type: none"> - The sensor is not connected or the sensor input has short-circuited 	<ul style="list-style-type: none"> - Check and, if required, replace the sensor - Replace the wiring harness
F.514	Sensor fault: Compr. inlet temp.	<ul style="list-style-type: none"> - The sensor is not connected or the sensor input has short-circuited 	<ul style="list-style-type: none"> - Check and, if required, replace the sensor - Replace the wiring harness
F.517	Sensor fault: Compr. outlet temp.	<ul style="list-style-type: none"> - The sensor is not connected or the sensor input has short-circuited 	<ul style="list-style-type: none"> - Check and, if required, replace the sensor - Replace the wiring harness
F.519	Sensor fault: Building circuit return temp.	<ul style="list-style-type: none"> - The sensor is not connected or the sensor input has short-circuited 	<ul style="list-style-type: none"> - Check and, if required, replace the sensor - Replace the wiring harness
F.520	Sensor fault: Building circuit flow temp.	<ul style="list-style-type: none"> - The sensor is not connected or the sensor input has short-circuited 	<ul style="list-style-type: none"> - Check and, if required, replace the sensor - Replace the wiring harness
F.526	Sensor fault: EEV outlet temp.	<ul style="list-style-type: none"> - The sensor is not connected or the sensor input has short-circuited 	<ul style="list-style-type: none"> - Check and, if required, replace the sensor - Replace the wiring harness
F.546	Sensor fault: High pressure	<ul style="list-style-type: none"> - Sensor not connected or sensor input has short-circuited 	<ul style="list-style-type: none"> - Check the sensor (e.g. using an installation aid), and replace if necessary - Replace the wiring harness
F.582	Fault: EEV	<ul style="list-style-type: none"> - EEV is not connected correctly or there is a cable break to the coil 	<ul style="list-style-type: none"> - Check the plug connections and, if required, replace the coil from the EEV
F.585	Sensor fault: Capac. outlet temp.	<ul style="list-style-type: none"> - The sensor is not connected or the sensor input has short-circuited 	<ul style="list-style-type: none"> - Check and, if required, replace the sensor - Replace the wiring harness
F.718	Fan unit 1: Fan blocked	<ul style="list-style-type: none"> - There is no confirmation signal stating that the fan is rotating 	<ul style="list-style-type: none"> - Check the air route and, if required, remove any blockages
F.729	Compressor outlet temperature too low	<ul style="list-style-type: none"> - The compressor outlet temperature is lower than 0 °C for more than 10 minutes or the compressor outlet temperature is lower than -10 °C even though the heat pump is in the operating characteristics. 	<ul style="list-style-type: none"> - Checking the high-pressure sensor - Checking that the EEV is working correctly - Check the condenser outlet temperature sensor (subcooling) - Check whether the 4-port diverter valve is in the intermediate position - Checking the refrigerant volume for overfilling

Code	Meaning	Cause	Remedy
F.731	High-pressure switch open	<ul style="list-style-type: none"> - Refrigerant pressure too high. The integrated high-pressure switch in the outdoor unit has tripped at 41.5 bar (g) or 42.5 bar (abs) - Insufficient energy output via the condenser 	<ul style="list-style-type: none"> - Purging the building circuit - Too low a volume flow as a result of closing single room controls in an underfloor heating system - Check that the dirt filter that is in place is permeable - Refrigerant flow rate too low (e.g. electronic expansion valve defective, 4-port diverter valve is mechanically blocked, filter is blocked). Inform customer service. - Cooling mode: Check the fan unit for dirt - Check the high-pressure switch and high-pressure sensor - Reset the high-pressure switch and carry out a manual reset on the product.
F.732	Compressor outlet temperature too high	<p>The compressor outlet temperature is above 130 °C:</p> <ul style="list-style-type: none"> - Application limits exceeded - EEV does not work or does not open correctly - Refrigerant volume too low (frequent defrosting due to extremely low evaporation temperatures) 	<ul style="list-style-type: none"> - Check the compressor inlet sensor and outlet sensor - Check the compressor outlet temperature sensor (TT135) - Check the EEV (does the EEV move to the limit stop? Use the sensor/actuator test) - Check the refrigerant volume (see Technical data) - Carry out a leak-tightness test - Check whether the service valves on the outdoor unit are open.
F.733	Evaporation temperature too low	<ul style="list-style-type: none"> - Insufficient air volume flow through the outdoor unit's heat exchanger (heating mode) leads to an insufficient energy input in the environment circuit (heating mode) or building circuit (cooling mode) - Refrigerant volume too low 	<ul style="list-style-type: none"> - If the building circuit contains thermostatic valves, check that they are suitable for cooling mode (check volume flow in cooling mode) - Check the fan unit for dirt - Check the EEV (does the EEV move to the limit stop? Use the sensor/actuator test) - Check the compressor inlet sensor - Check the refrigerant volume
F.734	Condensation temperature too low	<ul style="list-style-type: none"> - The temperature in the heating circuit is too low, outside of the operating characteristics - Refrigerant volume too low 	<ul style="list-style-type: none"> - Check the EEV (does the EEV move to the limit stop? Use the sensor/actuator test) - Check the compressor inlet sensor - Check the refrigerant filling volume (see technical data) - Check whether the 4-port diverter valve is in an intermediate position and is not correctly switched - Check the high-pressure sensor - Check the pressure sensor in the heating circuit
F.735	Evaporation temperature too high	<ul style="list-style-type: none"> - Temperature in the environment circuit (heating mode) or building circuit (cooling mode) too high for compressor operation - Feed-in of external heat into the environment circuit too high due to increased fan speed 	<ul style="list-style-type: none"> - Check the system temperatures - Check the refrigerant filling volume for overfilling - Check the EEV (does the EEV move to the limit stop? Use sensor/actuator test) - Check the sensor for the evaporation temperature (depending on the position of the 4-port diverter valve) - Check the volume flow in cooling mode - Check the air volume flow in heating mode

Code	Meaning	Cause	Remedy
F.737	Condensation temperature too high	<ul style="list-style-type: none"> - Temperature in the environment circuit (cooling mode) or building circuit (heating mode) too high for compressor operation - Feed-in of external heat into the building circuit - Refrigerant circuit overfilled - Insufficient flow rate in the building circuit 	<ul style="list-style-type: none"> - Reduce or stop the external heat that is entering - Check the back-up heater (heats up even though it is off in the sensor/actuator test?) - Check the EEV (does the EEV move to the limit stop? Use the sensor/actuator test) - Check the compressor outlet sensor, compressor outlet temperature sensor (TT135) and high-pressure sensor - Check the refrigerant filling volume for overfilling - Check whether the service valves on the outdoor unit are open. - Check the air volume flow in cooling mode for sufficient flow rate - Checking the heating pump - Check the building circuit flow rate
F.741	Building circuit: Return temp. too low	<ul style="list-style-type: none"> - During the de-icing, the return temperature falls below 13 °C 	<ul style="list-style-type: none"> - Ensure the minimum installation volume is maintained; if required, install a series return cylinder - The fault message is displayed until the return temperature increases to above 20 °C. - Activate the electric back-up heater in the product's control panel and in the system control in order to increase the return temperature. The compressor is blocked while the fault message is present.
F.752	Fault: Frequency converter	<ul style="list-style-type: none"> - Internal electronics fault on the inverter PCB - Mains voltage outside of 70 V–282 V 	<ul style="list-style-type: none"> - Check the integrity of the power supply cables and compressor connection cables The plugs must audibly click into place. - Check the cable - Check the mains voltage The mains voltage must be between 195 V and 253 V. - Check the phases - Replace the frequency converter, if required
F.753	Connection fault: Freq. conv. n.recogn.	<ul style="list-style-type: none"> - Missing communication between the frequency converter and the outdoor unit's control PCB 	<ul style="list-style-type: none"> - Check the integrity of the wiring harness and plug connection and, if required, replace them - Check the frequency converter by actuating the compressor safety relay - Read the assigned parameters for the frequency converter and check whether values are displayed
F.755	Fault: 4-port valve position not correct	<ul style="list-style-type: none"> - Incorrect position of the 4-port diverter valve. If, in heating mode, the flow temperature is lower than the return temperature in the building circuit. - The temperature sensor in the electronic expansion valve environment circuit displays an incorrect temperature. 	<ul style="list-style-type: none"> - Check the 4-port diverter valve (is an audible switching available? Use the sensor/actuator test) - Check that the coil is positioned correctly on the 4-port valve - Check the wiring harness and plug connections - Check the temperature sensor in the electronic expansion valve environment circuit
F.774	Sensor fault: Air inlet temp.	<ul style="list-style-type: none"> - The sensor is not connected or the sensor input has short-circuited 	<ul style="list-style-type: none"> - Check and, if required, replace the sensor - Replace the wiring harness
F.785	Fan unit 2: Fan blocked	<ul style="list-style-type: none"> - There is no confirmation signal stating that the fan is rotating 	<ul style="list-style-type: none"> - Check the air route and, if required, remove any blockages

Code	Meaning	Cause	Remedy
F.788	Building circuit: Pump fault	<ul style="list-style-type: none"> - The electronics system of the high-efficiency pump has detected a fault (e.g. dry running, blockage, overvoltage, undervoltage) and has switched off and locked the pump. 	<ul style="list-style-type: none"> - Switch the heat pump off for at least 30 seconds (no current) - Check the quality of the plug contact on the PCB - Check that the pump functions correctly - Purging the building circuit - Check that the dirt filter that is in place is permeable
F.817	Freq. converter fault: Compressor	<ul style="list-style-type: none"> - Defect in the compressor (e.g. short circuit) - Defect in the frequency converter - Connection cable to the compressor is defective or loose 	<ul style="list-style-type: none"> - Measure the winding resistance in the compressor - Measure the frequency converter output between the three phases, (it must be > 1 kΩ) - Check the wiring harness and plug connections
F.818	Freq. converter fault: Mains voltage	<ul style="list-style-type: none"> - Incorrect mains voltage for operating the frequency converter - Shutdown via the energy supply company 	<ul style="list-style-type: none"> - Measure and, if required, correct the mains voltage <p>The mains voltage must be between 195 V and 253 V.</p>
F.819	Freq. converter fault: Overheating	<ul style="list-style-type: none"> - Internal overheating of the frequency converter 	<ul style="list-style-type: none"> - Allow the frequency converter to cool and restart the product - Check the frequency converter's air route - Check that the fan is working correctly - The maximum environmental temperature of the outdoor unit (46 °C) has been exceeded.
F.820	Connection fault: Building circuit pump	<ul style="list-style-type: none"> - Pump does not report any signal back to the heat pump 	<ul style="list-style-type: none"> - Check the cable to the pump for defects and, if required, replace it - Replace the pump
F.821	Sensor fault: Immers. heater flow temp.	<ul style="list-style-type: none"> - The sensor is not connected or the sensor input has short-circuited - Both of the flow temperature sensors in the heat pump are defective 	<ul style="list-style-type: none"> - Check and, if required, replace the sensor - Replace the wiring harness
F.823	Hot gas temperature switch open	<ul style="list-style-type: none"> - The hot gas thermostat shuts down the heat pump if the temperature in the refrigerant circuit is too high. Following a waiting period, the heat pump attempts to start once more. After three failed start attempts in succession, a fault message is displayed. - Max. refrigerant circuit temperature: 130 °C - Waiting period: 5 mins (after it first occurs) - Waiting period: 30 mins (after it occurs a second time and any other time after that) - The fault counter is reset if both of the following conditions are met: <ul style="list-style-type: none"> - Heat requirement without switching off prematurely - 60 mins uninterrupted operation 	<ul style="list-style-type: none"> - Check the EEV - Replace the dirt filter in the refrigeration circuit, if required
F.825	Sensor fault: Capac. inlet temp.	<ul style="list-style-type: none"> - Refrigerant circuit temperature sensor (vapour-forming) not connected or the sensor input has short-circuited 	<ul style="list-style-type: none"> - Check and, if required, replace the sensor and cable

Code	Meaning	Cause	Remedy
F.1100	Immersion heater: Safety cut-out open	<p>The safety cut-out on the electric back-up heater is open due to:</p> <ul style="list-style-type: none"> – Insufficient volume flow or air in the building circuit – The immersion heater is operated when the building circuit is not filled – Immersion heater operation at flow temperatures above 95 °C trips the safety fuse of the safety cut-out and requires that the fuse be replaced – Feed-in of external heat into the building circuit 	<ul style="list-style-type: none"> – Check the circulation in the building circuit pump – If required, open the stopcocks – Replace the safety cut-out – Reduce or stop the external heat that is entering – Check that the dirt filter that is in place is permeable
F.1117	Compressor: Phase failure	<ul style="list-style-type: none"> – Defective fuse – Incorrect electrical connections – Mains voltage too low – Compressor/low tariff power supply not connected – Energy supply company lockout for longer than three hours 	<ul style="list-style-type: none"> – Check the fuse – Checking the electrical connections – Check the voltage at the heat pump electrical connection – Reduce energy supply company anti-cycling time to under three hours
F.1120	Immersion heater: Phase failure	<ul style="list-style-type: none"> – Electric back-up heater defective – Poorly tightened electrical connections – Mains voltage too low 	<ul style="list-style-type: none"> – Check the electric back-up heater and its power supply – Check the electrical connections – Measure the voltage at the electrical connection for the electric back-up heater
F.9998	Connection fault: Heat pump	<ul style="list-style-type: none"> – eBUS cable not connected or connected incorrectly – Outdoor unit without supply voltage 	<ul style="list-style-type: none"> – Check the connection pipes between the power supply PCB and control PCB on the indoor and outdoor unit

J 5.4 kW back-up heater

Applies for products with a heat output of 5 kW and 7 kW

Internal control of the output levels	Power consumption	Set value
0	0.0 kW	
1	0.9 kW	1 kW
2	1.1 kW	
3	1.7 kW	
4	2.0 kW	2 kW
5	2.8 kW	3 kW
6	3.7 kW	4 kW
7	4.5 kW	5 kW
8	5.4 kW	6 kW

K 8.54 kW back-up heater at 230 V

Applies for products with a heat output of 12 kW

Internal control of the output levels at 230 V	Power consumption	Set value
0	0.0 kW	
1	0.7 kW	1 kW
2	1.2 kW	
3	1.8 kW	2 kW
4	2.2 kW	3 kW
5	3.2 kW	
6	3.8 kW	4 kW
7	4.7 kW	5 kW

Internal control of the output levels at 230 V	Power consumption	Set value
8	5.4 kW	6 kW

L 8.54 kW back-up heater at 400 V

Applies for products with a heat output of 12 kW

Internal control of the output levels at 400 V	Power consumption	Set value
0	0.0 kW	
1	0.7 kW	1 kW
2	1.2 kW	
3	1.8 kW	2 kW
4	2.3 kW	
5	3.0 kW	3 kW
6	3.9 kW	4 kW
7	4.7 kW	5 kW
8	5.6 kW	6 kW
9	6.2 kW	
10	7.0 kW	7 kW
11	7.9 kW	8 kW
12	8.5 kW	9 kW

M Inspection and maintenance work

#	Maintenance work	Interval	
1	Checking the pre-charge pressure of the expansion vessel	Annually	44
2	Check that the prioritising diverter valve can move easily (visually/audibly)	Annually	
3	Checking the refrigerant circuit, removing rust and oil	Annually	
4	Checking the electronics boxes, removing dust from the ventilation slits	Annually	
5	Checking the vibration dampers on the refrigerant pipes	Annually	

N Characteristic values for the temperature sensor, refrigeration circuit

Temperature (°C)	Resistance (ohms)
-40	327344
-35	237193
-30	173657
-25	128410
-20	95862
-15	72222
-10	54892
-5	42073
0	32510
5	25316
10	19862
15	15694
20	12486
25	10000
30	8060
35	6535
40	5330
45	4372

Temperature (°C)	Resistance (ohms)
50	3605
55	2989
60	2490
65	2084
70	1753
75	1481
80	1256
85	1070
90	916
95	786
100	678
105	586
110	509
115	443
120	387
125	339
130	298
135	263
140	232
145	206
150	183
155	163

O Characteristic values for the internal temperature sensors, hydraulic circuit

Sensors: TT620 TT650

Temperature (°C)	Resistance (ohms)
0	33400
5	25902
10	20247
15	15950
20	12657
25	10115
30	8138
35	6589
40	5367
45	4398
50	3624
55	3002
60	2500
65	2092
70	1759
75	1486
80	1260
85	1074
90	918
95	788
100	680
105	588
110	510

P Characteristic values for the VR10 internal temperature sensors, cylinder temperature

Temperature (°C)	Resistance (ohms)
-40	88130
-35	64710
-30	47770
-25	35440
-20	26460
-15	19900
-10	15090
-5	11520
0	8870
5	6890
10	5390
15	4240
20	3375
25	2700
30	2172
35	1758
40	1432
45	1173
50	966
55	800
60	667
65	558
70	470
75	397
80	338
85	288
90	248
95	213
100	185
105	160
110	139
115	122
120	107
125	94
130	83
135	73
140	65
145	58
150	51

Q Characteristic values for the VRC DCF outdoor temperature sensor

Temperature (°C)	Resistance (ohms)
-25	2167
-20	2067
-15	1976
-10	1862
-5	1745
0	1619
5	1494
10	1387
15	1246
20	1128
25	1020
30	920
35	831
40	740

R Technical data



Note

The following performance data is only applicable to new products with clean heat exchangers.

Technical data – General

	VWL 57/5 IS	VWL 77/5 IS	VWL 127/5 IS
Product dimensions, width	440 mm	440 mm	440 mm
Product dimensions, height	720 mm	720 mm	720 mm
Product dimensions, depth	350 mm	350 mm	350 mm
Weight, without packaging	23 kg	24 kg	26.5 kg
Heating circuit connections	G 1"	G 1"	G 1"
Domestic hot water cylinder connections	G 1"	G 1"	G 1"

Technical data – Heating circuit

	VWL 57/5 IS	VWL 77/5 IS	VWL 127/5 IS
Material in the heating circuit	Copper, copper-zinc alloy, stainless steel, ethylene propylene diene monomer rubber, brass, steel, composite materials	Copper, copper-zinc alloy, stainless steel, ethylene propylene diene monomer rubber, brass, steel, composite materials	Copper, copper-zinc alloy, stainless steel, ethylene propylene diene monomer rubber, brass, steel, composite materials
Permissible water composition	Without frost or corrosion protection. Soften the heating water at water hardnesses from 3.0 mmol/l (16.8° dH) according to Directive VDI 2035 sheet 1.	Without frost or corrosion protection. Soften the heating water at water hardnesses from 3.0 mmol/l (16.8° dH) according to Directive VDI 2035 sheet 1.	Without frost or corrosion protection. Soften the heating water at water hardnesses from 3.0 mmol/l (16.8° dH) according to Directive VDI 2035 sheet 1.
Minimum operating pressure	0.05 MPa (0.50 bar)	0.05 MPa (0.50 bar)	0.05 MPa (0.50 bar)
Maximum operating pressure	0.3 MPa (3.0 bar)	0.3 MPa (3.0 bar)	0.3 MPa (3.0 bar)
Min. heating mode flow temperature	20 °C	20 °C	20 °C
Max. heating mode flow temperature with compressor	55 °C	55 °C	55 °C
Max. heating mode flow temperature with back-up heater	75 °C	75 °C	75 °C

	VWL 57/5 IS	VWL 77/5 IS	VWL 127/5 IS
Min. cooling mode flow temperature	7 °C	7 °C	7 °C
Max. flow temperature in cooling mode	25 °C	25 °C	25 °C
Min. nominal volume flow with 3kW outdoor unit	0.3 m³/h		
Min. nominal volume flow with 5kW outdoor unit	0.4 m³/h		
Minimum nominal volume flow rate		0.55 m³/h	
Min. nominal volume flow with 10 kW outdoor unit			1.13 m³/h
Min. nominal volume flow with 12 kW outdoor unit			1.18 m³/h
Nominal volume flow ΔT 5K with 3kW outdoor unit	0.54 m³/h		
Nominal volume flow ΔT 5K with 5kW outdoor unit	0.79 m³/h		
Nominal volume flow ΔT 5 K		1.02 m³/h	
Nominal volume flow ΔT 5 K with 10 kW outdoor unit			1.70 m³/h
Nominal volume flow ΔT 5 K with 12 kW outdoor unit			1.80 m³/h
Nominal volume flow ΔT 8K with 3kW outdoor unit	0.3 m³/h		
Nominal volume flow ΔT 8K with 5kW outdoor unit	0.4 m³/h		
Nominal volume flow ΔT 8 K		0.55 m³/h	
Nominal volume flow ΔT 8 K with 10 kW outdoor unit			1.13 m³/h
Nominal volume flow ΔT 8 K with 12 kW outdoor unit			1.18 m³/h
Remaining feed head ΔT 5K with 3kW outdoor unit	71 kPa (710 mbar)		
Remaining feed head ΔT 5K with 5kW outdoor unit	68 kPa (680 mbar)		
Remaining feed head ΔT 5 K		66 kPa (660 mbar)	
Remaining feed head ΔT 5 K with 10 kW outdoor unit			42 kPa (420 mbar)
Remaining feed head ΔT 5 K with 12 kW outdoor unit			38 kPa (380 mbar)
Remaining feed head ΔT 8K with 3kW outdoor unit	71 kPa (710 mbar)		
Remaining feed head ΔT 8K with 5kW outdoor unit	68 kPa (680 mbar)		
Remaining feed head ΔT 8 K		73 kPa (730 mbar)	
Remaining feed head ΔT 8 K with 10 kW outdoor unit			60 kPa (600 mbar)
Remaining feed head ΔT 8 K with 12 kW outdoor unit			68 kPa (680 mbar)
Min. volume flow during continuous operation at the application limits with a 3kW outdoor unit	0.3 m³/h		
Min. volume flow during continuous operation at the application limits with a 5kW outdoor unit	0.4 m³/h		
Min. volume flow during continuous operation at the application limits		0.55 m³/h	

	VWL 57/5 IS	VWL 77/5 IS	VWL 127/5 IS
Min. volume flow during continuous operation at the application limits with a 10 kW outdoor unit			1.13 m ³ /h
Min. volume flow during continuous operation at the application limits with a 12 kW outdoor unit			1.18 m ³ /h
Max. volume flow during continuous operation at the application limits with a 3kW outdoor unit	0.54 m ³ /h		
Max. volume flow during continuous operation at the application limits with a 5kW outdoor unit	0.79 m ³ /h		
Max. volume flow during continuous operation at the application limits		1.08 m ³ /h	
Max. volume flow during continuous operation at the application limits with a 10 kW outdoor unit			1.7 m ³ /h
Max. volume flow during continuous operation at the application limits with a 12 kW outdoor unit			1.8 m ³ /h
Pump type	High-efficiency pump	High-efficiency pump	High-efficiency pump
Energy efficiency index (EEI) of the pump	≤0.2	≤0.2	≤0.2

Technical data – Electrics

	VWL 57/5 IS	VWL 77/5 IS	VWL 127/5 IS
Rated voltage	230 V (+10%/-15%), 50 Hz, 1~/N/PE	230 V (+10%/-15%), 50 Hz, 1~/N/PE	230 V (+10%/-15%), 50 Hz, 1~/N/PE
Rated voltage	400 V (+10%/-15%), 50 Hz, 3~/N/PE	400 V (+10%/-15%), 50 Hz, 3~/N/PE	400 V (+10%/-15%), 50 Hz, 3~/N/PE
Rated power, maximum	5.4 kW	5.4 kW	8.8 kW
Rated current, maximum	23.3 A (230 V), 8.7 A (400 V)	23.3 A (230 V), 8.7 A (400 V)	23.5 A (230 V), 13.7 A (400 V)
IP rating	IP 10B	IP 10B	IP 10B
Overvoltage category	II	II	II
Fuse type, characteristic C, slow-blow, three-pole switching (disconnection of the three mains connection lines in one switching operation)	Design in accordance with the selected connection diagrams	Design in accordance with the selected connection diagrams	Design in accordance with the selected connection diagrams
Min. electrical power consumption of the heating pump	2 W	2 W	2 W
Max. electrical power consumption of the heating pump	60 W	60 W	90 W
Electrical power consumption of the heating pump at A7/W35 ΔT 5 K with an external pressure loss of 250 mbar in the heating circuit	20 W	20 W	80 W

Technical data – Refrigerant circuit

	VWL 57/5 IS	VWL 77/5 IS	VWL 127/5 IS
Material, refrigerant pipe	Copper	Copper	Copper
Connection technology, refrigerant pipe	Flare connection	Flare connection	Flare connection
Outer diameter, hot gas pipe	1/2" (12.7 mm)	5/8" (15.875 mm)	5/8" (15.875 mm)
Outer diameter, liquid pipe	1/4" (6.35 mm)	3/8" (9.575 mm)	3/8" (9.575 mm)
Minimum wall thickness, hot gas pipe	0.8 mm	0.95 mm	0.95 mm
Minimum wall thickness, liquid pipe	0.8 mm	0.8 mm	0.8 mm

	VWL 57/5 IS	VWL 77/5 IS	VWL 127/5 IS
Refrigerant, type	R410A	R410A	R410A
Refrigerant, Global Warming Potential (GWP)	2088	2088	2088

**Note**

All specific and required information for the split installation and components of the outdoor unit are included in the corresponding installation instructions for the outdoor unit, which is used in combination with the current indoor unit.

Benchmark Commissioning & Warranty Validation Service Record

It is a requirement that the heat pump is installed and commissioned to the manufacturers' instructions and the data fields on the commissioning checklist completed in full.

To instigate the warranty the heat pump needs to be registered with the manufacturer within one month of the installation. The warranty rests with the end-user (consumer), and they should be made aware it is ultimately their responsibility to register with the manufacturer, within the allotted time period.

It is essential that the heat pump is serviced in line with the manufacturers' recommendations, at least annually. This must be carried out by a competent, certified operative. The service details should be recorded on the Benchmark Service and Interim Heat Pump Work Record and left with the householder. Failure to comply with the manufacturers' servicing instructions and requirements will invalidate the warranty.



www.hhic.co.uk

This Commissioning Checklist is to be completed in full by the competent person who commissioned the heat pump and associated equipment as a means of demonstrating compliance with the appropriate Building Regulations and then handed to the customer to keep for future reference.

Failure to install and commission according to the manufacturers' instructions and complete this Benchmark Commissioning Checklist will invalidate the warranty. This does not affect the customer's statutory rights.

* All installations in England and Wales must be notified to Local Authority Building Control (LABC) either directly or through a Competent Persons Scheme. A Building Regulations Compliance Certificate will then be issued to the customer.

© Heating and Hotwater Industry Council (HHIC)



www.hhic.org.uk
Issue date: 20.08.2020

AIR TO WATER HEAT PUMP COMMISSIONING CHECKLIST

This Commissioning Checklist is to be completed in full by the competent person who commissioned the heat pump and associated equipment as a means of demonstrating compliance with the appropriate Building Regulations and then handed to the customer to keep for future reference.

Failure to install and commission this equipment to the manufacturer's instructions may invalidate the warranty but does not affect statutory rights.

Customer name:	Telephone number:
Address:	
Heat Pump Make and Model	
Heat Pump Serial Number	
Commissioned by (PRINT NAME):	Certified Operative Reg. No. [1]
Company name:	Telephone number:
Company address:	
	Commissioning date:
Building Regulations Notification Number (if applicable) [2]	

CONTROLS - SYSTEM AND HEAT PUMP (tick the appropriate boxes)			
Time and temperature control to heating	Room thermostat and programmer/timer		Programmable Roomstat
	Load/weather compensation		Optimum start control
Time and temperature control to hot water	Cylinder thermostat and programmer/timer		Combined with Heat pump main controls
Heating zone valves (including underfloor loops)	Fitted		Not required
Hot water zone valves	Fitted		Not required
Thermostatic radiator valves	Fitted		Not required
Heat Pump Safety Interlock [3]	Built In		Provided
Outdoor Sensor	Fitted		Not required
Automatic bypass to system	Fitted		Not required
Buffer Vessel Fitted	Yes	No	If YES Volume: Litres

ALL SYSTEMS	
The heating system has been filled and pressure tested	Yes
Expansion vessel for heating is sized, fitted & charged in accordance with manufacturer's instructions	Yes
The heat pump is fitted on a solid/stable surface capable of taking its weight	Yes
The system has been flushed and cleaned in accordance with BS7593 and heat pump manufacturer's instructions	Yes
What system cleaner was used?	
What inhibitor was used?	Quantity litres
Is the system adequately frost protected?	Yes

OUTDOOR UNIT	
Are all external pipeworks insulated?	Yes
Is the fan free from obstacles and operational?	Yes
Has suitable consideration been made for waste water discharge?	Yes

CENTRAL HEATING MODE	
Heating Flow Temperature	°C Heating Return Temperature °C

DOMESTIC HOT WATER MODE Measure and Record:			
Is the heat pump connected to a hot water cylinder?	Unvented	Vented	Thermal Store Not Connected
Hot water has been checked at all outlets	Yes	Have Thermostatic Blending Valves been fitted?	Yes Not required

ADDITIONAL SYSTEM INFORMATON					
Additional heat sources connected:	Gas Boiler	Oil Boiler	Electric Heater	Solar Thermal	Other:

ALL INSTALLATIONS	
The heating, hot water and ventilation systems complies with the appropriate Building Regulations	Yes
All electrical work complies with the appropriate Regulations	Yes
The heat pump and associated products have been installed and commissioned in accordance with the manufacturer's instructions	Yes
The operation of the heat pump and system controls have been demonstrated to the customer	Yes
The manufacturer's literature, including Benchmark Checklist and Service Record, has been explained and left with the customer	Yes

Commissioning Engineer's Signature
Customer's Signature
(To confirm satisfactory demonstration and receipt of manufacturer's literature)

Notes: [1] Installers should be members of an appropriate Competent Persons Scheme. [2] All installations in England and Wales must be notified to Local Area Building Control (LABC) either directly or through a Competent Persons Scheme. A Building Regulations Compliance Certificate will then be issued to the customer. [3] May be required for systems covered by G3 Regulations



SERVICE RECORD

It is recommended that your heating system is serviced regularly and that the appropriate Service Interval Record is completed.

Service Provider

Before completing the appropriate Service Record below, please ensure you have carried out the service as described in the manufacturer's instructions. Always use the manufacturer's specified spare part when replacing controls.

SERVICE 01	Date:	SERVICE 02	Date:
Engineer name:		Engineer name:	
Company name:		Company name:	
Telephone No:		Telephone No:	
Operative ID No:		Operative ID No:	
Comments:		Comments:	
Signature		Signature	
SERVICE 03	Date:	SERVICE 04	Date:
Engineer name:		Engineer name:	
Company name:		Company name:	
Telephone No:		Telephone No:	
Operative ID No:		Operative ID No:	
Comments:		Comments:	
Signature		Signature	
SERVICE 05	Date:	SERVICE 06	Date:
Engineer name:		Engineer name:	
Company name:		Company name:	
Telephone No:		Telephone No:	
Operative ID No:		Operative ID No:	
Comments:		Comments:	
Signature		Signature	
SERVICE 07	Date:	SERVICE 08	Date:
Engineer name:		Engineer name:	
Company name:		Company name:	
Telephone No:		Telephone No:	
Operative ID No:		Operative ID No:	
Comments:		Comments:	
Signature		Signature	
SERVICE 09	Date:	SERVICE 10	Date:
Engineer name:		Engineer name:	
Company name:		Company name:	
Telephone No:		Telephone No:	
Operative ID No:		Operative ID No:	
Comments:		Comments:	
Signature		Signature	

Index

A		
Actuator test	42	
Article number	23	
B		
Back-up heater	33	
Basic diagram	18	
C		
Cable duct, in the product	30	
Calling up, code layer	39	
Calling up, installer level	39	
Calling up, statistics	39	
CE marking	24	
Check programmes		
Use	42	
Checking, electrical installation	35	
Checking, filling pressure, heating installation	44	
Checking, high-pressure switch-off	44	
Checking, maintenance message	43	
Checking, service message	43	
Circulation pump, connecting	34	
Code layer, calling up	39	
Comfort protection mode	43	
Competent person	18	
Component test	42	
Cooling mode, activating	40	
Cylinder connection	28	
D		
Data plate	23	
Disposal, accessories	45	
Disposal, packaging	45	
Disposal, product	45	
Disposing of the packaging	45	
Domestic hot water temperature	19	
E		
Electric back-up heater	39	
Electrical installation, checking	35	
Electricity	18	
Expansion relief valve	29	
F		
Fault codes	42	
Fault memory	42	
Fault symbol	42	
Filling and purging	37	
Filling pressure		
Display	40	
Filling pressure, checking, heating installation	44	
Flow temperature, setting, heating mode	41	
Frost	19	
Frost protection function	21	
Function menu	42	
Functionality	22	
H		
Heat pump system	21	
Heating circuit connections	29	
High-pressure switch-off	44	
Hot gas thermostat	21	
I		
Inspection	43	
Inspection work	43	
Installation assistant	38	
Restart	39	
Installation assistant, ending	38	
Installation clearances	26	
Installer level, calling up	39	
Intended use	18	
L		
Live Monitor	41	
Low-water pressure protection	21	
M		
Maintenance	43	
Maintenance message, checking	43	
Maintenance work	43	
Minimum clearances	26	
O		
Operating concept	35	
Operating mode	41	
P		
Parameters		
Reset	42	
Power supply	30	
Pre-charge pressure of expansion vessel	44	
Preparing		
Repair	42	
Pump blocking protection	21	
Q		
Qualification	18	
R		
Refrigerant	19	
Regulations	20	
Remaining feed head of the product	41	
Repair		
Preparing	42	
Reset	42	
Resetting		
All parameters	42	
Risk of scalding	19	
S		
Safety cut-out	21	
Safety device	18	
Screed-drying function		
Activating the screed-drying function	39	
Self-test	42	
Sensor test	42	
Serial number	23	
Service message, checking	43	
Service partner	41	
Setting, flow temperature, heating mode	41	
Spare parts	43	
Starting		
Installation assistant	39	
Statistics, calling up	39	
Status codes	41	
Switching on	38	
T		
Test menu	42	
Test operation	44	
Tool	19	
Transport	19	
Treating the heating water	36	
U		
Unit configuration		
Checking	39	
Use		
Check programmes	42	
V		
Voltage	18	

W	
Weight	26
Wiring	34

Supplier

Vaillant Ltd.

Nottingham Road ■ Belper ■ Derbyshire ■ DE56 1JT

Telephone 0330 100 3143

info@vaillant.co.uk ■ www.vaillant.co.uk



0020257319_05

Publisher/manufacturer

Vaillant GmbH

Berghauser Str. 40 ■ D-42859 Remscheid

Tel. +49 2191 18 0 ■ Fax +49 2191 18 2810

info@vaillant.de ■ www.vaillant.de

© These instructions, or parts thereof, are protected by copyright and may be reproduced or distributed only with the manufacturer's written consent.

Subject to technical modifications.