

MINIMUM  
CLEARANCE TOP  
80/125 FLUE

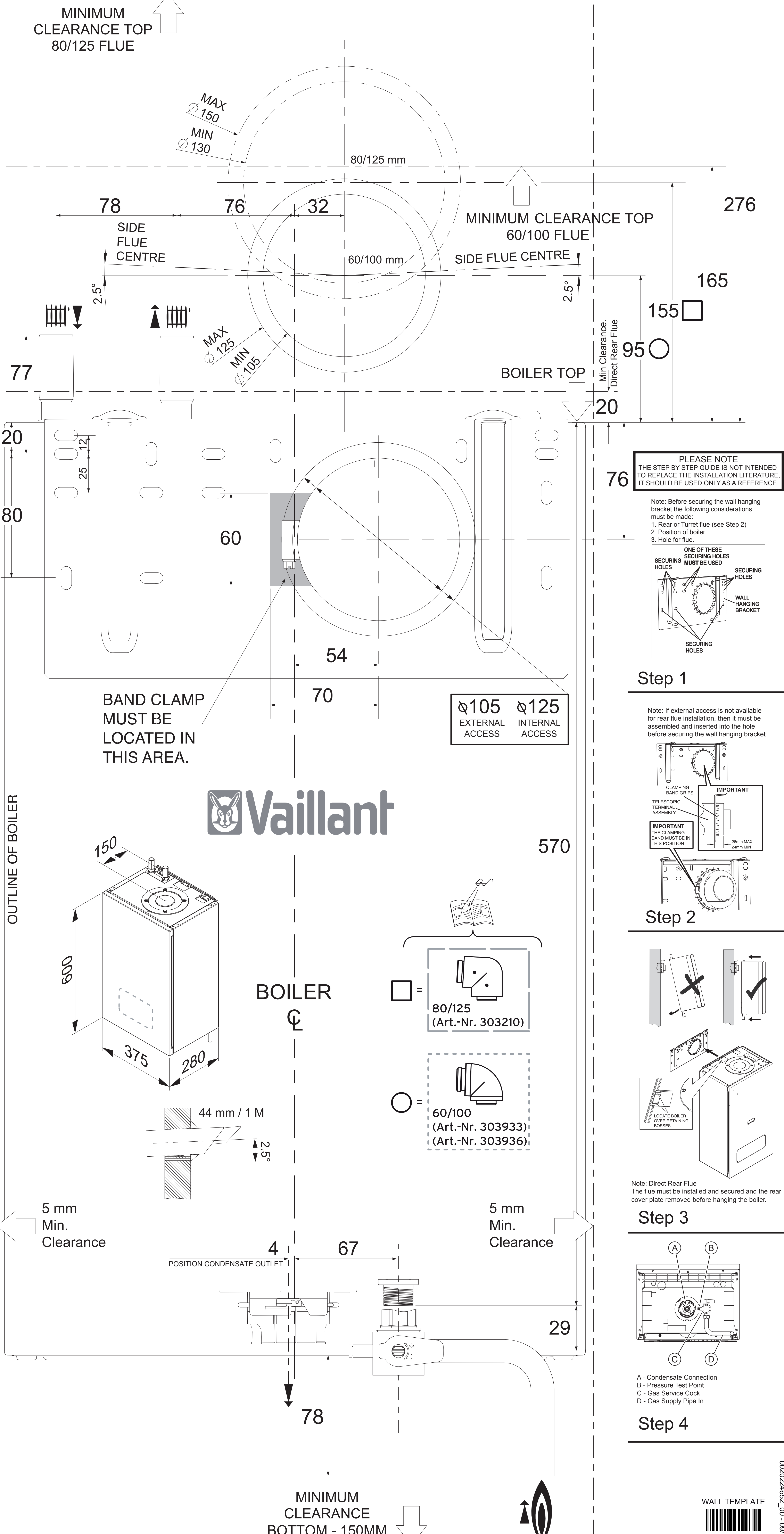

**PLEASE NOTE**  
THE STEP BY STEP GUIDE IS NOT INTENDED TO REPLACE THE INSTALLATION LITERATURE. IT SHOULD BE USED ONLY AS A REFERENCE.

- Note: Before securing the wall hanging bracket the following considerations must be made:
1. Rear or Turret flue (see Step 2)
  2. Position of boiler
  3. Hole for flue.

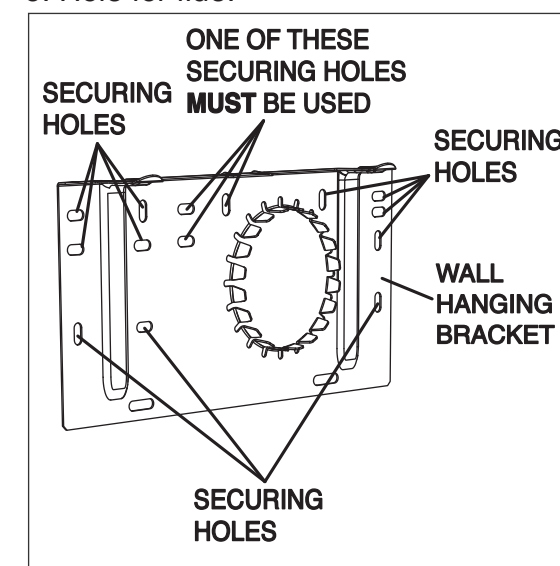

**Step 1**

Note: If external access is not available for rear flue installation, then it must be assembled and inserted into the hole before securing the wall hanging bracket.

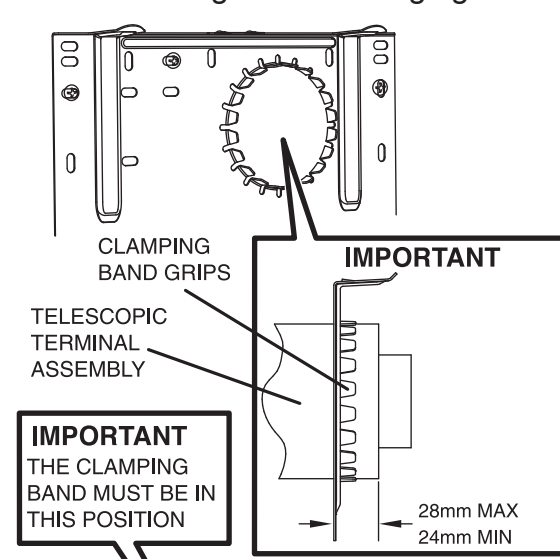

**Step 2**

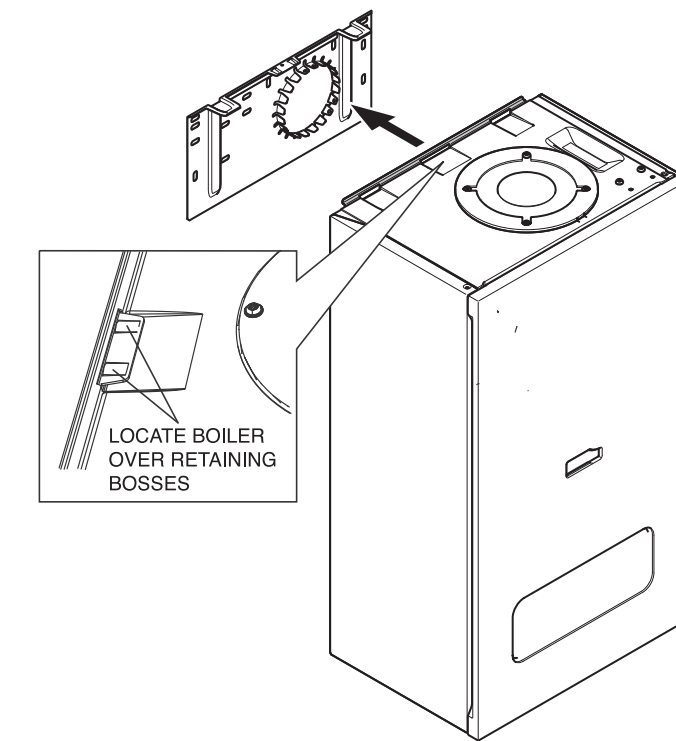
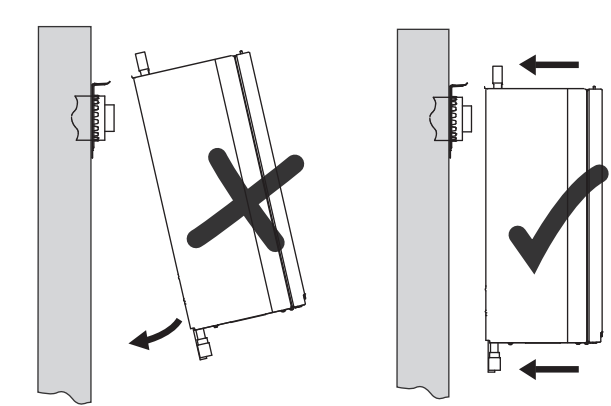

Note: Direct Rear Flue  
The flue must be installed and secured and the rear cover plate removed before hanging the boiler.

**Step 3**

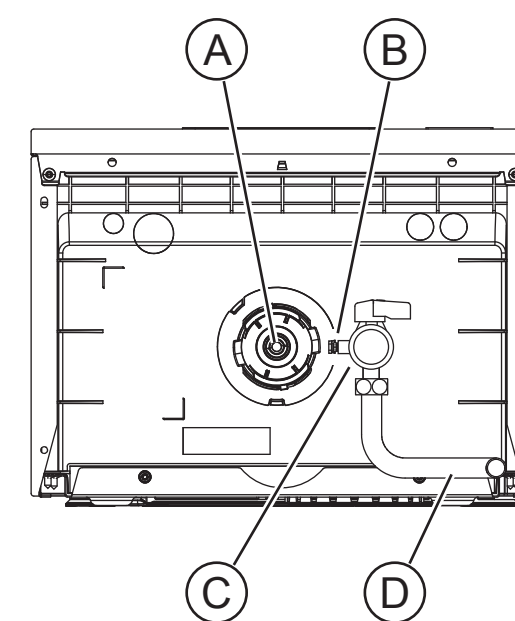

**Step 4**

WALL TEMPLATE

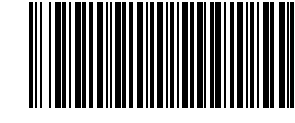

0020224652