

## Installation and maintenance instructions



ecoTEC plus

VU 246/6-5 OVZ (P-GB)

**GB, IE**

**Publisher/manufacturer**

**Vaillant GmbH**

Berghauser Str. 40 ■ D-42859 Remscheid  
Tel. +492191 18 0 ■ Fax +492191 18 2810  
info@vaillant.de ■ www.vaillant.de



# Contents

## Contents

|          |   |           |                       |   |           |
|----------|---|-----------|-----------------------|---|-----------|
| <b>1</b> | <b>Safety</b> .....   | <b>3</b>  | 7.8                   | Switching on the product .....                                    | 18        |
| 1.1      | Action-related warnings .....   | 3         | 7.9                   | Filling the heating installation .....                            | 18        |
| 1.2      | Intended use .....  | 3         | 7.10                  | Checking the gas flow rate .....                                  | 18        |
| 1.3      | General safety information .....  | 3         | 7.11                  | Checking and adjusting the gas settings .....                     | 18        |
| 1.4      | Regulations (directives, laws, standards) .....                               | 5         | 7.12                  | Checking leak-tightness .....                                     | 19        |
| <b>2</b> | <b>Notes on the documentation</b> .....                                       | <b>6</b>  | 7.13                  | Checking the heating mode .....                                   | 19        |
| 2.1      | Observing other applicable documents .....                                    | 6         | <b>8</b>              | <b>Adapting the unit to the heating installation</b> .....        | <b>20</b> |
| 2.2      | Storing documents .....   | 6         | 8.1                   | Burner anti-cycling time .....                                    | 20        |
| 2.3      | Validity of the instructions .....  | 6         | <b>9</b>              | <b>Handing the product over to the end user</b> .....             | <b>20</b> |
| <b>3</b> | <b>Product description</b> .....  | <b>6</b>  | <b>10</b>             | <b>Troubleshooting</b> .....                                      | <b>20</b> |
| 3.1      | Benchmark .....   | 6         | 10.1                  | Rectifying faults .....   | 20        |
| 3.2      | Compartment Ventilation .....   | 6         | 10.2                  | Procuring spare parts .....                                       | 20        |
| 3.3      | Serial number .....   | 6         | 10.3                  | Calling up the fault memory .....                                 | 21        |
| 3.4      | Information on the identification plate .....                                 | 6         | 10.4                  | Deleting the fault memory .....                                   | 21        |
| 3.5      | CE label .....  | 7         | 10.5                  | Preparing the repair work .....                                   | 21        |
| 3.6      | Functional elements .....   | 7         | 10.6                  | Replacing defective components .....                              | 21        |
| <b>4</b> | <b>Set-up</b> .....   | <b>7</b>  | 10.7                  | Checking the product for leak-tightness .....                     | 22        |
| 4.1      | Transporting the unit .....   | 7         | <b>11</b>             | <b>Inspection and maintenance</b> .....                           | <b>22</b> |
| 4.2      | Unpacking the product .....   | 7         | 11.1                  | Using original seals .....  | 22        |
| 4.3      | Checking the scope of delivery .....  | 7         | 11.2                  | Observing inspection and maintenance intervals .....              | 22        |
| 4.4      | Dimensions .....  | 8         | 11.3                  | Checking the CO <sub>2</sub> content .....                        | 22        |
| 4.5      | Minimum clearances .....  | 8         | 11.4                  | Setting the CO <sub>2</sub> content .....                         | 23        |
| 4.6      | Clearance from combustible components .....                                   | 8         | 11.5                  | Removing the gas-air mixture unit .....                           | 23        |
| 4.7      | Using the mounting template .....   | 8         | 11.6                  | Cleaning the heat exchanger .....                                 | 24        |
| 4.8      | Wall-mounting the product .....   | 8         | 11.7                  | Checking the burner .....   | 24        |
| 4.9      | Removing/installing the front casing .....                                    | 9         | 11.8                  | Checking the ignition electrode .....                             | 24        |
| 4.10     | Removing/installing the side section .....                                    | 9         | 11.9                  | Cleaning the condensate trap .....                                | 25        |
| <b>5</b> | <b>Installation</b> .....   | <b>9</b>  | 11.10                 | Installing the gas-air mixture unit .....                         | 25        |
| 5.1      | Preparing for installation .....  | 9         | 11.11                 | Draining the product .....  | 25        |
| 5.2      | Installing the heating pump .....   | 10        | 11.12                 | Completing inspection and maintenance work .....                  | 25        |
| 5.3      | Heating water supply in the open heating system .....                         | 11        | 11.13                 | Checking the product for leak-tightness .....                     | 25        |
| 5.4      | Purging the liquid gas tank .....   | 11        | <b>12</b>             | <b>Decommissioning the product</b> .....                          | <b>25</b> |
| 5.5      | Using the correct gas type .....  | 11        | <b>13</b>             | <b>Recycling and disposal</b> .....                               | <b>25</b> |
| 5.6      | Connecting the heating flow and heating return .....                          | 11        | <b>14</b>             | <b>Customer service</b> .....                                     | <b>25</b> |
| 5.7      | Gas connection .....  | 11        | <b>Appendix</b> ..... | <b>26</b>   |           |
| 5.8      | Connecting the condensate discharge pipe .....                                | 12        | <b>A</b>              | <b>Inspection and maintenance work</b> .....                      | <b>26</b> |
| 5.9      | Electrical installation .....   | 13        | <b>B</b>              | <b>Installer level – Overview</b> .....                           | <b>27</b> |
| <b>6</b> | <b>Operation</b> .....  | <b>15</b> | <b>C</b>              | <b>Overview of diagnostics codes</b> .....                        | <b>29</b> |
| 6.1      | Operating concept .....   | 15        | <b>D</b>              | <b>Status codes – Overview</b> .....                              | <b>32</b> |
| 6.2      | Calling up the installer level .....  | 15        | <b>E</b>              | <b>Overview of fault codes</b> .....                              | <b>33</b> |
| 6.3      | Live Monitor (status codes) .....   | 15        | <b>F</b>              | <b>Wiring diagram</b> .....                                       | <b>35</b> |
| <b>7</b> | <b>Start-up</b> .....   | <b>15</b> | <b>G</b>              | <b>Position of the opening in the air/flue pipe</b> .....         | <b>36</b> |
| 7.1      | Carrying out the initial start-up .....                                       | 15        | G.1                   | Positioning of the opening of a fan-supported flue gas pipe ..... | 36        |
| 7.2      | Running the installation assistants .....                                     | 15        | G.2                   | Horizontal terminal positioning .....                             | 37        |
| 7.3      | Restarting the installation assistants .....                                  | 16        | <b>H</b>              | <b>Commissioning Checklist</b> .....                              | <b>38</b> |
| 7.4      | Test programmes .....   | 16        | <b>I</b>              | <b>Technical data</b> .....                                       | <b>42</b> |
| 7.5      | Checking the factory setting .....  | 16        | <b>Index</b> .....    | <b>44</b>   |           |
| 7.6      | Checking and treating the heating water/filling and supplementary water ..... | 16        |                       |   |           |
| 7.7      | Filling the condensate trap .....   | 18        |                       |   |           |



## 1 Safety

### 1.1 Action-related warnings

#### Classification of action-related warnings

The action-related warnings are classified in accordance with the severity of the possible danger using the following warning signs and signal words:

#### Warning symbols and signal words



#### **Danger!**

Imminent danger to life or risk of severe personal injury



#### **Danger!**

Risk of death from electric shock



#### **Warning.**

Risk of minor personal injury



#### **Caution.**

Risk of material or environmental damage

### 1.2 Intended use

There is a risk of injury or death to the user or others, or of damage to the product and other property in the event of improper use or use for which it is not intended.

The product is intended as a heat generator for closed heating installations and for hot water generation.

Depending on the unit type, the products referred to in these instructions must only be installed and operated in conjunction with the air/flue pipe accessories listed in the other applicable documents.

The use of the product in vehicles, such as mobile homes and caravans, is not classed as intended use. Units that are not classed as vehicles are those that are installed in a fixed and permanent location (known as "fixed installation").

Intended use includes the following:

- observance of accompanying operating, installation and servicing instructions for the product and any other system components
- installing and fitting the product in accordance with the product and system approval

- compliance with all inspection and maintenance conditions listed in the instructions.

Intended use also covers installation in accordance with the IP code.

Any other use that is not specified in these instructions, or use beyond that specified in this document shall be considered improper use. Any direct use in industrial or commercial processes is also deemed to be improper.

#### **Caution.**

Improper use of any kind is prohibited.

### 1.3 General safety information

#### 1.3.1 Risk caused by inadequate qualifications

The following work must only be carried out by competent persons who are sufficiently qualified to do so:

- Set-up
- Dismantling
- Installation
- Start-up
- Inspection and maintenance
- Repair
- Decommissioning
- ▶ Proceed in accordance with current technology.

#### 1.3.2 Risk of death from escaping gas

What to do if you smell gas in the building:

- ▶ Avoid rooms that smell of gas.
- ▶ If possible, open doors and windows fully and ensure adequate ventilation.
- ▶ Do not use naked flames (e.g. lighters, matches).
- ▶ Do not smoke.
- ▶ Do not use any electrical switches, mains plugs, doorbells, telephones or other communication systems in the building.
- ▶ If it is safe to do so, close the emergency control valve or the main isolator.
- ▶ If possible, close the gas isolator cock on the product.
- ▶ Warn other occupants in the building by yelling or banging on doors or walls.



## 1 Safety



- ▶ Leave the building immediately and ensure that others do not enter the building.
- ▶ Notify the gas supply company or the National Grid +44 (0) 800 111999 by telephone once you are outside of the building.

### 1.3.3 Risk of death from escaping flue gas

If you operate the product with an empty condensate trap / siphon, then flue gas may escape into the room air.

- ▶ In order to operate the product, ensure that the condensate trap / siphon is always full.

### 1.3.4 Risk of death due to blocked or leaking flue gas routes

Installation errors, damage, tampering, unauthorised installation sites or similar can cause flue gas to escape and result in a risk of poisoning.

What to do if you smell flue gas in the property:

- ▶ Open all accessible doors and windows fully to provide ventilation.
- ▶ Switch off the product.
- ▶ Check the flue gas routes in the product and the flue gas diversions.

### 1.3.5 Risk of death from leaks if the product is installed below ground level

Liquid gas accumulates at floor level. If the product is installed below ground level, liquid gas may accumulate at floor level if there are any leaks. In this case, there is a risk of explosion.

- ▶ Make sure that liquid gas cannot escape from the product or the gas line under any circumstance.

### 1.3.6 Risk of poisoning and burns caused by escaping hot flue gases

- ▶ Only operate the product if the air/flue pipe has been completely installed.
- ▶ With the exception of short periods for testing purposes, only operate the product when the front casing is installed and closed.

### 1.3.7 Risk of death due to explosive and flammable materials

- ▶ Do not use the product in storage rooms that contain explosive or flammable substances (such as petrol, paper or paint).

### 1.3.8 Risk of death from electric shock

There is a risk of death from electric shock if you touch live components.

Before commencing work on the product:

- ▶ Disconnect the product from the power supply by switching off all power supplies at all poles (electrical partition with a contact gap of at least 3 mm, e.g. fuse or circuit breaker).
- ▶ Secure against being switched back on again.
- ▶ Wait for at least 3 minutes until the capacitors have discharged.
- ▶ Check that there is no voltage.

### 1.3.9 Risk of death due to lack of safety devices

The schematic drawings included in this document do not show all safety devices required for correct installation.

- ▶ Install the necessary safety devices in the system.
- ▶ Observe the applicable national and international laws, standards and guidelines.

### 1.3.10 Risk of injury due to the heavy weight of the product

- ▶ Make sure that the product is transported by at least two people.

### 1.3.11 Risk of death due to cabinet-type casing

Cabinet-type casing can give rise to dangerous situations when used on a product which is operated with an open flue.

- ▶ Ensure that the product is supplied with sufficient combustion air.

### 1.3.12 Risk of corrosion damage due to unsuitable combustion and room air

Sprays, solvents, chlorinated cleaning agents, paint, adhesives, ammonia compounds, dust or similar substances may lead





to corrosion on the product and in the flue system.

- ▶ Ensure that the supply of combustion air is always free of fluorine, chlorine, sulphur, dust, etc.
- ▶ Ensure that no chemical substances are stored at the installation site.
- ▶ If you are installing the product in hairdressing salons, painter's or joiner's workshops, cleaning businesses or similar locations, choose a separate installation room in which the room air is technically free of chemical substances.

#### **1.3.13 Risk of material damage caused by frost**

- ▶ Do not install the product in rooms prone to frost.

#### **1.3.14 Risk of being burned or scalded by hot components**

- ▶ Only carry out work on these components once they have cooled down.

#### **1.3.15 Risk of material damage caused by using an unsuitable tool**

- ▶ Use the correct tool.

### **1.4 Regulations (directives, laws, standards)**

- ▶ Observe the national regulations, standards, directives, ordinances and laws.



## 2 Notes on the documentation

### 2 Notes on the documentation

#### 2.1 Observing other applicable documents

- ▶ You must observe all the operating and installation instructions included with the system components.

#### 2.2 Storing documents

- ▶ Pass these instructions and all other applicable documents on to the system operator.

#### 2.3 Validity of the instructions

These instructions apply only to:

##### Product article number

|  | Article number | Gas Council Number |
|--|----------------|--------------------|
| VU 246/6-5 OVZ (P-GB)<br>ecoTEC plus 424 P | 0010021225     | 41-694-18          |

## 3 Product description

### 3.1 Benchmark

Vaillant is a licensed member of the Benchmark Scheme.

Benchmark places responsibilities on both manufacturers and installers. The purpose is to ensure that customers are provided with the correct equipment for their needs, that it is installed, commissioned and serviced in accordance with the manufacturer's instructions by a competent person approved at the time by the Health and Safety Executive and that it meets the requirements of the appropriate Building Regulations. The Benchmark Checklist can be used to demonstrate compliance with Building Regulations and should be provided to the customer for future reference.

Installers are required to carry out installation, commissioning and servicing work in accordance with the Benchmark Code of Practice which is available from the Heating and Hotwater Industry Council who manage and promote the Scheme.

Benchmark is managed and promoted by the Heating and Hotwater Industry Council.



For more information visit [www.centralheating.co.uk](http://www.centralheating.co.uk)

### 3.2 Compartment Ventilation

The boilers are very high efficiency appliances.

As a consequence the heat loss from the appliance casing during operation is very low.

Compartment ventilation is not required as the products are only certified, and can only be fitted with a concentric flue system.

### 3.3 Serial number

The serial number is located on a plate behind the front flap. The plate is in a plastic fish plate. You can also display the serial number in the display.

### 3.4 Information on the identification plate

The identification plate is mounted on the underside of the product in the factory.

The identification plate keeps record of the country in which the product is to be installed.

| Information on the identification plate | Meaning  |
|---|--|
|   | Barcode with serial number   |
| Serial number                           | For quality control purposes; 3rd and 4th digits = year of production<br>For quality control purposes; 5th and 6th digits = week of production<br>For identification purposes; 7th to 16th digits = product article number<br>For quality control purposes; 17th to 20th digits = place of manufacture |
| ecoTEC plus                             | Product designation  |
| 3P, G31 – 3.7 kPa (37 mbar)             | Factory setting for type of gas and gas connection pressure  |
| Cat.                                    | Gas-fired boiler category  |
| Condensing technology                   | Efficiency class of the boiler in accordance with EC Directive 92/42/EEC   |
| Type: Xx3(x)                            | Permissible flue gas connections   |
| PMS                                     | Maximum water pressure in heating mode   |
| PMW                                     | Maximum water pressure in hot water handling mode  |
| V/Hz                                    | Electrical connection  |
| W                                       | Max. electrical power consumption  |
| IP                                      | Level of protection  |
|   | Heating mode   |
| P <sub>n</sub>                          | Nominal heat output range in heating mode  |
| P <sub>nc</sub>                         | Nominal heat output range in heating mode (condensing technology)  |
| P                                       | Nominal heat output range in hot water handling mode   |
| Q <sub>n</sub>                          | Nominal heating load range in heating mode   |
| Q <sub>nw</sub>                         | Nominal heating load range in hot water handling mode  |
| T <sub>max.</sub>                       | Max. flow temperature  |
| NO <sub>x</sub>                         | NO <sub>x</sub> class for the product  |

| Information on the identification plate   | Meaning                |
|---|------------------------|
| Code (DSN)  | Specific product code  |
|  | Read the instructions. |
| GC no.  | Gas council number     |

### 3.5 CE label



The CE label shows that the products comply with the basic requirements of the applicable directives as stated on the identification plate.

The declaration of conformity can be viewed at the manufacturer's site.

### 3.6 Functional elements

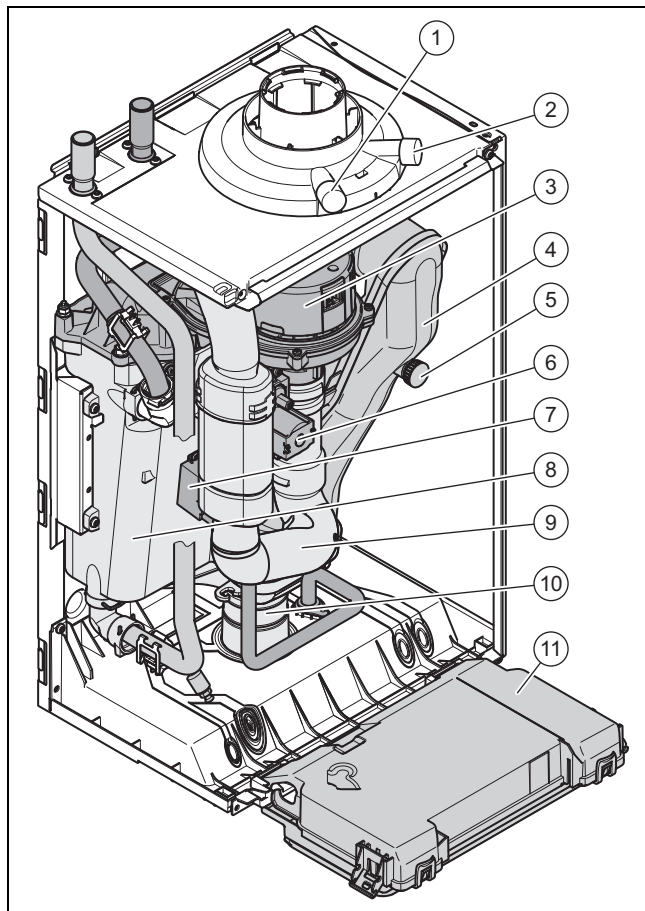

- |   |   |    |  |
|---|---|----|--|
| 1 | Supply air test point (for the upper air/flue connection)   | 5  | Flue gas analysis point (for the rear air/flue connection) |
| 2 | Flue gas analysis point (for the upper air/flue connection) | 6  | Gas valve assembly   |
| 3 | Fan/gas-air mixture   | 7  | Ignition transformer                                       |
| 4 | Flue pipe   | 8  | Heat exchanger   |
|   |   | 9  | Air intake pipe  |
|   |   | 10 | Condensate trap  |
|   |   | 11 | Electronics box  |

## 4 Set-up

### 4.1 Transporting the unit

**Important:** With regard to the regulations of 1992 concerning the manual handling of loads, the unit exceeds the weight that can be lifted by a single person.

#### 4.1.1 General

- ▶ Hold the load as close as possible to your body. Avoid rotational movements. Instead, reposition your feet.
- ▶ If the unit is being lifted by two persons, ensure your movements are coordinated during lifting.
- ▶ Avoid bending your upper body – do not lean forwards or to the side.
- ▶ Wear suitable non-slip protective gloves in order to protect your hands against sharp edges. Ensure that you are carrying the load securely.
- ▶ If required, get somebody to assist you in this.

#### 4.1.2 Unloading the box from the delivery van

- ▶ It is recommended that two people lift the unit together.
- ▶ Lift the box using the straps provided.
- ▶ Use safe lifting techniques – keep your back straight and bend your legs at the knee.
- ▶ Hold the load as close as possible to your body.
- ▶ If the unit is being lifted by two persons, ensure your movements are coordinated during lifting.
- ▶ If required, get somebody to assist you in this.

### 4.2 Unpacking the product

1. Remove the product from its box.
2. Remove the protective film from all of the product's components.

### 4.3 Checking the scope of delivery

- ▶ Check that the scope of delivery is complete and intact.

#### 4.3.1 Scope of delivery

| Number | Description            |
|--------|------------------------|
| 1      | Heat generator         |
| 1      | Hanging bracket        |
| 1      | Flue gas adaptor       |
| 1      | Gas isolator cock      |
| 1      | Gas pipe               |
| 1      | Condensate drain hose  |
| 1      | Installation template  |
| 1      | Enclosed documentation |

## 4 Set-up

### 4.4 Dimensions

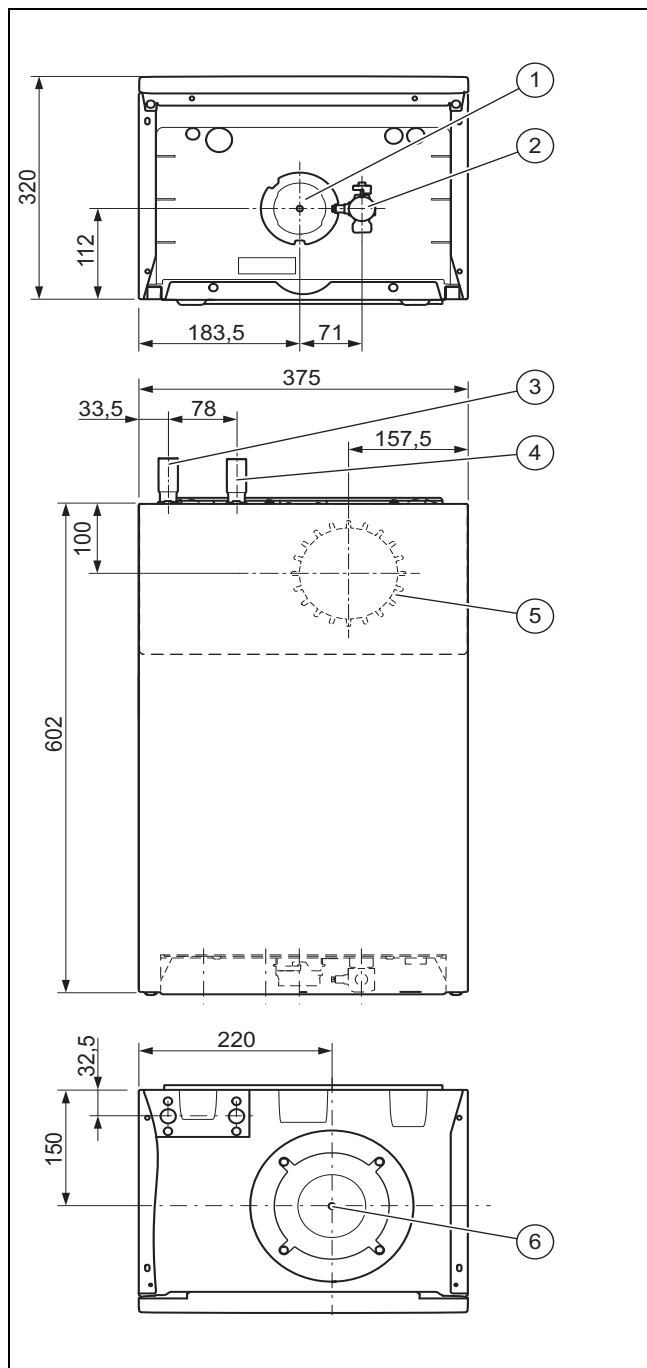

- |   |                      |   |   |
|---|----------------------|---|---|
| 1 | Condensate discharge | 4 | Heating flow                                |
| 2 | Gas connection       | 5 | Connection on the back of the air/flue pipe |
| 3 | Heating return       | 6 | Connection on the top of the air/flue pipe  |

### 4.5 Minimum clearances

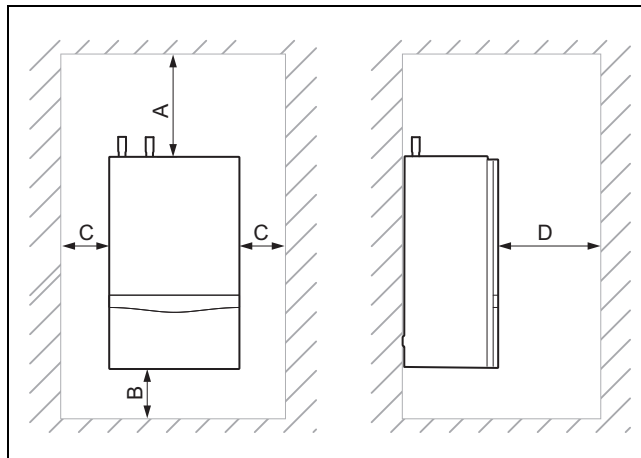

|   | Minimum clearance  |
|---|--|
| A | 150 mm (top air/flue connection)<br>75 mm (rear air/flue connection) * |
| B | 150 mm   |
| C | 5 mm<br>(70 mm if the side sections ought to be removed)               |
| D | 600 mm   |

\* Dimension A can be reduced to 20 mm if there is a removable surface above the product.

### 4.6 Clearance from combustible components

It is not necessary to maintain a clearance between the product and components made of combustible materials that goes beyond the minimum clearances (→ Page 8).

### 4.7 Using the mounting template

- Use the mounting template to ascertain the locations at which you need to drill holes.

### 4.8 Wall-mounting the product



#### Note

If you are using the rear air/flue connection, install the air/flue pipe before you wall-mount the product.

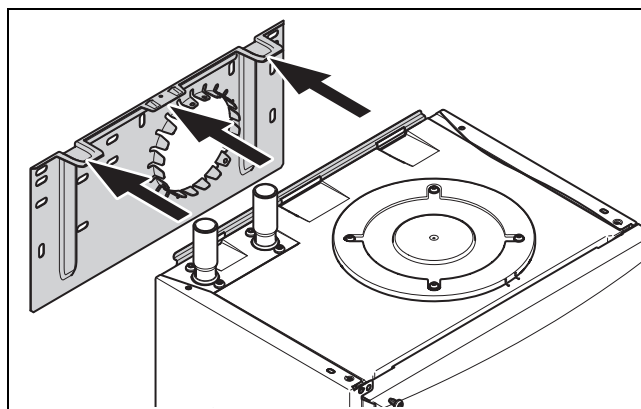

1. Only use fixing material that is permitted for the wall.
2. Check the load-bearing capacity of the wall.
3. Note the total weight of the product.



4. Only use fixing material that is permitted for the wall.
5. If required, ensure that mounting apparatus on-site has sufficient load-bearing capacity.
6. Wall-mount the product as described.

#### 4.9 Removing/installing the front casing

##### 4.9.1 Removing the front casing

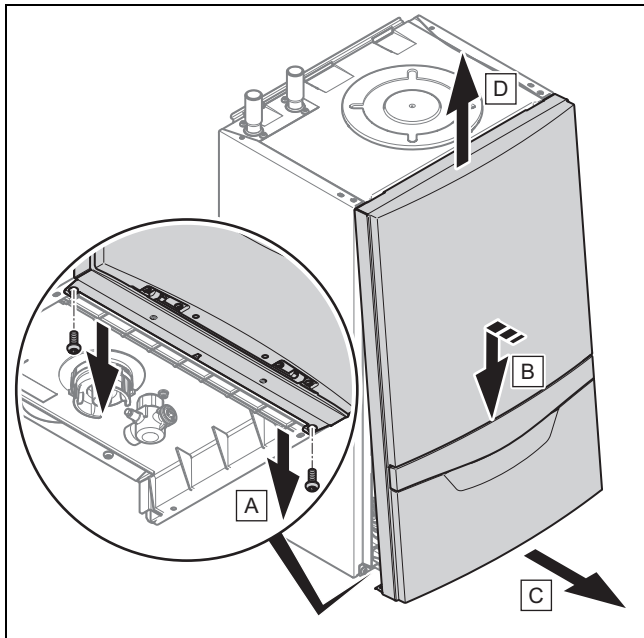

1. Undo the two screws .
2. Gently press the front casing backwards in the centre and pull it downwards on the lower edge so that the retaining clip is released.
3. Pull the front casing forwards at the bottom edge.
4. Lift the front casing upwards from the retainers.

##### 4.9.2 Installing the front casing

- ▶ Refit the components in the reverse order.

#### 4.10 Removing/installing the side section

##### 4.10.1 Removing the side section



**Caution.**  
**Risk of material damage caused by mechanical deformation.**

Removing **both** side sections may cause mechanical distortion in the product, which may cause damage to the piping, for example, and potentially result in leaks.

- ▶ Always remove **only one** side section – never both side sections at the same time.



**Note**  
If there is sufficient lateral clearance (at least 70 mm), you can remove the side section to facilitate maintenance or repair work.

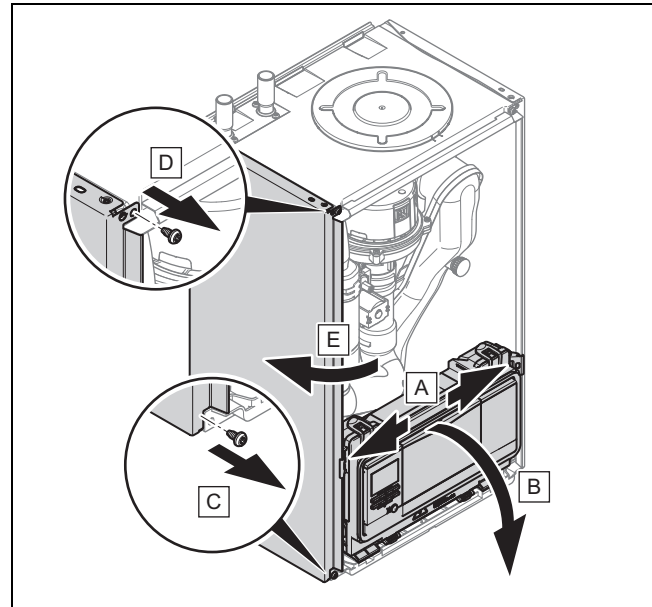

1. Tilt the electronics box forward.
2. Hold on to the side section so that it cannot fall, and unscrew both screws, one from the top and one from the bottom.
3. Tilt the side section to the outside and take it out towards the top.

##### 4.10.2 Installing the side section

- ▶ Refit the components in the reverse order.

## 5 Installation

### 5.1 Preparing for installation



**Danger!**  
**Risk of scalding and/or damage due to incorrect installation leading to escaping water.**

Mechanical stresses in the connection pipes may lead to leaks.

- ▶ Install the connection pipes such that they are free from mechanical stress.



**Caution.**  
**Risk of material damage caused by corrosion**

Due to non-diffusion-tight plastic pipes in the heating installation, air gets into the heating water. Air in the heating water causes corrosion in the heat generator circuit and in the product.

- ▶ If you use non-diffusion-tight plastic pipes in the heating installation, ensure that no air gets into the heat generator circuit.

## 5 Installation



**Caution.**  
**Risk of material damage caused by residues in the pipelines.**

Welding remnants, sealing residues, dirt or other residues in the pipelines may damage the product.

- ▶ Flush the heating installation thoroughly before installing the product.



**Caution.**  
**Risk of material damage due to heat transfer during soldering.**

- ▶ Only solder connectors if the connectors are not yet screwed to the service valves.



**Caution.**  
**Risk of material damage caused by changes to the pipes that have already been connected.**

- ▶ Only bend connection pipes if they have not yet been connected to the product.



**Caution.**  
**Risk of damage caused by incorrect gas installation.**

Excess test pressure or operating pressure may cause damage to the gas valve.

- ▶ Check the leak-tightness of the gas valve using a maximum pressure of 11 kPa (110 mbar).

- ▶ Make sure that the existing gas meter is capable of passing the rate of gas supply required.
- ▶ Install the following components:
  - Drain cocks at the lowest points in the heating installation (→ current version of "BS 2879")
  - A heating pump in the heating flow
  - A bypass that is at least 1.5 m away from the product
  - A stop cock in the gas pipe
  - Where applicable, a flow regulator valve to adjust the flow rate

### Pressure loss from the product

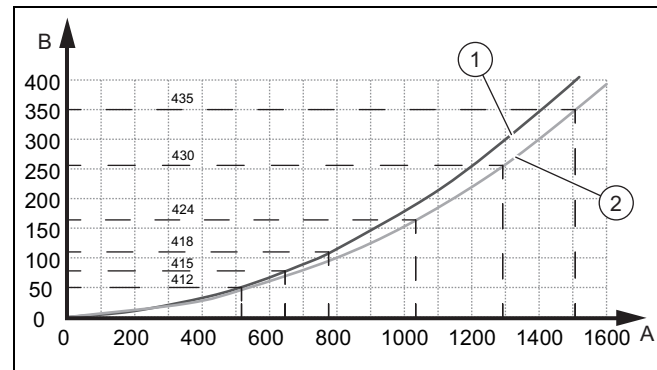

|   |                      |   |                         |
|---|----------------------|---|-------------------------|
| A | Flow rate [l/h]      | 1 | Pressure loss 412 - 418 |
| B | Pressure loss [mbar] | 2 | Pressure loss 424 - 435 |

The flow rate must not fall below the value in the diagram.

- ▶ Check that the volumetric capacity of the expansion vessel is sufficient for the system volume.

### 5.2 Installing the heating pump

- ▶ Only use pumps that have an in-rush current  $\leq 10/15$  A.
- ▶ When designing/selecting the pump, note the pressure loss of the product.
- ▶ Install the pump in the heating flow.
- ▶ Install the pump upstream and downstream of the pump isolation valves.
- ▶ Set the pump so that the temperature difference between the flow and return is no more than 20 °C when the maximum flow temperature is set.
  - The flow rate specified in the technical data is reached.

## 5.3 Heating water supply in the open heating system

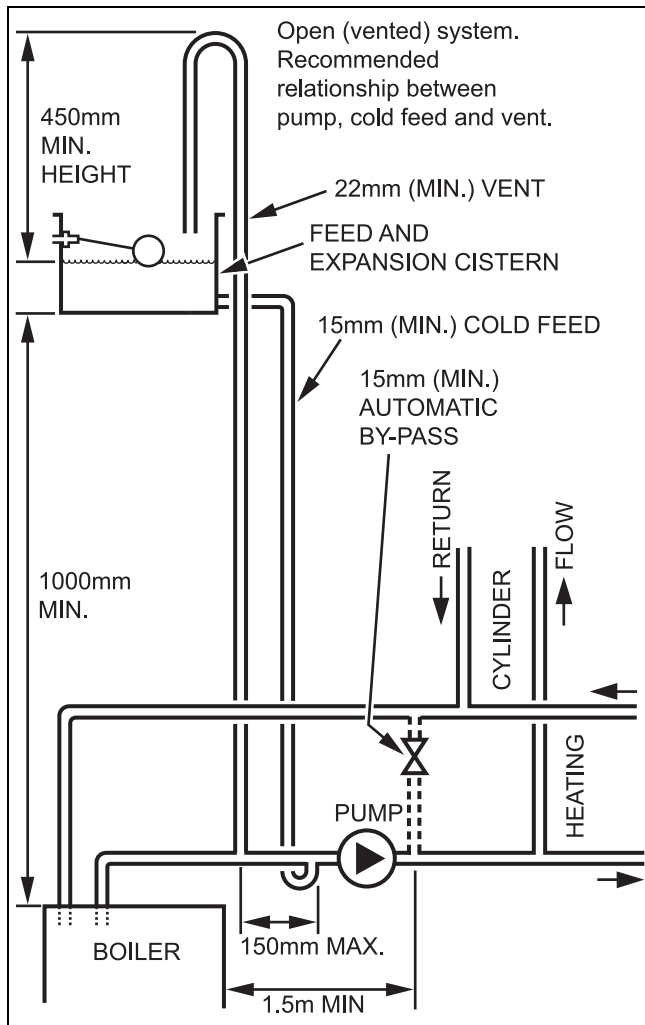

- ▶ Connect the product to a supply/expansion tank as shown in the figure.
  - The tank must not be more than 27 m (90 ft) above the product.
  - The open vent pipe must be installed with an upward gradient and must not be blocked.
  - Supply line diameter:  $\geq 15$  mm
  - The relative positions of the pump, supply and open vent pipe must be as shown in the figure.

**Conditions:** Combined supply and open vent pipe

- ▶ Install the line in accordance with "BS 5449".
  - Diameter:  $\geq 22$  mm

## 5.4 Purging the liquid gas tank

If the liquid gas tank is not purged properly, this may result in ignition problems.

- ▶ Ensure that the liquid gas tank has been purged properly before installing the product.
- ▶ If required, contact the filler or the liquid gas supplier.

## 5.5 Using the correct gas type

Using the incorrect gas type may cause fault shutdowns in the product. Ignition and combustion noise may occur in the product.

- ▶ Only use the gas type listed on the data plate.

## 5.6 Connecting the heating flow and heating return

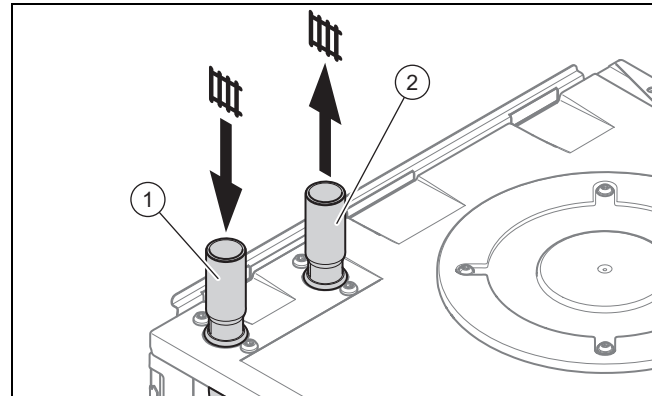

- 1 Heating return connection
  - 2 Heating flow connection
1. Establish the heating connections in accordance with the applicable standards.
  2. Check whether the connections (→ Page 19) are leak-tight.

## 5.7 Gas connection

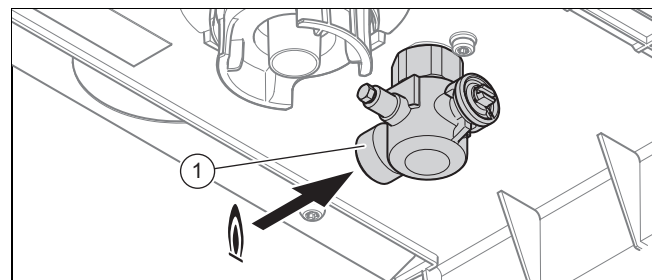

1. Establish the gas connection (1) in accordance with the applicable standards.
2. Purge the gas line before start-up.
3. Check the entire gas line properly for leak-tightness.

## 5 Installation

### 5.8 Connecting the condensate discharge pipe

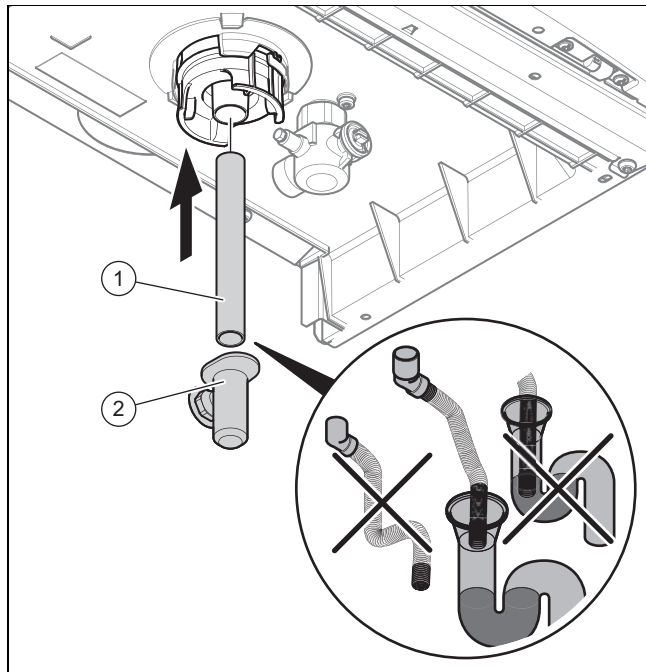

- ▶ Follow the instructions listed here and observe the legal and local regulations on condensate discharge.
- ▶ Use PVC or any other material that is suitable for draining the non-neutralised condensate.
- ▶ If you cannot guarantee that the materials from which the drain pipework is made are suitable, install a system for neutralising the condensate.
- ▶ Ensure that the connection between the condensate discharge pipe and the drain hose is not air-tight.



#### Note

The condensate drain pipework must have a continuous fall (45 mm per metre) and should whenever possible terminate at a suitable drain point within the heated envelope of the building that will remain frost free under long periods of low external temperatures.

- ▶ During installation remove all burrs from inside of cut pipe work and avoid excessive adhesive which may trap small pockets of water close to the pipe wall which can freeze and build into a larger ice plug.
- ▶ For any installation the condensate must be free flowing and not be possible for air back-pressure to prevent water flow.
- ▶ As with other pipe work insulate the condensate discharge pipe to minimise any risk of freezing and beware when crossing cavities that the fall is maintained and the pipe sleeved.

You can find further information in specification "BS 6798" for installing and maintaining gas-fired boilers with a nominal heat input below 70 kW.

### 5.8.1 Condensate drainage systems

#### 5.8.1.1 Internal soil and vent pipe

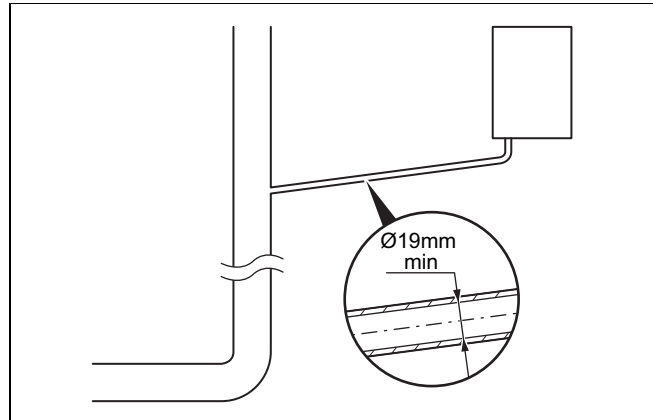

#### 5.8.1.2 External soil and vent pipe

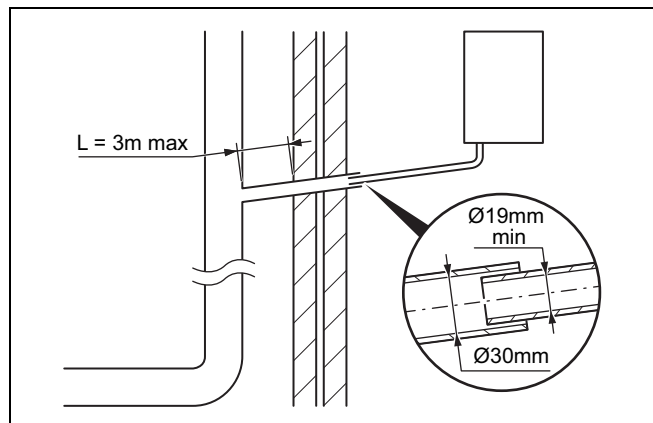

#### 5.8.1.3 External termination into a gully or hopper

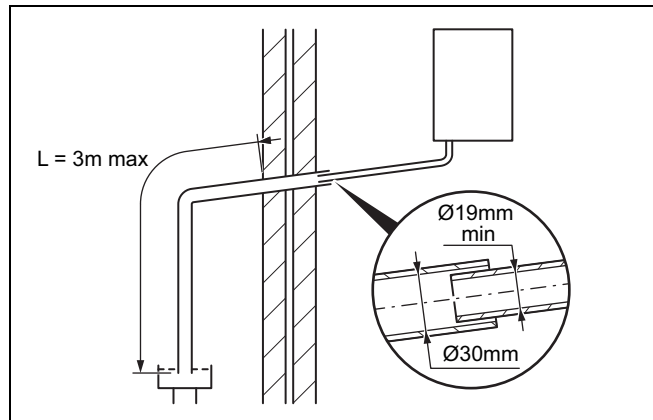

5.8.1.4 Internal termination into combined sink waste

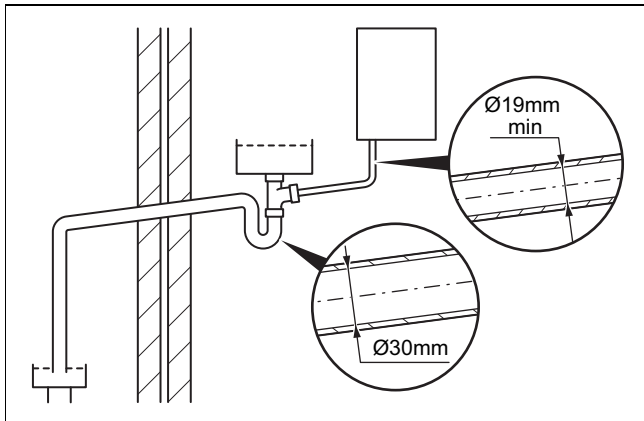

5.8.1.7 External termination into rain water down pipe

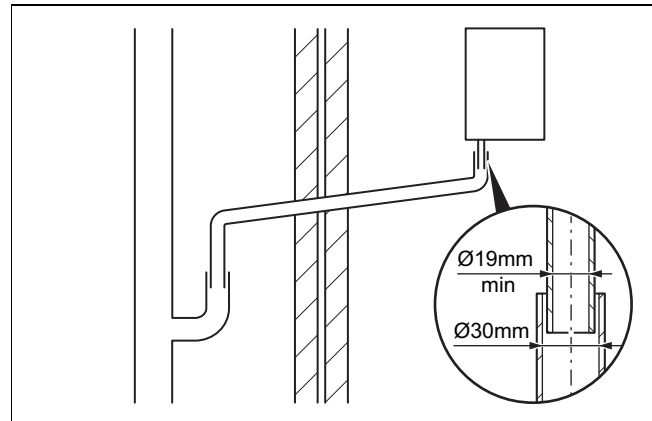

5.8.1.5 Internal termination downstream of sink waste

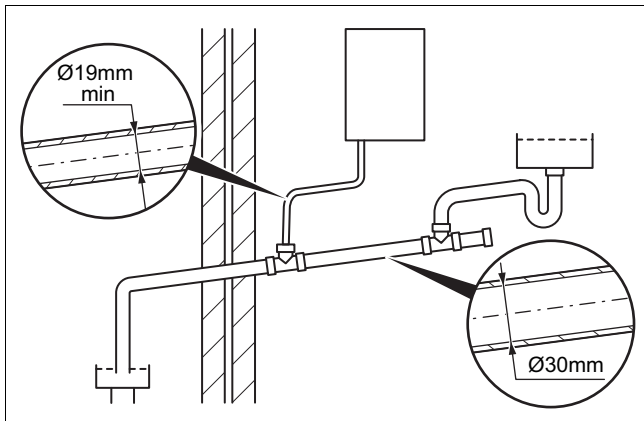

5.9 Electrical installation



**Danger!**  
**Risk of death from electric shock!**

Continuous voltage is present at power supply terminals L and N even when the unit is switched off using the standby button.

- ▶ Switch off the power supply.
- ▶ Secure the power supply against being switched on again.

Only qualified electricians may carry out the electrical installation.

5.8.1.6 External termination into soakaway

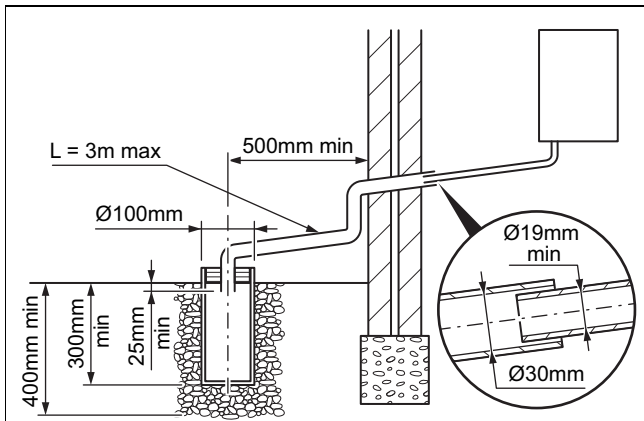

5.9.1 Opening the electronics box

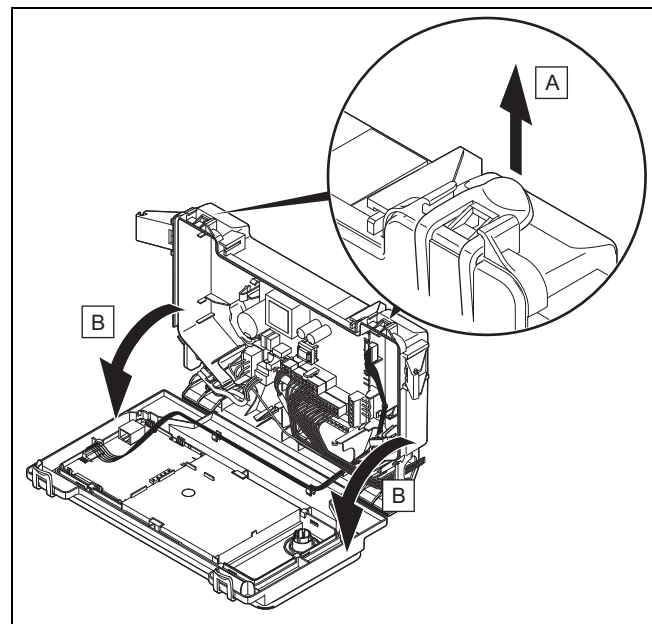

- ▶ Follow the instructions in the specified sequence.

## 5 Installation

### 5.9.2 Cable route

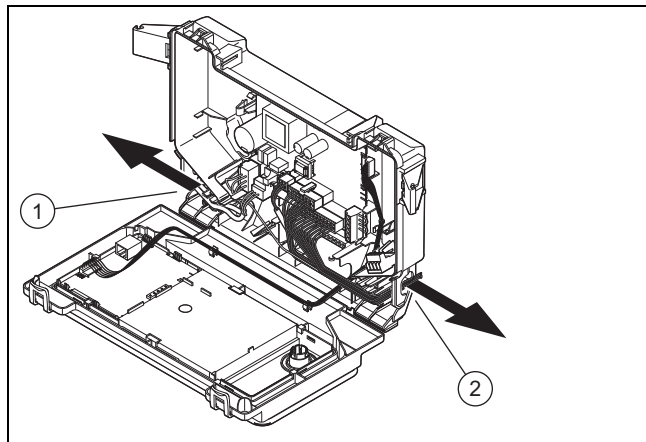

- 1 230-V cable route      2 24-V cable or eBUS cable route

### 5.9.3 Carrying out the wiring

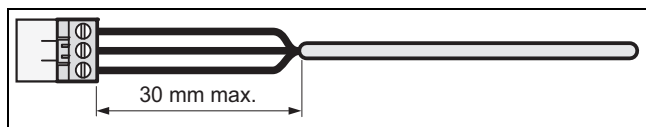

1. Shorten the connection cables to the appropriate lengths to prevent them from causing damage inside the electronics box.
2. Screw the plug to the connection cable.
3. Plug the plug into the slot provided on the PCB.

### 5.9.4 Establishing the power supply

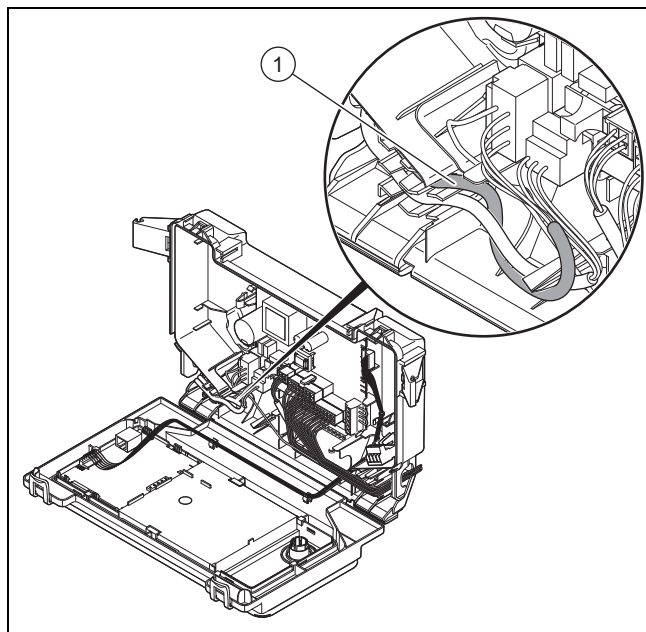

1. Observe all valid regulations.
2. Ensure that the rated mains voltage is 230 V.
3. Set up a fixed connection and install a partition with a contact opening of at least 3 mm (e.g. fuses or power switches).
4. Provide one common electricity supply for the boiler and for the corresponding controller:

- Power supply: Single-phase, 230 V, 50 Hz
- Fuse protection:  $\leq 3$  A

5. Open the electronics box. (→ Page 13)
6. Observe the routing of the power supply cable (1) in the electronics box in order to guarantee that there is no strain.

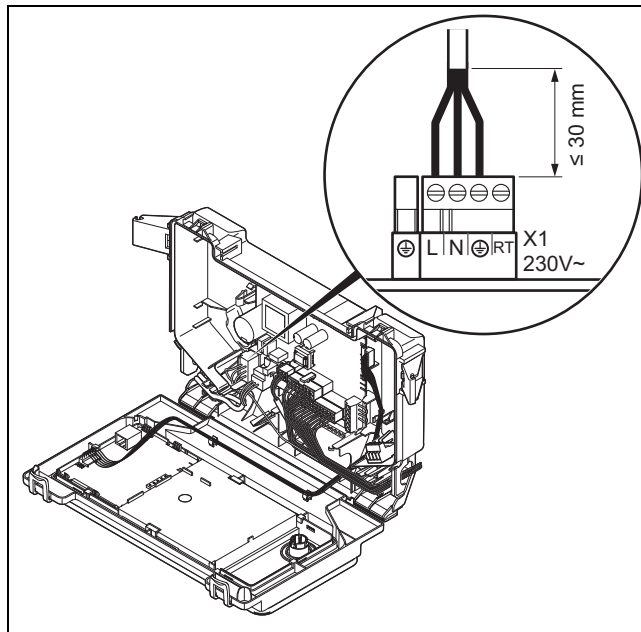

7. Carry out the wiring. (→ Page 14)
8. Close the electronics box.
9. Make sure that access to the mains connection is always available and is not covered or blocked.

### 5.9.5 Connecting controls to the electronics

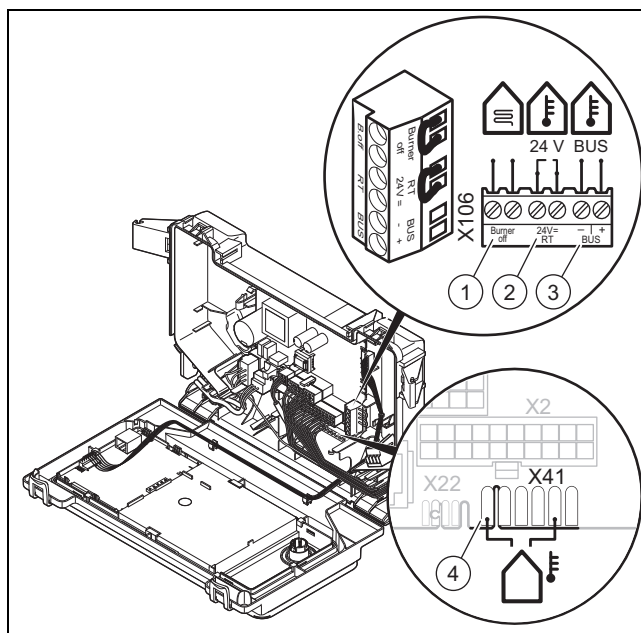

- |  |                                       |
|--|---------------------------------------|
| 1 Safety thermostat for underfloor heating | 3 eBUS control or radio receiver unit |
| 2 24 V control                             | 4 Outdoor temperature sensor, wired   |

1. Open the electronics box. (→ Page 13)
2. Carry out the wiring. (→ Page 14)
3. Connect the individual components depending on the installation type.

**Conditions:** If installing a multi-circuit controller.

- ▶ Change the pump's operating mode **d.18** from Eco (intermittently operating pump) to Comfort (continuously operating pump).

**Conditions:** When connecting a control (230 V).

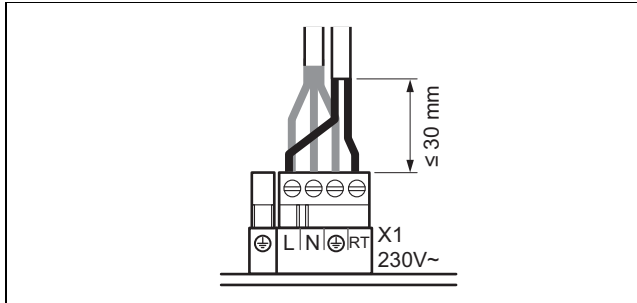

- ▶ Connect the control to the main plug.
- ▶ Remove the bridge from the plug **24V=RT**.

**Conditions:** 230 V 3-wire connection

- ▶ Connect the boiler only using the set with article number 0020244337 (Installation Kit, 3-wire, Vaillant).
    - When connecting, observe the instructions for the set.
  - ▶ Connect the control to the main plug X1.
    - Terminal assignment: L – Phase, N – neutral conductor, ⊕ – earth
  - ▶ Draw the end user's attention to the fact that the following features are present with this installation type.
    - ◁ The frost protection function is deactivated. If the product is installed in a room where there is a risk of frost and it has not been protected by a room thermostat, install an additional frost protection thermostat.
    - ◁ The pump programmes are not active.
    - ◁ If the product is switched off, the display is switched off.
    - ◁ Each time the unit is started, the fan runs for 20 seconds.
    - ◁ Residual heat in the heating return may result in the product blocking the burner for 10 minutes.
4. Close the electronics box.

## 6 Operation



### 6.1 Operating concept

The operating concept and the read-off and setting facilities of the operator level are described in the operating instructions.

An overview of the reading and setting options for the installer level is included in the table in the appendix.

Installer level – Overview (→ Page 27)

### 6.2 Calling up the installer level

1. Only call up the installer level if you are a competent person.
2. Navigate to **Menu** → **Installer level** and confirm by pressing .
3. Set the value **17** (code) and confirm by pressing .

### 6.3 Live Monitor (status codes)

**Menu** → **Live Monitor**

Status codes in the display provide information on the product's current operating status.

Status codes – Overview (→ Page 32)

## 7 Start-up

### 7.1 Carrying out the initial start-up

Initial start-up must be carried out by a customer service technician or an authorised competent person using the first-commissioning-checklist. The first-commissioning-checklist in the appendix (→ Page 38) of the installation instructions must be filled out and stored carefully along with the unit's documentation.

- ▶ Carry out the initial start-up using the first-commissioning-checklist in the appendix.
- ▶ Fill out and sign the first-commissioning-checklist.

### 7.2 Running the installation assistants

The installation assistant is displayed whenever the product is switched on until it has been successfully completed. It provides direct access to the most important check programmes and configuration settings for starting up the product.

To recheck and reset the most important system parameters, call up the **Appliance config.**

**Menu** → **Installer level** → **Appliance config.**

The settings options for more complex systems can be found in the **Diagnostics menu**.

**Menu** → **Installer level** → **Diagnostics menu**

- ▶ Press  to confirm installation assistant start-up.
  - ◁ All heating and hot water requests are blocked whilst the installation assistant is active.



#### Note

If you do not confirm the launch of the installation assistant within 10 seconds of switching the system on, the basic display reappears.







- ▶ To access the next point, confirm by pressing  in each case.

#### 7.2.1 Language

- ▶ Set the required language.
- ▶ To confirm the set language and to avoid unintentionally changing it, press  twice to confirm this.

## 7 Start-up



If you have unintentionally set a language that you do not understand, proceed as follows to change it:

- ▶ Press and hold  and  at the same time.
- ▶ Also briefly press .
- ▶ Press and hold  and  until the display shows the language setting option.
- ▶ Select the required language.
- ▶ Press  twice to confirm this change.



### 7.2.2 Filling mode

Filling mode (check programme **P.06**) is activated automatically in the installation assistant for as long as the filling mode appears on the display.

### 7.2.3 Purging

1. Unlike in the **Check programs** menu, to purge the system, start check programme **P.00** by pressing  or .
2. If you need to change the circuit that is to be purged, press .

### 7.2.4 Target flow temperature, hot water temperature

1. To set the target flow temperature and hot water temperature, use  and .
2. Press  to confirm this setting.

**Conditions:** Water hardness: > 3.57 mol/m<sup>3</sup>, Product with connected cylinder



#### **Danger!** **Risk of death from legionella.**

Legionella multiply at temperatures below 60 °C.

- ▶ Ensure that the end user is familiar with all of the Anti-legionella measures in order to comply with the applicable regulations regarding legionella prevention.

- ▶ Set the hot water temperature.
  - Water temperature: ≤ 50 °C

### 7.2.5 Heating partial load

The heating partial load of the product is set to **Auto** at the factory. The product independently determines the optimum heating output depending on the current heat demand of the system. You can retroactively change the setting in the **Diagnostics menu** under **D.000**.

### 7.2.6 Auxiliary relay and multi-functional module

1. If you have connected additional components to the product, assign these components to the individual relays.
2. In each case, confirm by pressing .



#### **Note**

This setting can be retroactively changed in the **Diagnostics menu** using **D.026**, **D.027** and **D.028**.

### 7.2.7 Contact data

- ▶ If required, store your telephone number in the **Appliance config.** (max. 16 digits/no blank spaces). The operator can view the telephone number.

### 7.2.8 Ending the installation assistant

- ▶ Once you have run through the installation assistant successfully, confirm by pressing .
- ◀ The installation assistant will close and will not launch again when the product is next switched on.

## 7.3 Restarting the installation assistants

**Menu** → **Installer level** → **Start inst. assistant**

You can restart the installation assistant at any time by calling it up in the menu.

## 7.4 Test programmes

**Menu** → **Installer level** → **Test programs**

As well as the installation assistants, you can also call up the following test programmes for start-up, service and troubleshooting.

- **Check programs**
- **Function menu**
- **Electronics self-test**

## 7.5 Checking the factory setting

The product's combustion has been factory tested and is preset for operation with the gas group indicated on the identification plate.

- ▶ Check the information about the type of gas indicated on the identification plate and compare this with the type of gas available at the installation location.

**Conditions:** The product design is **not compatible** with the local gas group

- ▶ Do not start up the product.

**Conditions:** The product design is **compatible** with the local gas group

- ▶ Proceed as described below.

## 7.6 Checking and treating the heating water/filling and supplementary water



#### **Caution.**

#### **Risk of material damage due to poor-quality heating water**

- ▶ Ensure that the heating water is of sufficient quality.

- ▶ Before filling or topping up the installation, check the quality of the heating water.

#### **Checking the quality of the heating water**

- ▶ Remove a little water from the heating circuit.
- ▶ Check the appearance of the heating water.
- ▶ If you ascertain that it contains sedimentary materials, you must desludge the installation.



- ▶ Use a magnetic rod to check whether it contains magnetite (iron oxide).
- ▶ If you ascertain that it contains magnetite, clean the installation and apply suitable corrosion-protection measures, or fit a magnetic filter.
- ▶ Check the pH value of the removed water at 25 °C.
- ▶ If the value is below 6.5 or above 8.5, clean the system and treat the heating water.
- ▶ Ensure that oxygen cannot get into the heating water.

**Checking the filling and supplementary water**

- ▶ Before filling the installation, measure the hardness of the filling and supplementary water.

**Treating the filling and supplementary water**

- ▶ Observe all applicable national regulations and technical standards when treating the filling and supplementary water.

Provided the national regulations and technical standards do not stipulate more stringent requirements, the following applies:

You must treat the heating water in the following cases:

- If the entire filling and supplementary water quantity during the operating life of the system exceeds three times the nominal volume of the heating installation, or
- If the guideline values listed in the following table are not met, or
- if the pH value of the heating water is less than 6.5 or more than 8.5.

| Total heating output | Water hardness at specific system volume <sup>1)</sup> |                    |                        |                    |                       |                    |
|----------------------|--|--------------------|------------------------|--------------------|-----------------------|--------------------|
|                      | ≤ 20 l/kW  |                    | > 20 l/kW<br>≤ 50 l/kW |                    | > 50 l/kW             |                    |
| kW                   | ppm CaCO <sub>3</sub>                                  | mol/m <sup>3</sup> | ppm CaCO <sub>3</sub>  | mol/m <sup>3</sup> | ppm CaCO <sub>3</sub> | mol/m <sup>3</sup> |
| < 50                 | < 300  | < 3                | 200                    | 2                  | 2                     | 0.02               |
| > 50<br>to ≤ 200     | 200  | 2                  | 150                    | 1.5                | 2                     | 0.02               |
| > 200<br>to ≤ 600    | 150  | 1.5                | 2                      | 0.02               | 2                     | 0.02               |
| > 600                | 2  | 0.02               | 2                      | 0.02               | 2                     | 0.02               |

1) Nominal capacity in litres/heating output; in the case of multi-boiler systems, the smallest single heating output is to be used.



**Caution.**  
**The use of unsuitable heating water may cause aluminium corrosion and a resulting lack of leak-tightness.**

In contrast to steel, grey cast iron or copper, for example, aluminium reacts with alkaline heating water (pH value > 8.5) to produce substantial corrosion.

- ▶ When using aluminium, make sure that the pH value of the heating water is between 6.5 and a maximum of 8.5.



**Caution.**  
**Risk of material damage if the heating water is treated with unsuitable additives.**

Unsuitable additives may cause changes in the components, noises in heating mode and possibly subsequent damage.

- ▶ Do not use any unsuitable frost and corrosion protection agents, biocides or sealants.

No incompatibility with our products has been detected to date with proper use of the following additives.

- ▶ When using additives, follow the manufacturer's instructions without exception.

We accept no liability for the compatibility of any additive or its effectiveness in the rest of the heating system.

**Additives for cleaning measures (subsequent flushing required)**

- Adey MC3+
- Adey MC5
- Fernox F3
- Sentinel X 300
- Sentinel X 400

**Additives intended to remain permanently in the installation**

- Adey MC1+
- Fernox F1
- Fernox F2
- Sentinel X 100
- Sentinel X 200

**Additives for frost protection intended to remain permanently in the installation**

- Adey MC ZERO
- Fernox Antifreeze Alphi 11
- Sentinel X 500
- ▶ If you have used the above-mentioned additives, inform the end user about the measures that are required.
- ▶ Inform the end user about the measures required for frost protection.

## 7 Start-up

### 7.7 Filling the condensate trap

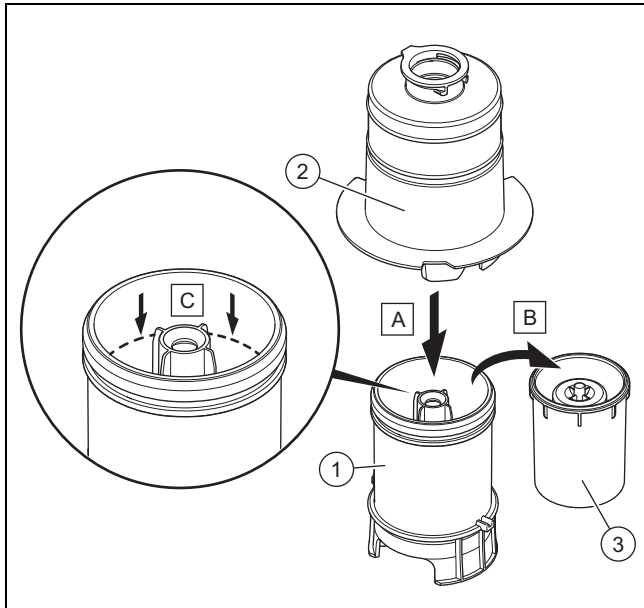

1. Unclip the lower section of the condensate trap (1) from the upper section of the condensate trap (2).
2. Remove the float (3).
3. Fill the lower section of the condensate trap with water up to 10 mm below the upper edge of the condensate discharge pipe.
4. Re-insert the float (3).



#### Note

Check whether the float is present in the condensate trap.

5. Clip the lower section of the condensate trap (1) into the upper section of the condensate trap (2).

### 7.8 Switching on the product

- ▶ Switch on the product via the main switch installed on-site.

### 7.9 Filling the heating installation

1. Flush the heating installation through.
2. Fill the heating installation with the maximum possible volume flow.

### 7.10 Checking the gas flow rate

The gas flow rate has been set during production and does not require adjustment. With the front casing fitted check the gas flow rate of the boiler as follows:

- ▶ Start up the product with the check programme **P.01**.
- ▶ In addition, ensure that maximum heat can be dissipated into the heating system by turning up the room thermostat.
- ▶ Wait at least 5 minutes until the boiler has reached its operating temperature.
- ▶ Ensure that all other gas appliances in the property are turned off.
- ▶ Measure the gas flow rate at the gas meter.
- ▶ Compare the measured values with the corresponding values in the table.

| Q <sub>nw</sub> from the data plate | P gas in kg/h |      |      |
|-------------------------------------|---------------|------|------|
|                                     | Nom.          | +5%  | -10% |
| 24.7                                | 1.92          | 2.02 | 1.73 |
| 25.7                                | 2.00          | 2.10 | 1.80 |
| 30.6                                | 2.38          | 2.50 | 2.14 |

**Conditions:** Gas flow rate not in the permissible range

- ▶ Check all of the piping and ensure that the gas flow rates are correct.
- ▶ Only put the product into operation once the gas flow rates have been corrected.

**Conditions:** Gas flow rate in the permissible range

- ▶ End the check programme **P.01**.
- ▶ Allow the boiler to cool down by allowing pump overrun to operate for a minimum of 2 minutes.
- ▶ Record the boiler maximum gas flow rate onto the Benchmark gas boiler commissioning checklist.

### 7.11 Checking and adjusting the gas settings

Only a qualified competent person is authorised to implement the settings on the gas valve assembly.

Each destroyed tamper-proof seal must be replaced.

The CO<sub>2</sub> adjusting screw must be sealed.

Never modify the factory setting of the gas pressure regulator of the gas valve assembly.

#### 7.11.1 Checking the gas connection pressure (gas flow pressure)

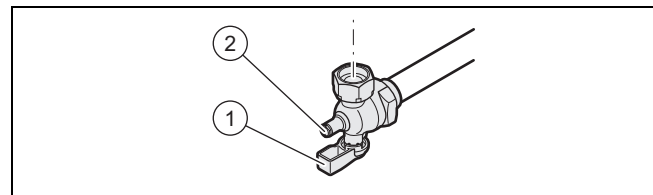

1. Ensure that the gas inlet working pressure can be obtained with all other gas appliances in the property working.
2. Close the gas stopcock (1).
3. Undo the sealing screw on the test nipple (2).
4. Connect a manometer to the test nipple (2).
5. Open the gas stopcock (1).
6. Start up the product with check programme **P.01** (system with eBUS control) or **P.03** (installation without eBUS control).
7. In addition, ensure that maximum heat can be dissipated into the heating system by turning up the room thermostat.
8. With the boiler operating at full load check that the gas inlet working pressure at the reference test point (2) complies with the requirements.

#### Permissible connection pressure

| Great Britain | Liquid gas | G31 | 2.5<br>... 3.7 kPa<br>(25.0<br>... 37.0 mbar) |
|---------------|------------|-----|---|
|               |            |     |   |

- Should the pressure recorded at the reference test point in the boiler be lower than indicated check if there is any blockage in the pipework or if the pipework is undersized.

**Conditions:** Gas flow pressure **not** in the permissible range



**Caution.**

**Risk of material damage and operating faults caused by incorrect gas connection pressure.**

If the gas connection pressure lies outside the permissible range, this can cause operating faults in and damage to the product.

- ▶ Do not make any adjustments to the product.
- ▶ Do not start up the product.

- ▶ If you cannot correct the failure, notify the gas supply company and proceed as follows:
- ▶ End check programme P.01.
- ▶ Allow the boiler to cool down by allowing pump overrun to operate for a minimum of two minutes.
- ▶ Close the gas stopcock.
- ▶ Remove the pressure gauge and retighten the sealing screw (2) for the measuring nipple.
- ▶ Open the gas stopcock (1).
- ▶ Check the test nipple for gas tightness.
- ▶ Close the gas stopcock (1).
- ▶ Install the front casing. (→ Page 9)
- ▶ Disconnect the product from the electrical installation.
- ▶ You must not start up the boiler.

**Conditions:** Gas flow pressure **in** the permissible range

- ▶ End the check programme **P.01**.
- ▶ Allow the boiler to cool down allowing pump overrun to operate for a minimum of two minutes.
- ▶ Close the gas stopcock (1).
- ▶ Remove the pressure gauge and retighten the sealing screw (2) for the measuring nipple.
- ▶ Open the gas stopcock (1).
- ▶ Check the test nipple for gas tightness.
- ▶ Remove the front casing. (→ Page 9)
- ▶ Reset boiler controls for normal operation.
- ▶ Record the appliance gas inlet working pressure (kPa resp. mbar) in the Benchmark gas boiler commissioning checklist.

**7.11.2 Checking the leak-tightness of the flue gas installation and flue gas recirculation**

- Check the flue gas installation is intact in accordance with the latest gas safe technical bulletin and information supplied in the installation instructions.
- For extended flue gas installations check for flue gas recirculation using the air analysis point.
- Use a flue gas analyser.
- If you discover CO or CO<sub>2</sub> in the supply air, search for the leak in the flue gas installation or for signs of flue gas recirculation.
- Eliminate the damage properly.

- Check again whether the supply air contains any CO or CO<sub>2</sub>.
- If you cannot eliminate the damage, do not start up the product.

**7.11.3 Checking the CO<sub>2</sub> content**

- Start up the product with check programme (P.01). Installer level – Overview (→ Page 27)
- Wait until the value that is read is stable.
  - Waiting period for reading a stable value: 5 min

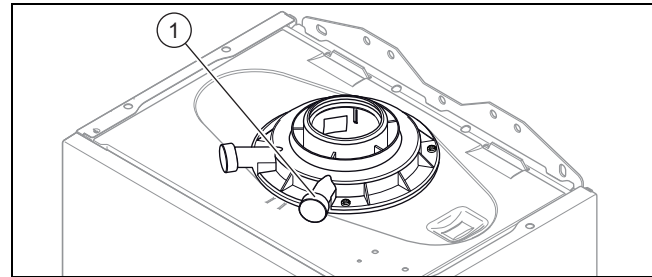

- Unscrew the cover from the flue gas analysis point (1).
- Measure the CO<sub>2</sub> content at the flue gas analysis point (1).
- Compare the measured value with the corresponding value in the table.

**Checking the CO<sub>2</sub> content**

| Great Britain    |                 |
|------------------|-----------------|
| front casing off | front casing on |
| Liquid gas       | Liquid gas      |
| G31              | G31             |
| 10.1 ±1.0 %      | 10.3 ±1.0 %     |

- ◁ The value is OK.
- ▽ The value is not OK; you cannot start up the product.
  - ▶ Inform Customer Service.

**7.12 Checking leak-tightness**

- ▶ Check the gas pipe, the heating circuit and the hot water circuit for leak-tightness.
- ▶ Check that the air/flue pipe has been installed correctly.

**Conditions:** Room-sealed operation

- ▶ Check whether the vacuum chamber has been closed tightly.

**7.13 Checking the heating mode**

- Activate the heating mode on the user interface.
- Turn all thermostatic radiator valves on the radiators until they are fully open.
- Allow the product to operate for at least 15 minutes.
- Purge the heating installation.
- Call up the **Live Monitor**.
  - **Menu** → **Live Monitor**
 Status codes – Overview (→ Page 32)
  - ◁ If the product is working correctly, the display shows **S.04**.

## 8 Adapting the unit to the heating installation

### 8 Adapting the unit to the heating installation

You can reset/change the system parameters using the following menu points:

**Menu → Installer level → Start inst. assistant**

You can restart and run through the installation assistant at any time.

**Menu → Installer level Appliance config.**

You can set/change the most important system parameters in the **Appliance config.** menu point.

**Menu → Installer level Diagnostics menu**

You can set/change additional system parameters in the **Diagnostics menu** point.

You can find an overview of all the system parameters in the "Installer level – Overview" table in the appendix.

Installer level – Overview (→ Page 27)

#### 8.1 Burner anti-cycling time

To prevent frequent switching on and off of the burner and thus prevent energy losses, an electronic restart lockout is activated for a specific period each time the burner is switched off. The burner anti-cycling time is only active for the heating mode. Hot water handling mode during a burner anti-cycling time does not affect the time function element.

##### 8.1.1 Setting the burner anti-cycling time

- ▶ Set the burner anti-cycling time via the diagnostics code. Overview of diagnostics codes (→ Page 29)

| T <sub>Flow</sub> (target) [°C] | Set maximum burner anti-cycling time [min] |     |     |      |      |      |      |
|---------------------------------|--|-----|-----|------|------|------|------|
|                                 | 1  | 5   | 10  | 15   | 20   | 25   | 30   |
| 30                              | 2.0  | 4.0 | 8.5 | 12.5 | 16.5 | 20.5 | 25.0 |
| 35                              | 2.0  | 4.0 | 7.5 | 11.0 | 15.0 | 18.5 | 22.0 |
| 40                              | 2.0  | 3.5 | 6.5 | 10.0 | 13.0 | 16.5 | 19.5 |
| 45                              | 2.0  | 3.0 | 6.0 | 8.5  | 11.5 | 14.0 | 17.0 |
| 50                              | 2.0  | 3.0 | 5.0 | 7.5  | 9.5  | 12.0 | 14.0 |
| 55                              | 2.0  | 2.5 | 4.5 | 6.0  | 8.0  | 10.0 | 11.5 |
| 60                              | 2.0  | 2.0 | 3.5 | 5.0  | 6.0  | 7.5  | 9.0  |
| 65                              | 2.0  | 1.5 | 2.5 | 3.5  | 4.5  | 5.5  | 6.5  |
| 70                              | 2.0  | 1.5 | 2.0 | 2.5  | 2.5  | 3.0  | 3.5  |
| 75                              | 2.0  | 1.0 | 1.0 | 1.0  | 1.0  | 1.0  | 1.0  |

| T <sub>Flow</sub> (target) [°C] | Set maximum burner anti-cycling time [min] |      |      |      |      |      |
|---------------------------------|--|------|------|------|------|------|
|                                 | 35   | 40   | 45   | 50   | 55   | 60   |
| 30                              | 29.0                                       | 33.0 | 37.0 | 41.0 | 45.0 | 49.5 |
| 35                              | 25.5                                       | 29.5 | 33.0 | 36.5 | 40.5 | 44.0 |
| 40                              | 22.5                                       | 26.0 | 29.0 | 32.0 | 35.5 | 38.5 |
| 45                              | 19.5                                       | 22.5 | 25.0 | 27.5 | 30.5 | 33.0 |
| 50                              | 16.5                                       | 18.5 | 21.0 | 23.5 | 25.5 | 28.0 |
| 55                              | 13.5                                       | 15.0 | 17.0 | 19.0 | 20.5 | 22.5 |
| 60                              | 10.5                                       | 11.5 | 13.0 | 14.5 | 15.5 | 17.0 |

| T <sub>Flow</sub> (target) [°C] | Set maximum burner anti-cycling time [min] |     |     |      |      |      |
|---------------------------------|--|-----|-----|------|------|------|
|                                 | 35   | 40  | 45  | 50   | 55   | 60   |
| 65                              | 7.0  | 8.0 | 9.0 | 10.0 | 11.0 | 11.5 |
| 70                              | 4.0  | 4.5 | 5.0 | 5.5  | 6.0  | 6.5  |
| 75                              | 1.0  | 1.0 | 1.0 | 1.0  | 1.0  | 1.0  |

#### 8.1.2 Resetting the remaining burner anti-cycling time

- ▶ Press and hold the reset button for more than three seconds.  
◀ ⚡ is shown in the display.

## 9 Handing the product over to the end user

- ▶ When you have finished the installation, attach the sticker supplied (in the end user's language) to the product cover.
- ▶ Explain to the end user how the safety devices work and where they are located.
- ▶ Inform the end user how to handle the product.
- ▶ In particular, draw attention to the safety information which the end user must follow.
- ▶ Inform the end user that they must have the product maintained in accordance with the specified intervals.
- ▶ Instruct the end user about measures taken for routing the combustion air supply and flue system.

## 10 Troubleshooting

### 10.1 Rectifying faults

- ▶ If fault codes (**F.XX**) are present, refer to the table in the appendix for advice or use the check programme(s). Overview of fault codes (→ Page 33)  
Installer level – Overview (→ Page 27)

If several faults occur at the same time, the display shows the corresponding fault messages for two seconds each in alternation.

- ▶ Press and hold the reset button for more than three seconds.
- ▶ If you are unable to clear the fault code and it reappears despite several reset attempts, contact customer service.

### 10.2 Procuring spare parts



The original components of the product were also certified by the manufacturer as part of the declaration of conformity. If you use other, non-certified or unauthorised parts during maintenance or repair work, this may void the conformity of the product and it will therefore no longer comply with the applicable standards.

We strongly recommend that you use original spare parts from the manufacturer as this guarantees fault-free and safe operation of the product. To receive information about the available original spare parts, contact the contact address provided on the reverse of these instructions.

- ▶ If you require spare parts for maintenance or repair work, use only the spare parts that are permitted for the product.

### 10.3 Calling up the fault memory

The last 10 fault messages are stored in the fault memory.

- ▶ Navigate to the **Fault list** menu.
  - ◀ The display shows the number of faults that have occurred, the fault numbers and the corresponding plain text display.
- ▶ Press  or  to call up individual fault messages.

### 10.4 Deleting the fault memory

1. Navigate to the **Fault list** menu.
2. Press  twice to delete the fault list.

### 10.5 Preparing the repair work

1. Decommission the product.
2. Disconnect the product from the electrical installation.
3. Remove the front casing.
4. Close the gas stopcock.
5. Close the service valves in the heating flow and in the heating return.
6. Close the service valve in the cold water pipe.
7. Drain the product if you want to replace water-bearing components of the product.
8. Make sure that water does not drip on live components (e.g. the electronics box).
9. Use only new seals and O-rings. Do not use any additional components.

### 10.6 Replacing defective components

#### 10.6.1 Replacing the burner

1. Remove the gas-air mixture unit. (→ Page 23)
2. Remove the burner seal.
3. Remove the burner.
4. Install the new burner complete with new seal on the heat exchanger.
5. Install the gas-air mixture unit. (→ Page 25)

#### 10.6.2 Replacing the gas-air mixture unit

1. Remove the gas-air mixture unit. (→ Page 23)
2. Install the new gas-air mixture (→ Page 25).

#### 10.6.3 Replacing the heat exchanger

1. Remove the side section. (→ Page 9)
2. Remove the gas-air mixture unit. (→ Page 23)

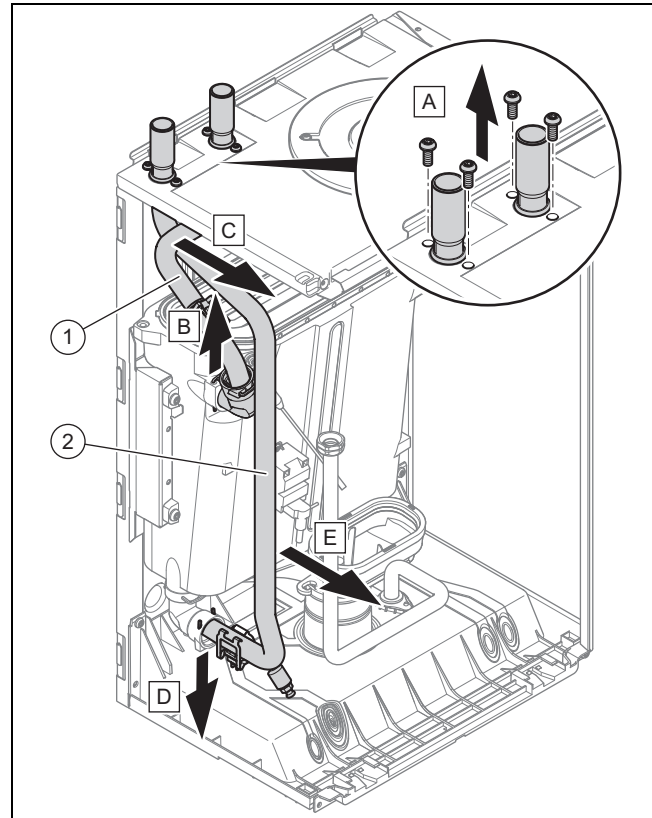

3. Remove the flow pipe (1).
4. Remove the return pipe (2).

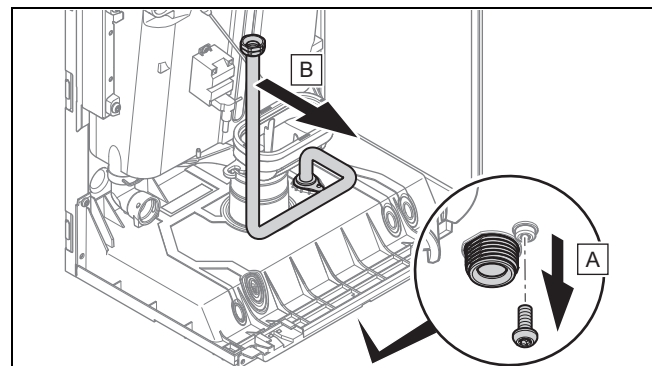

5. Remove the gas pipe.

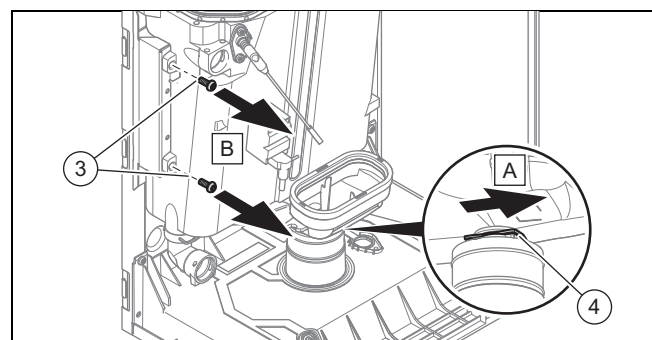

6. Undo the clip underneath the condensate tray (4).
7. Undo the two screws (3).

## 11 Inspection and maintenance

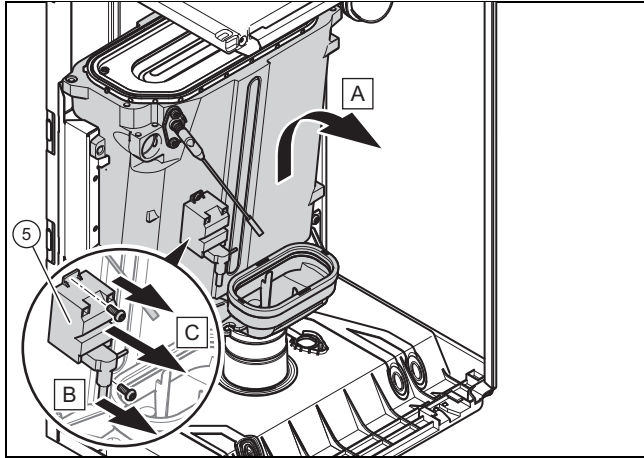

8. Lift the heat exchanger up slightly and remove it together with the condensate tray.
9. Remove the ignition transformer (5).
10. Replace all the seals.
11. Install the new heat exchanger in reverse order.

### 10.6.4 Replacing the main PCB

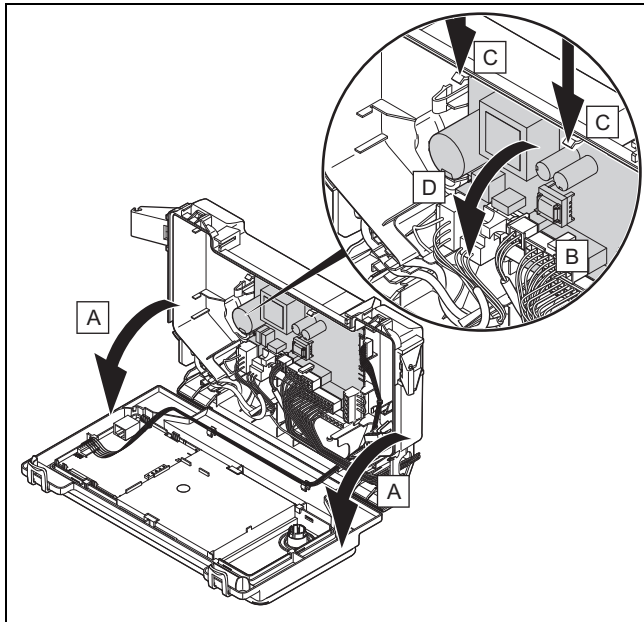

1. Open the electronics box. (→ Page 13)
2. Pull all of the plugs out from the PCB.
3. Undo the clips on the PCB.
4. Remove the PCB.
5. Install the new PCB in such a way that it clicks into the groove at the bottom and into the clip at the top.
6. Plug in the PCB plugs.
7. Close the electronics box.

### 10.6.5 Replacing the PCB for the user interface

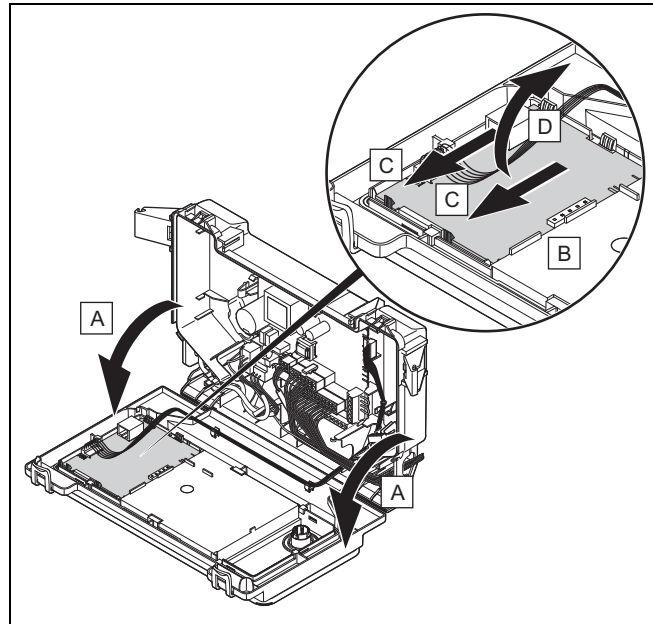

1. Open the electronics box. (→ Page 13)
2. Pull the plug out of the PCB.
3. Undo the clips on the PCB.
4. Remove the PCB.
5. Install the new PCB in such a way that it clicks into the groove at the bottom and into the clip at the top.
6. Plug in the PCB plug.
7. Close the electronics box.

### 10.7 Checking the product for leak-tightness

- ▶ Check that the product is leak-tight. (→ Page 19)

## 11 Inspection and maintenance

### 11.1 Using original seals

If you replace components, use only the enclosed original seals; additional sealing materials are not required.

### 11.2 Observing inspection and maintenance intervals

- ▶ Adhere to the minimum inspection and maintenance intervals. The inspection may require maintenance to be carried out earlier, depending on the results.
  - Inspection and maintenance work (→ Appendix)

### 11.3 Checking the CO<sub>2</sub> content

1. Start up the product with check programme (P.01). Installer level – Overview (→ Page 27)
2. Wait until the value that is read is stable.
  - Waiting period for reading a stable value: 5 min

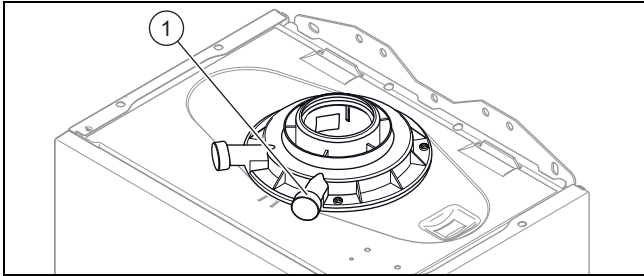

3. Unscrew the cover from the flue gas analysis point (1).
4. Measure the CO<sub>2</sub> content at the flue gas analysis point (1).
5. Compare the measured value with the corresponding value in the table.

### Checking the CO<sub>2</sub> content

| Great Britain    |                 |
|------------------|-----------------|
| front casing off | front casing on |
| Liquid gas       | Liquid gas      |
| G31              | G31             |
| 10.1 ±1.0 %      | 10.3 ±1.0 %     |

- ◁ The value is OK.
- ▽ The value is not OK; you cannot start up the product.
  - ▶ Set the CO<sub>2</sub> content. (→ Page 23)

### 11.4 Setting the CO<sub>2</sub> content

**Conditions:** The CO<sub>2</sub> content must be adjusted

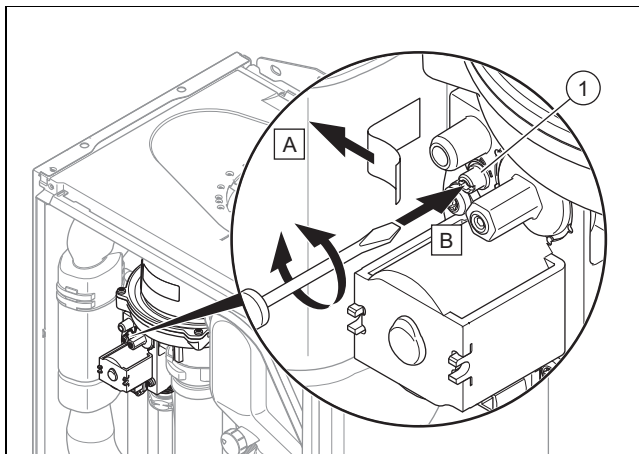

- ▶ Remove the sticker.
- ▶ Turn the screw (1) to set the CO<sub>2</sub> content (value with front casing removed).
  - ◁ To increase the CO<sub>2</sub> content: Turn anti-clockwise
  - ◁ To decrease the CO<sub>2</sub> content: Turn clockwise
- ▶ Only carry out the adjustment in increments of 1/8 turn and wait approximately 1 minute after each adjustment until the value has stabilised.
- ▶ Compare the measured value with the corresponding value in the table.

### Setting the CO<sub>2</sub> value

|                                    | Great Britain             |                           |
|------------------------------------|---------------------------|---------------------------|
|                                    | front casing off          | front casing on           |
|                                    | Liquid gas                | Liquid gas                |
|                                    | G31                       | G31                       |
| CO <sub>2</sub> at full load       | 10.1 ±1 %                 | 10.3 ±1 %                 |
| Set for Wobbe index W <sub>0</sub> | 21.34 kW-h/m <sup>3</sup> | 21.34 kW-h/m <sup>3</sup> |
| O <sub>2</sub> at full load        | 5.1 ±0.8 vol. %           | 5.1 ±0.8 vol. %           |
| CO at full load                    | ≤ 250 ppm                 | ≤ 250 ppm                 |
| CO/CO <sub>2</sub>                 | ≤ 0.0031                  | ≤ 0.0031                  |

- ▽ If the setting is not in the specified adjustment range, you must not start up the product.
  - ▶ Inform Customer Service.
- ▶ Check whether the air-quality requirements with regard to carbon monoxide are fulfilled.
- ▶ Fit the front panel.

### 11.5 Removing the gas-air mixture unit



#### Note

The gas-air mixture unit consists of three main components:

- Ventilator
- Gas valve
- Burner cover

1. Switch off the product via the main switch.
2. Close the gas isolator cock.
3. Remove the front casing. (→ Page 9)

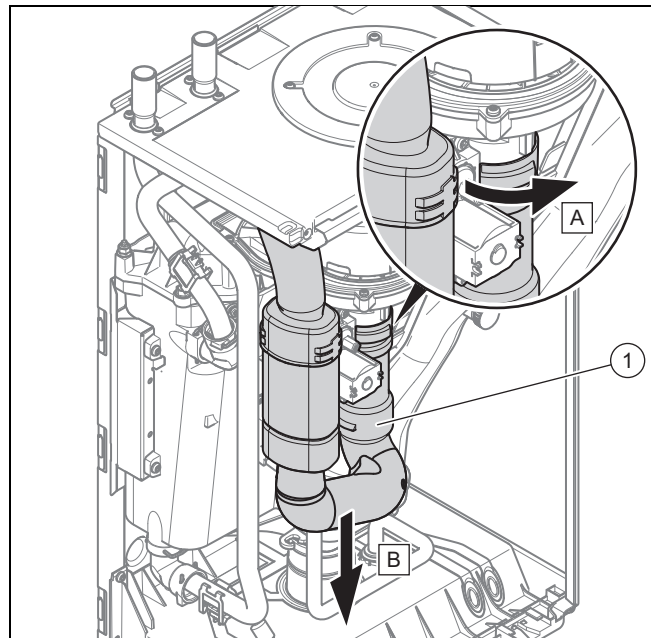

4. Remove the air intake pipe (1).

# 11 Inspection and maintenance

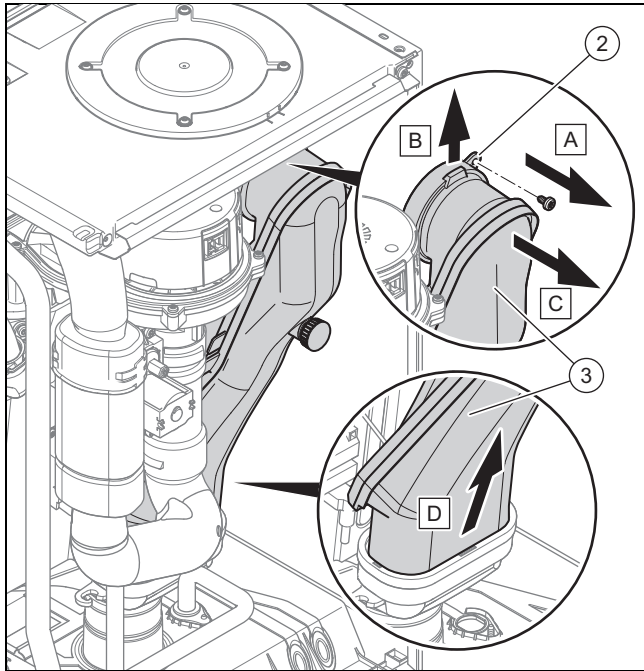

5. Push the clip (2) upwards.
6. Remove the flue pipe (3).

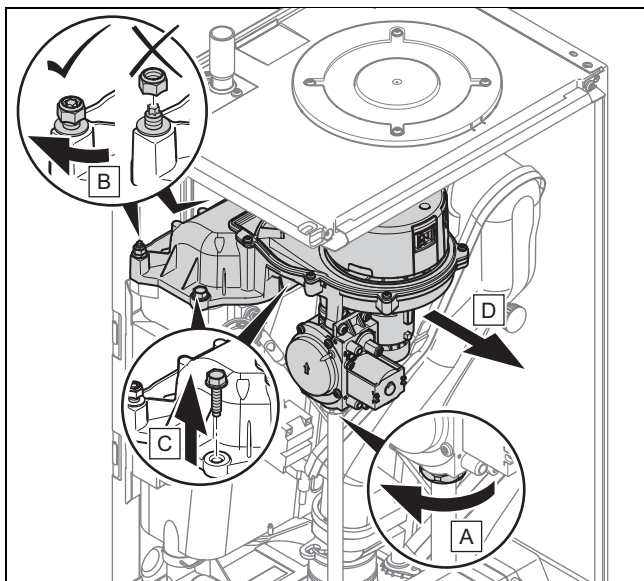

7. Remove the plugs from the gas valve.
8. Remove the gas-air mixture unit.
9. Remove both burner seals from the burner cover.

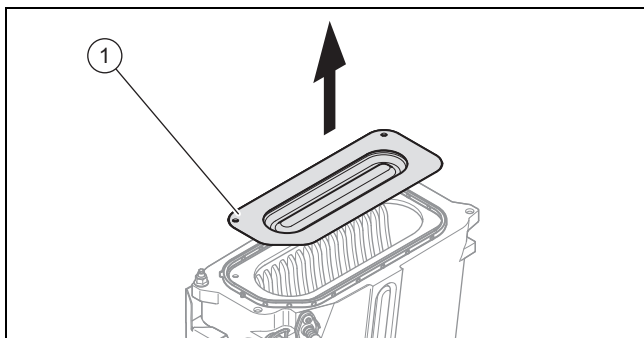

10. Remove the burner (4).

## 11.6 Cleaning the heat exchanger

1. Check the heat exchanger for damage and dirt.
2. If required, clean and replace the heat exchanger.
3. Protect the folded down electronics box against sprayed water.

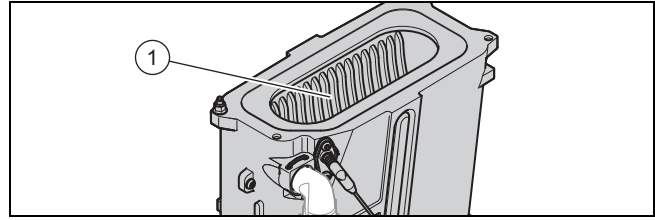

4. Clean the ribs of the heat exchanger (1) with water.
  - ◁ The water runs out via the condensate tray.

## 11.7 Checking the burner

- ▶ Check the surface of the burner for damage. If you see any damage, replace the burner.

## 11.8 Checking the ignition electrode

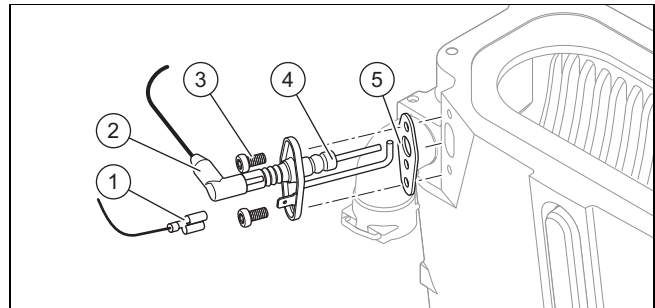

1. Disconnect the connection (2) and the earthing cable (1).
2. Remove the fixing screws (3).
3. Carefully remove the electrode from the combustion chamber.
4. Check that the electrode ends (4) are undamaged.
5. Check the electrode distance.
  - Clearance for the ignition electrodes: 3.5 ... 4.5 mm
6. Make sure that the seal (5) is free from damage.
  - ▽ If necessary, replace the seal.



### 11.9 Cleaning the condensate trap

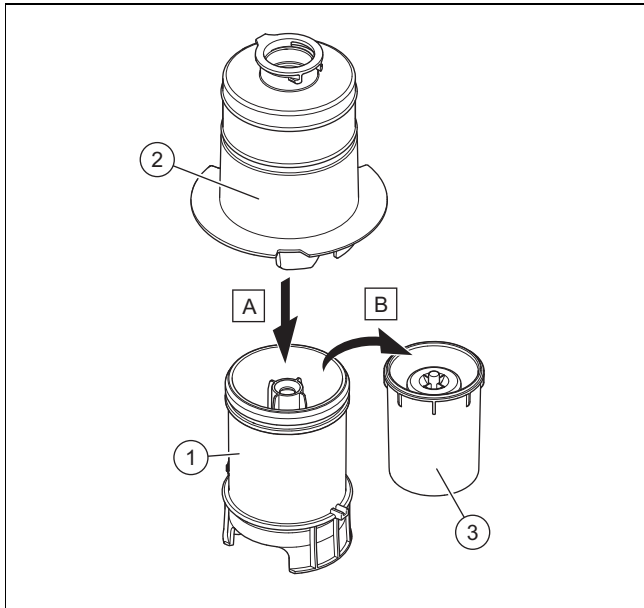

1. Unclip the lower section of the condensate trap (1) from the upper section of the condensate trap (2).
2. Remove the float (3).
3. Flush out the lower section of the condensate trap with water.
4. Re-insert the float (3).



#### Note

Check whether the float is present in the condensate trap.

5. Clip the lower section of the condensate trap (1) into the upper section of the condensate trap (2).

### 11.10 Installing the gas-air mixture unit

1. Install the burner.
2. Install two new burner seals in the burner hood.
3. Install the gas-air mixture unit.
4. Tighten the screws on the gas-air mixture unit.
  - Ideally to 7 Nm if a torque spanner is available.
5. Install the flue pipe.
6. Install the air intake pipe.

### 11.11 Draining the product

1. Close the service valves of the product.
2. Start check programme **P.06**.
3. Open the drain valves.
4. Make sure that the air vent cap on the internal pump is open so that the product can be drained fully.

### 11.12 Completing inspection and maintenance work

1. Check the gas connection pressure (gas flow pressure). (→ Page 18)
2. Check the CO<sub>2</sub> content. (→ Page 22)

### 11.13 Checking the product for leak-tightness

- ▶ Check that the product is leak-tight. (→ Page 19)

## 12 Decommissioning the product

- ▶ Switch off the product.
- ▶ Disconnect the product from the electrical installation.
- ▶ Close the gas stopcock.
- ▶ Close the cold-water isolation valve.

## 13 Recycling and disposal

### Disposing of the packaging

- ▶ Dispose of the packaging correctly.
- ▶ Observe all relevant regulations.

## 14 Customer service

To ensure regular servicing, it is strongly recommended that arrangements are made for a Maintenance Agreement. Please contact Vaillant Service Solutions for further details:

Telephone: 0330 100 3461

# Appendix

## Appendix

### A Inspection and maintenance work

The table below lists the manufacturer requirements with respect to minimum inspection and maintenance intervals. If national regulations and directives require shorter inspection and maintenance intervals, you should observe these instead of the intervals listed. Each time inspection and maintenance work is carried out, carry out the required preparatory and completion work.



#### Note

Note: For products that are not part of the annual service agreement, maintenance must be carried out at least once every five years.

| #  | Maintenance work  | Interval                            |    |
|----|---|-------------------------------------|----|
| 1  | Ask the end user whether any significant problems occur when operating the product  | Annually                            |    |
| 2  | Use the diagnostics system to check the product's fault history   | Annually                            |    |
| 3  | Visually inspect whether the air/flue pipe and its opening have been installed correctly in accordance with the set-up instructions   | Annually                            |    |
| 4  | Check that the unit has been installed correctly and the connections have been secured  | Annually                            |    |
| 5  | Check all of the connections for tightness  | Annually                            |    |
| 6  | Check that the condensate pipe is in good condition, that it is leak-tight and that the drain is correct  | Annually                            |    |
| 7  | Check whether all of the externally routed condensate pipes are dimensioned correctly and have been insulated sufficiently (frost protection)   | Annually                            |    |
| 8  | Check whether the gas flow rate corresponds with the specifications on the data plate and lies within the tolerances specified in these instructions  | Annually                            |    |
| 9  | If the gas flow rate lies outside of the tolerances specified in these instructions, eliminate the fault in accordance with the regulations and the current technology  | Annually                            |    |
| 10 | Check the general condition of the product and, if required, eliminate any faults that are found  | Annually                            |    |
| 11 | Carry out the combustion analysis: Measure the CO content, CO <sub>2</sub> content and the CO/CO <sub>2</sub> ratio. For products with a rear air/flue connection: The combustion analysis can only be carried out when the unit casing has been removed; it is not necessary to test these products for flue gas recirculation | Annually                            |    |
| 12 | Check the product's recirculation at the supply air test point on the air/flue pipe. If required, inspect the entire air/flue system and, if necessary, correct the fault   | Annually                            |    |
| 13 | Disconnect the product from the electrical installation   | Annually                            |    |
| 14 | Check and, if required, correct the electrical installation   | Annually                            |    |
| 15 | Remove the unit casing, check the condition of all of the functional components, in particular for leaks, corrosion, rust, etc. and, if required, repair any damage   | Annually                            |    |
| 16 | Visual inspection of the heat exchanger and burner seals  | Annually                            |    |
| 17 | Carefully clean the inside of the product: The air passages to the burner must be clear and clean   | Annually                            |    |
| 18 | Close the installation's gas stopcock and, if required, service valves  | Annually                            |    |
| 19 | Check the quality of the heating water: Clarity (clouding), correct inhibitor and pH value  | Annually                            |    |
| 20 | Removing the gas-air mixture unit   | If required, at least every 5 years | 23 |
| 21 | Checking the burner   | If required, at least every 5 years | 24 |
| 22 | Cleaning the condensate trap  | Annually                            | 25 |
| 23 | Filling the condensate trap   | Annually                            | 18 |
| 24 | Cleaning the heat exchanger   | If required, at least every 5 years | 24 |

| #  | Maintenance work  | Interval  |  |
|----|---|---|---|
| 25 | Check and, if required, replace the insulating mat in the burner area   | If required, at least every 5 years             |   |
| 26 | Installing the gas-air mixture unit   | If required, at least every 5 years             | 25  |
| 27 | Reassemble the product  | After each time maintenance work is carried out |   |
| 28 | Open the service valves, carry out the required leak-tightness test   | Annually  |   |
| 29 | Fill the product/heating installation to the filling pressure specified for the system  | Annually  |   |
| 30 | Connect the product to the electrical installation  | Annually  |   |
| 31 | Run the test operation on the product/heating installation including hot water generation (if available) and, if required, purge the product/heating installation | Annually  |   |
| 32 | Record all of the analysis results in the Benchmark service record in these instructions  | Annually  |   |

## B Installer level – Overview

| Setting level  | Values        |      | Unit | Increment, select, explanation  | Default setting |
|--|---------------|------|------|---|-----------------|
|  | Min.          | Max. |      |   |                 |
| <b>Installer level →</b>   |               |      |      |   |                 |
| Enter code   | 00            | 99   | –    | 1 (competent person code 17)  | –               |
| <b>Installer level → List of faults →</b>  |               |      |      |   |                 |
| F.XX - F.XX <sup>1</sup>   | Current value |      | –    | –   | –               |
| <b>Installer level → Test programs →</b>   |               |      |      |   |                 |
| Gas type check   | Current value |      | –    | Liquid gas, natural gas   | –               |
| <b>Installer level → Test programs → Check programs →</b>                                      |               |      |      |   |                 |
| P.00 Purging   | –             | –    | –    | Yes, No   | –               |
| P.01 Maximum load  | –             | –    | –    | Yes, No   | –               |
| P.02 Minimum load  | –             | –    | –    | Yes, No   | –               |
| P.06 Filling mode  | –             | –    | –    | Yes, No   | –               |
| <b>Installer level → Test programs → Function menu →</b>                                       |               |      |      |   |                 |
| T.02 3-way valve   | –             | –    | –    | On, Off   | –               |
| T.03 Fan   | –             | –    | –    | On, Off   | –               |
| T.04 Cyl. charging pump  | –             | –    | –    | On, Off   | –               |
| T.05 Circulation pump  | –             | –    | –    | On, Off   | –               |
| T.06 External pump   | –             | –    | –    | On, Off   | –               |
| T.08 Burner  | –             | –    | –    | On, Off   | –               |
| <b>Installer level → Test programs → Electronics self-test →</b>                               |               |      |      |   |                 |
| Self-test  | –             | –    | –    | Yes, No   | –               |
| <b>Installer level → Appliance config. →</b>   |               |      |      |   |                 |
| Language   | –             | –    | –    | Deutsch, English, Français, Italiano, Dansk, Nederlands, Castellano, Türkçe, Magyar, Русский, Українська, Svenska, Norsk, Polski, Čeština, Hrvatski, Slovenčina, Română, Slovenščina, Português, Srpski | English         |
| <sup>1</sup> Fault lists are only displayed, and can only be deleted, if faults have occurred. |               |      |      |   |                 |

## Appendix

| Setting level  | Values        |      | Unit | Increment, select, explanation  | Default setting |
|--|---------------|------|------|---|-----------------|
|  | Min.          | Max. |      |   |                 |
| Flow temp. setpoint  | 30            | 75   | °C   | 1   | –               |
| DHW temperature  | 30            | 60   | °C   | 1<br>Product with connected domestic hot water cylinder   | –               |
| Auxiliary relay  | 1             | 10   | –    | 1 = Circulation pump<br>2 = External pump<br>3 = Cylinder charging pump<br>4 = Extractor hood<br>5 = External solenoid valve<br>6 = External fault message<br>7 = Solar pump (not active)<br>8 = eBUS remote control (not active)<br>9 = Legionella protection pump (not active)<br>10 = Solar valve (not active) | 2               |
| Accessory relay 1  | 1             | 10   | –    | 1 = Circulation pump<br>2 = External pump<br>3 = Cylinder charging pump<br>4 = Extractor hood<br>5 = External solenoid valve<br>6 = External fault message<br>7 = Solar pump (not active)<br>8 = eBUS remote control (not active)<br>9 = Legionella protection pump (not active)<br>10 = Solar valve (not active) | 2               |
| Accessory relay 2  | 1             | 10   | –    | 1 = Circulation pump<br>2 = External pump<br>3 = Cylinder charging pump<br>4 = Extractor hood<br>5 = External solenoid valve<br>6 = External fault message<br>7 = Solar pump (not active)<br>8 = eBUS remote control (not active)<br>9 = Legionella protection pump (not active)<br>10 = Solar valve (not active) | 2               |
| Heating partial load   | –             | –    | kW   | Partial load only, full load only, auto   | Auto            |
| Contact data   | Phone number  | –    | –    | 0 – 9   | Auto            |
| Default setting  | –             | –    | –    | On, Off   | –               |
| <b>Installer level → Diagnostics menu →</b>  |               |      |      |   |                 |
| D.XXX - D.XXX  | Current value | –    | –    | –   | –               |
| <b>Installer level → Start ins. assistant →</b>                                    |               |      |      |   |                 |
| Language   | –             | –    | –    | Deutsch, English, Français, Italiano, Dansk, Nederlands, Castellano, Türkçe, Magyar, Русский, Українська, Svenska, Norsk, Polski, Čeština, Hrvatski, Slovenčina, Română, Slovenščina, Português, Srpski   | English         |
| Filling mode: 3-way valve is in mid-position                                       | 0             | 2    | –    | 0 = Normal operating mode<br>1 = Mid-position (parallel operation)<br>2 = Permanent heating mode position   | –               |
| Purge programme  | –             | –    | –    | Automatic adaptive purging of the heating circuit and hot water circuit<br>Not active<br>Active   | –               |
| *Fault lists are only displayed, and can only be deleted, if faults have occurred. |               |      |      |   |                 |

| Setting level                   | Values       |      | Unit | Increment, select, explanation  | Default setting |
|---------------------------------|--------------|------|------|---|-----------------|
|                                 | Min.         | Max. |      |   |                 |
| Flow temp. setpoint             | 30           | 75   | °C   | 1   | –               |
| DHW temperature                 | 35           | 60   | °C   | 1<br>Product with hot water generation  | –               |
| Auxiliary relay                 | 1            | 10   | –    | 1 = Circulation pump<br>2 = External pump<br>3 = Cylinder charging pump<br>4 = Extractor hood<br>5 = External solenoid valve<br>6 = External fault message<br>7 = Solar pump (not active)<br>8 = eBUS remote control (not active)<br>9 = Legionella protection pump (not active)<br>10 = Solar valve (not active) | 2               |
| Accessory relay 1               | 1            | 10   | –    | 1 = Circulation pump<br>2 = External pump<br>3 = Cylinder charging pump<br>4 = Extractor hood<br>5 = External solenoid valve<br>6 = External fault message<br>7 = Solar pump (not active)<br>8 = eBUS remote control (not active)<br>9 = Legionella protection pump (not active)<br>10 = Solar valve (not active) | 2               |
| Accessory relay 2               | 1            | 10   | –    | 1 = Circulation pump<br>2 = External pump<br>3 = Cylinder charging pump<br>4 = Extractor hood<br>5 = External solenoid valve<br>6 = External fault message<br>7 = Solar pump (not active)<br>8 = eBUS remote control (not active)<br>9 = Legionella protection pump (not active)<br>10 = Solar valve (not active) | 2               |
| Contact data                    | Phone number |      | –    | 0-9   | –               |
| End the installation assistant? | –            | –    | –    | Yes, No   | –               |

\*Fault lists are only displayed, and can only be deleted, if faults have occurred.

## C Overview of diagnostics codes

| Setting level   | Values        |      | Unit | Increment, select, explanation  | Default setting            | Own setting    |
|---|---------------|------|------|---|----------------------------|----------------|
|   | Min.          | Max. |      |   |                            |                |
| d.00 Heating maximum output                                     | –             | –    | kW   | The maximum heating output varies depending on the product.<br>→ Section "Technical data" | → Section "Technical data" | Adjustable     |
| d.01 Pump overrun in heating mode                               | 1             | 60   | min  | 1   | 5                          | Adjustable     |
| d.02 Burner anti-cycling time in heating mode                   | 2             | 60   | min  | 1   | 20                         | Adjustable     |
| d.04 Water temperature in the cylinder                          | Current value |      | °C   | –   | –                          | Not adjustable |
| d.05 Determined heating flow set target temperature             | Current value |      | °C   | –   | –                          | Not adjustable |
| d.07 Set target temperature for the domestic hot water cylinder | Current value |      | °C   | –   | –                          | Not adjustable |

## Appendix

| Setting level   | Values        |      | Unit | Increment, select, explanation  | Default setting | Own setting    |
|---|---------------|------|------|---|-----------------|----------------|
|   | Min.          | Max. |      |   |                 |                |
| <b>d.08 Status of the 230 V thermostat</b>  | Current value |      | –    | 0 = Room thermostat open (no heat requirement)<br>1 = Room thermostat closed (heat requirement)   | –               | Not adjustable |
| <b>d.09 Heating flow set target temperature that is set on the eBUS room thermostat</b>                               | Current value |      | –    | –   | –               | Not adjustable |
| <b>d.10 Status of the internal pump in the heating circuit</b>  | Current value |      | –    | off / on  | –               | Not adjustable |
| <b>d.11 Status of the heating circuit's shunt pump</b>  | Current value |      | –    | off / on  | –               | Not adjustable |
| <b>d.13 Status of the hot water circuit's circulation pump</b>  | Current value |      | –    | off / on  | –               | Not adjustable |
| <b>d.16 Status of the 24 V room thermostat</b>  | Current value |      | –    | off = Heating off<br>on = Heating on  | –               | Not adjustable |
| <b>d.17 Heating control</b>   | –             | –    | –    | off = Flow temperature<br>on = Return temperature (adjustment for underfloor heating. If you have activated the return temperature control, the automatic heating output determination function is not active.)   | 0               | Adjustable     |
| <b>d.18 Pump overrun operating mode</b>   | 1             | 3    | –    | 1 = Comfort (continuously operating pump)<br>3 = Eco (intermittent pump mode – for the dissipation of the residual heat after hot water generation at an extremely low heat demand)   | 1               | Adjustable     |
| <b>d.20 Maximum hot water set target temperature</b>  | 50            | 60   | °C   | 1   | 50              | Adjustable     |
| <b>d.23 Status of the heating demand</b>  | Current value |      | –    | off = Heating off (Summer mode)<br>on = Heating on  | –               | Not adjustable |
| <b>d.24 Status of the pressure monitor</b>  | 0             | 1    | –    | off = Not switched<br>on = Switched   | –               | Not adjustable |
| <b>d.25 Status of the requirement to reheat the cylinder or for the hot water warm start from the eBUS thermostat</b> | Current value |      | –    | off = Function deactivated<br>on = Function activated   | –               | Not adjustable |
| <b>d.27 Function of relay 1 (multi-functional module)</b>   | 1             | 10   | –    | 1 = Circulation pump<br>2 = External pump<br>3 = Cylinder charging pump<br>4 = Extractor hood<br>5 = External solenoid valve<br>6 = External fault message<br>7 = Solar pump (omitted)<br>8 = eBUS remote control<br>9 = Legionella protection pump<br>10 = Solar valve | 1               | Adjustable     |
| <b>d.28 Function of relay 2 (multi-functional module)</b>   | 1             | 10   | –    | 1 = Circulation pump<br>2 = External pump<br>3 = Cylinder charging pump<br>4 = Extractor hood<br>5 = External solenoid valve<br>6 = External fault message<br>7 = Solar pump (omitted)<br>8 = eBUS remote control<br>9 = Legionella protection pump<br>10 = Solar valve | 2               | Adjustable     |
| <b>d.31 Automatic filling device</b>  | 0             | 2    | –    | 0 = Manual<br>1 = Semi-automatic<br>2 = Automatic   | 0               | Adjustable     |

| Setting level  | Values        |      | Unit | Increment, select, explanation   | Default setting | Own setting    |
|--|---------------|------|------|--|-----------------|----------------|
|  | Min.          | Max. |      |  |                 |                |
| d.33 Fan speed target value                                  | Current value |      | rpm  | Fan speed = Display value x 100  | –               | Not adjustable |
| d.34 Value for the fan speed                                 | Current value |      | rpm  | Fan speed = Display value x 100  | –               | Not adjustable |
| d.40 Heating flow temperature                                | Current value |      | °C   | –  | –               | Not adjustable |
| d.41 Heating return temperature                              | Current value |      | °C   | –  | –               | Not adjustable |
| d.43 Heating curve   | 0.2           | 4    | –    | 0.1  | 1.2             | Adjustable     |
| d.45 Value for the base point of the heating curve           | 15            | 30   | –    | 1  | 20              | Adjustable     |
| d.47 Outside temperature                                     | Current value |      | °C   | –  | –               | Not adjustable |
| d.50 Correction of the minimum fan speed                     | 0             | 3000 | rpm  | 1<br>Fan speed = Display value x 10  | 600             | Adjustable     |
| d.51 Correction of the maximum fan speed                     | -2500         | 0    | rpm  | 1<br>Fan speed = Display value x 10  | -1000           | Adjustable     |
| d.58 Solar circuit reheating                                 | 0             | 3    | –    | 0 = Boiler's Legionella protection function deactivated<br>3 = Hot water activated (target value min. 60 °C) | 0               | Adjustable     |
| d.60 Number of blocks by the temperature sensor              | Current value |      | –    | –  | –               | Not adjustable |
| d.61 Number of successful ignitions                          | Current value |      | –    | –  | –               | Not adjustable |
| d.62 Night set-back  | 0             | 30   | –    | 1  | 0               | Adjustable     |
| d.64 Average burner ignition time                            | Current value |      | s    | –  | –               | Not adjustable |
| d.65 Maximum burner ignition time                            | Current value |      | s    | –  | –               | Not adjustable |
| d.66 Activation of the warm start function for hot water     | –             | –    | –    | off = Function deactivated<br>on = Function activated  | 1               | Adjustable     |
| d.67 Remaining burner anti-cycling time (setting under d.02) | Current value |      | min  | –  | –               | Not adjustable |
| d.68 Number of unsuccessful ignitions at 1st attempt         | Current value |      | –    | –  | –               | Not adjustable |
| d.69 Number of unsuccessful ignitions at 2nd attempt         | Current value |      | –    | –  | –               | Not adjustable |
| d.71 Maximum heating flow set target temperature             | 45            | 80   | °C   | 1  | 75              | Adjustable     |
| d.75 Maximum cylinder reheating time                         | 20            | 90   | min  | 1  | 45              | Adjustable     |
| d.77 Max. cylinder reheating                                 | –             | –    | kW   | 1<br>→ Section "Technical data"  | –               | Adjustable     |
| d.78 DHW max. flow temperature                               | 50            | 80   | °C   | 1  | –               | Adjustable     |
| d.80 Running time in heating mode                            | Current value |      | h    | –  | –               | Not adjustable |
| d.81 Running time in DHW mode                                | Current value |      | h    | –  | –               | Not adjustable |
| d.82 Number of burner ignitions in heating mode              | Current value |      | –    | Number of ignitions = Display value x 100  | –               | Not adjustable |
| d.83 Number of burner ignitions in DHW mode                  | Current value |      | –    | Number of ignitions = Display value x 100  | –               | Not adjustable |
| d.84 Maintenance in  | 0             | 3000 | h    | Number of hours = Display value x 10   | 300             | Not adjustable |
| d.85 Increase in the min. output (heating and DHW mode)      | –             | –    | kW   | 1<br>→ Section "Technical data"  | –               | Adjustable     |

## Appendix

| Setting level                                  | Values  |      | Unit | Increment, select, explanation        | Default setting | Own setting    |
|--|---|------|------|---------------------------------------|-----------------|----------------|
|  | Min.  | Max. |      |                                       |                 |                |
| <b>d.90 Status of the eBUS room thermostat</b> | Current value                                   |      | –    | off = Not connected<br>on = Connected | –               | Not adjustable |
| <b>d.93 Setting the product code</b>           | 0   | 99   | –    | 1                                     | –               | Adjustable     |
| <b>d.94 Delete fault list</b>                  | 0   | 1    | –    | off = No<br>on = Yes                  | –               | Adjustable     |
| <b>d.95 Software versions</b>                  | –   | –    | –    | 1 = Main PCB<br>2 = Interface PCB     | –               | Adjustable     |
| <b>d.96 Reset to factory setting</b>           | –   | –    | –    | 0 = No<br>1 = Yes                     | –               | Adjustable     |
| <b>d.128 Heating minimum target value</b>      | 10  | 75   | °C   | 1                                     | 10              | Adjustable     |
| <b>d.129 Hot water minimum target value</b>    | 35<br>(combination unit)<br>45<br>(pure boiler) | 60   | °C   | 1                                     | 35              | Adjustable     |

## D Status codes – Overview

| Status code   | Meaning   |
|---|---|
| <b>Displays in heating mode</b>                         |   |
| <b>S. 0</b>   | Heating mode: No requirement  |
| <b>S.01</b>   | Heating mode: Advance fan operation   |
| <b>S.02</b>   | Heating mode: Pump pre-run  |
| <b>S.03</b>   | Heating mode: Burner ignition   |
| <b>S.04</b>   | Heating mode: Burner on   |
| <b>S.05</b>   | Heating mode: Pump/fan overrun  |
| <b>S.06</b>   | Heating mode: Fan overrun   |
| <b>S.07</b>   | Heating mode: Pump overrun  |
| <b>S.08</b>   | Heating mode: Temporary shutdown after heating procedure  |
| <b>Display in hot water handling mode with cylinder</b> |   |
| <b>S.20</b>   | Hot water handling mode: Requirement  |
| <b>S.21</b>   | Hot water handling mode: Advance fan operation  |
| <b>S.22</b>   | Hot water handling mode: Pump pre-run   |
| <b>S.23</b>   | Hot water handling mode: Burner ignition  |
| <b>S.24</b>   | DHW mode: Burner on   |
| <b>S.25</b>   | DHW mode: Pump/fan overrun  |
| <b>S.26</b>   | DHW mode: Fan overrun   |
| <b>S.27</b>   | DHW mode: Pump overrun  |
| <b>S.28</b>   | Hot water handling mode: Temporary shutdown of the burner   |
| <b>Other displays</b>                                   |   |
| <b>S.30</b>   | Room thermostat is blocking heating mode.   |
| <b>S.31</b>   | No heating demand: Summer mode, eBUS controller, waiting period   |
| <b>S.32</b>   | Fan waiting time: Fan speed outside of the tolerance values   |
| <b>S.34</b>   | Frost protection active   |
| <b>S.39</b>   | Underfloor heating contact open   |
| <b>S.42</b>   | Flue non-return flap closed   |
| <b>S.46</b>   | Frost protection mode (Comfort): Minimum load   |
| <b>S.53</b>   | Product in waiting period/operation block function due to low water pressure (flow/return spread too large) |



| Status code | Meaning  |
|-------------|--|
| S.54        | Waiting period: Low water pressure in the circuit (flow/return spread too large) |
| S.88        | Product purging active   |
| S.91        | Maintenance: Demo mode   |
| S.96        | Automatic test programme: Return temperature sensor, heating demands blocked.    |
| S.98        | Automatic test programme: Return temperature sensor, heating demands blocked.    |
| S.99        | Internal automatic test programmes   |
| S.108       | Purging the combustion chamber, fan in operation                                 |
| S.109       | Product's standby mode activated   |

## E Overview of fault codes

| Code | Meaning   | Cause   |
|------|---|---|
| F.00 | Flow temperature sensor interruption                | NTC plug not plugged in or has come loose, multiple plug on the PCB not plugged in correctly, interruption in cable harness, NTC defective  |
| F.01 | Return temperature sensor interruption              | NTC plug not plugged in or has come loose, multiple plug on the PCB not plugged in correctly, interruption in cable harness, NTC defective  |
| F.10 | Flow NTC short circuit                              | NTC defective, short circuit in cable harness, cable/casing   |
| F.11 | Return NTC short circuit                            | NTC defective, short circuit in cable harness, cable/casing   |
| F.13 | Warm start sensor/cylinder sensor short circuit     | NTC defective, short circuit in cable harness, cable/casing   |
| F.22 | Safety switch-off: Low water pressure               | No or insufficient water in the product, water pressure sensor defective, cable to pump or water pressure sensor loose/not connected/defective  |
| F.23 | Safety switch-off: Temperature difference too great | Pump blocked, insufficient pump output, air in product, flow and return NTC connected the wrong way round   |
| F.24 | Safety switch-off: Temperature rise too fast        | Pump blocked, insufficient pump output, air in product, system pressure too low, non-return valve blocked/incorrectly installed   |
| F.25 | Safety switch-off: Flue gas temperature too high    | Break in plug connection for optional flue gas safety temperature limiter (STB), break in cable harness   |
| F.27 | Safety switch-off: Flame simulation                 | Moisture on the electronics, electronics (flame monitor) defective, gas solenoid valve leaking  |
| F.28 | Failure during start-up: Ignition unsuccessful      | Gas meter defective or gas pressure monitor has triggered, air in gas, gas flow pressure too low, thermal isolator device (TAE) has triggered, condensate duct blocked, incorrect gas restrictor, incorrect spare part gas valve, fault on the gas valve, multiple plug on PCB incorrectly plugged in, break in cable harness, ignition system (ignition transformer, ignition cable, ignition plug, ignition electrode) defective, ionisation current interrupted (cable, electrode), incorrect earthing of product, electronics defective |
| F.29 | Failure during operation: Re-ignition unsuccessful  | Gas supply temporarily stopped, flue gas recirculation, condensate duct blocked, defective earthing of product, ignition transformer has spark failure  |
| F.32 | Fan fault   | Plug on fan not correctly plugged in, multiple plug on PCB not correctly plugged in, break in cable harness, fan blocked, Hall sensor defective, electronics defective  |
| F.49 | Fault: eBUS   | Short circuit on eBUS, eBUS overload or two power supplies with different polarities on the eBUS  |
| F.61 | Fault: Gas valve regulation                         | <ul style="list-style-type: none"> <li>– Short circuit/short to earth in cable harness for the gas valve</li> <li>– Gas valve defective (coils shorted to earth)</li> <li>– Electronics defective</li> </ul>  |
| F.62 | Fault: Gas valve switch-off delay                   | <ul style="list-style-type: none"> <li>– Delayed shutdown of gas valve</li> <li>– Delayed extinguishing of flame signal</li> <li>– Gas valve leaking</li> <li>– Electronics defective</li> </ul>  |
| F.63 | Fault: EEPROM                                       | Electronics defective   |
| F.64 | Fault: Electronics/NTC                              | Flow or return NTC short circuited, electronics defective   |
| F.65 | Fault: Electronics temp.                            | Electronics overheating due to external influences, electronics defective   |
| F.67 | Fault: Electronics/flame                            | Implausible flame signal, electronics defective   |

## Appendix

| Code | Meaning  | Cause   |
|------|--|---|
| F.68 | Fault: Unstable flame signal                                     | Air in gas, gas flow pressure too low, incorrect air ratio, condensate duct blocked, incorrect gas restrictor, ionisation flow interruption (cable, electrode), flue gas recirculation, condensate duct   |
| F.70 | Invalid device specific number (DSN)                             | If spare parts fitted: Display and PCB replaced at same time and DSN not reset, incorrect or missing output range coding resistance   |
| F.71 | Flow NTC fault   | Flow temperature sensor signalling constant value: <ul style="list-style-type: none"> <li>– Flow temperature sensor incorrectly positioned at supply pipe</li> <li>– Flow temperature sensor defective</li> </ul>   |
| F.72 | Flow/return NTC fault  | Flow/return NTC temperature difference too great → flow and/or return temperature sensor defective  |
| F.73 | Water pressure sensor signal in the wrong range (too low)        | Interruption/short circuit of water pressure sensor, interruption/short circuit to GND in supply line to water pressure sensor or water pressure sensor defective   |
| F.74 | Water pressure sensor signal outside correct range (too high)    | Line to water pressure sensor has a short circuit to 5 V/24 V or internal fault in the water pressure sensor  |
| F.75 | Fault: No pressure change detection when starting pump           | Water pressure sensor and/or pump defective, air in the heating installation, insufficient water in the product; check adjustable bypass, connect external expansion vessel to the return   |
| F.76 | Overheating protection on primary heat exchanger has responded   | Cable or cable connections for safety fuse in primary heat exchanger or primary heat exchanger defective  |
| F.77 | Fault: Flue non-return flap/condensate pump                      | No response from flue non-return flap or condensate pump defective  |
| F.83 | Fault: Flow and/or return temperature sensor temperature change  | When the burner starts, the temperature change registered at the flow and/or return temperature sensor is non-existent or too small. <ul style="list-style-type: none"> <li>– Insufficient water in product</li> <li>– Flow or return temperature sensor not in correct position at pipe</li> </ul> |
| F.85 | Fault: Flow and return temperature sensors incorrectly installed | The flow and/or return temperature sensors have been installed on the same pipe/incorrect pipe  |
| F.87 | Ignition transformer not connected                               | Ignition transformer plug not plugged in or has come loose, multiple plug on the PCB not plugged in correctly, interruption in cable harness, electronics defective   |
| F.88 | Gas valve not connected  | Gas valve plug not plugged in or has come loose, multiple plug on the PCB not plugged in correctly, interruption in cable harness, electronics defective  |
| F.89 | Incorrect pump detected  | Unsuitable pump connected, PWM plug not plugged in or has come loose, multiple plug on the PCB not plugged in correctly, interruption in cable harness, electronics defective   |
| con  | No communication with the PCB                                    | Communication fault between display and PCB in the electronics box  |

F Wiring diagram

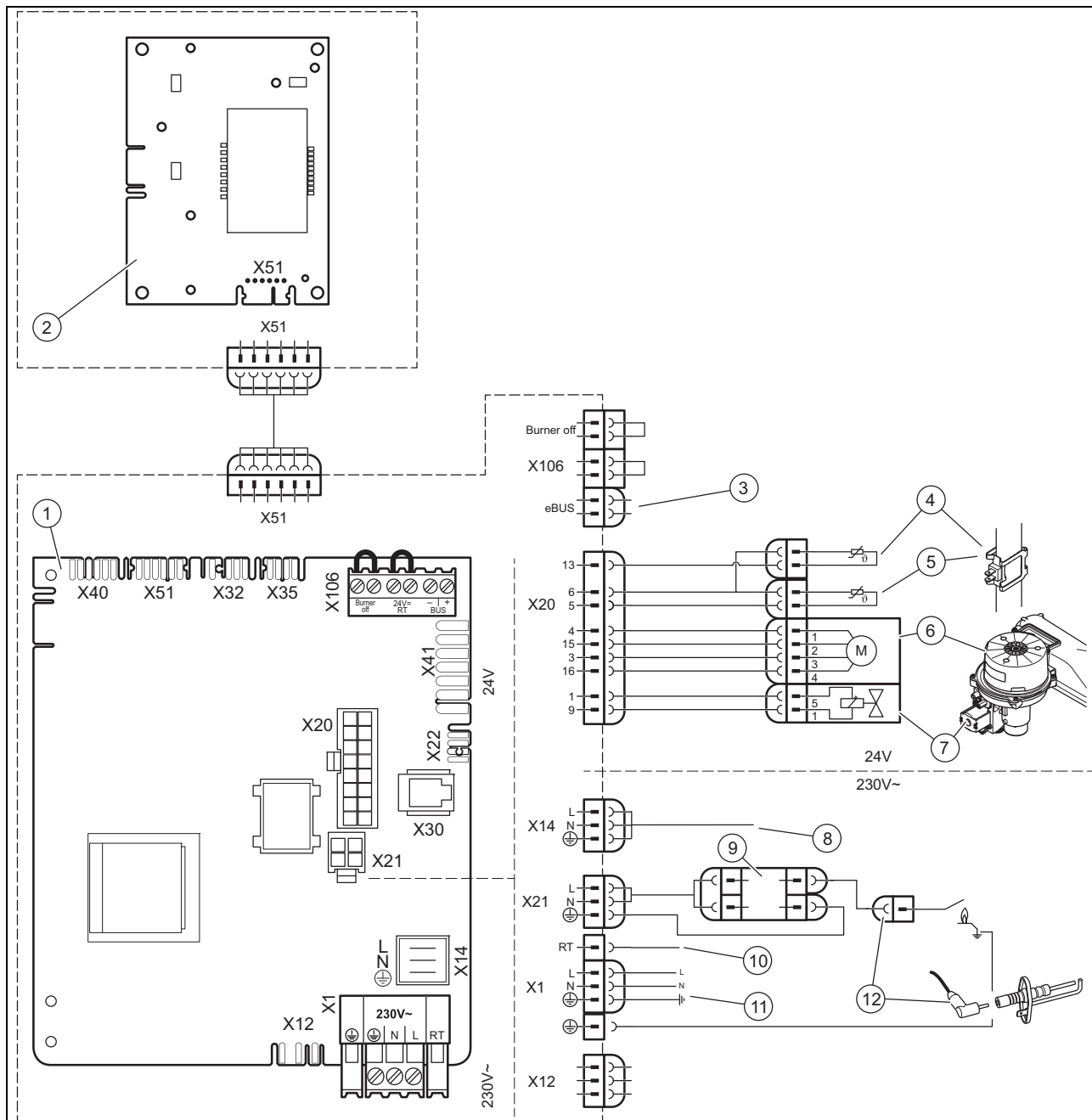

- |   |  |    |  |
|---|--|----|--|
| 1 | Main PCB                                 | 7  | Gas valve assembly                                 |
| 2 | Interface PCB                            | 8  | Heating pump                                       |
| 3 | Control system                           | 9  | Monitoring electrode                               |
| 4 | Temperature sensor on the heating flow   | 10 | Room thermostat                                    |
| 5 | Temperature sensor on the heating return | 11 | Main power supply and connection for 230 V control |
| 6 | Fan                                      | 12 | Ignition electrode                                 |

## Appendix

### G Position of the opening in the air/flue pipe

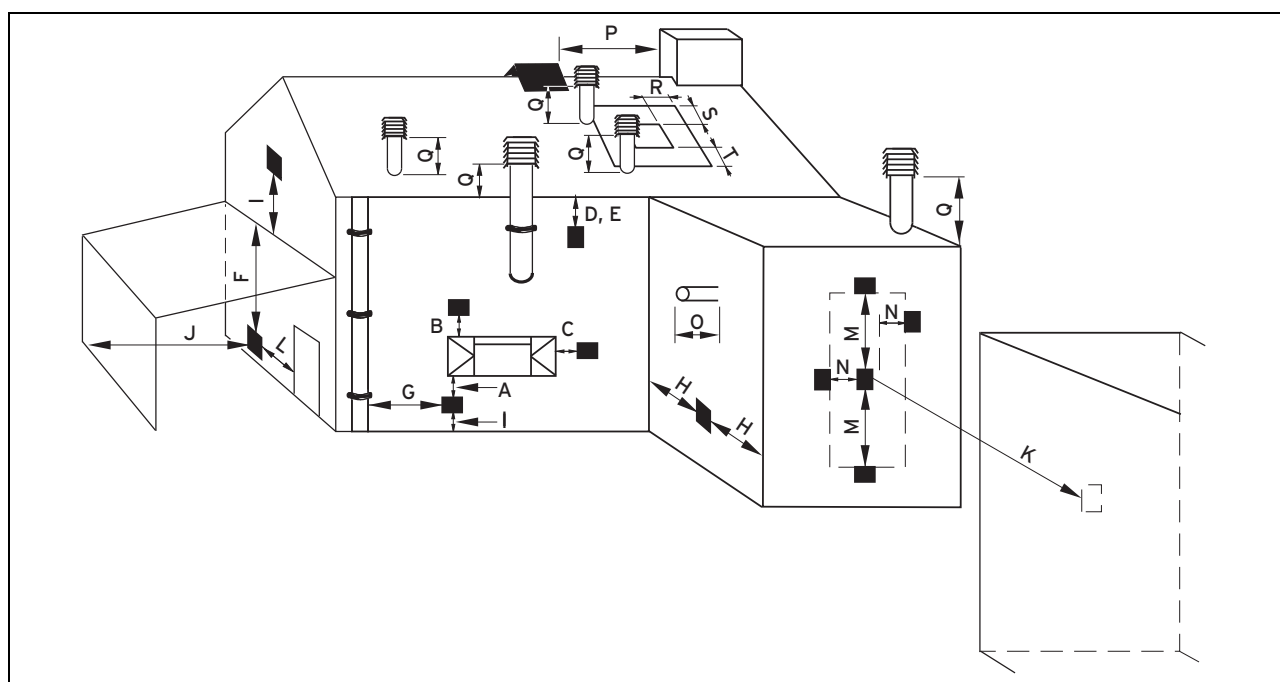

#### G.1 Positioning of the opening of a fan-supported flue gas pipe

|   | Installation site   | Minimum dimensions |
|---|---|--------------------|
| A | Directly below an opening, air bricks, opening windows, etc., that can be opened.                     | 300 mm             |
| B | Above an opening, air bricks, opening windows, etc., that can be opened.                              | 300 mm             |
| C | Horizontally to an opening, air bricks, opening windows, etc., that can be opened.                    | 300 mm             |
| D | Below temperature-sensitive building components, e.g. plastic gutters, down pipes or wastewater pipes | 75 mm              |
| E | Below eaves   | 200 mm             |
| F | Below balconies or car port roofs   | 200 mm             |
| G | From vertical wastewater pipes or down pipes  | 150 mm             |
| H | From external or internal corners   | 200 mm             |
| I | Above floors, roofs or balconies  | 300 mm             |
| J | From a surface facing a terminal  | 600 mm             |
| K | From a terminal facing a terminal   | 1,200 mm           |
| L | From an opening in the car port (e.g. door, window) which leads into the dwelling                     | 1,200 mm           |
| M | Vertical from a terminal on the same wall   | 1,500 mm           |
| N | Horizontal from a terminal on the same wall   | 300 mm             |
| O | From the wall on which the terminal has been installed  | 0 mm               |
| P | From a vertical structure on the roof   | 300 mm             |
| Q | Above the roof area   | 300 mm             |
| R | Horizontal from adjacent windows on pitched or flat roofs   | 600 mm             |
| S | Above adjacent windows on pitched or flat roofs   | 600 mm             |
| T | Below adjacent windows on pitched or flat roofs   | 2,000 mm           |

**G.2 Horizontal terminal positioning**

BS 5440-1 recommends that fanned flue chimney terminals should be positioned as follows:

- a) at least 2 m from an opening in the building directly opposite, and
- b) so that the products of combustion are not directed to discharge directly across a boundary if the products are likely to cause a nuisance to a neighbour or discharge over a walkway or patio.

For IE see current issue of IS 813.

For boilers covered within this manual.

1) Dimensions D, E, F and G:

These clearances may be reduced to 25 mm without affecting the performance of the boiler. In order to ensure that the condensate plume does not affect adjacent surfaces the terminal should be extended as shown below.

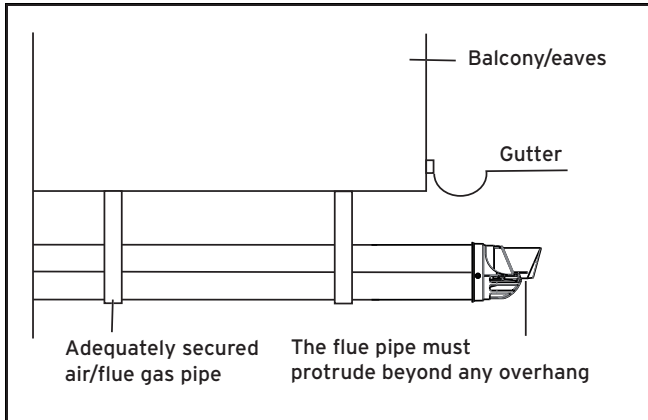

2) Dimension H:

This clearance may be reduced to 25 mm without affecting the performance of the boiler. However, in order to ensure that the condensate plume does not affect adjacent surfaces a clearance of 300 mm is preferred.

For 1 and 2 above you can use a flue gas management kit to enable the termination point to be positioned and directed away from the building fabric.

### H Commissioning Checklist

## Benchmark Commissioning and Servicing Section

It is a requirement that the boiler is installed and commissioned to the manufacturers instructions and the data fields on the commissioning checklist completed in full.

To instigate the boiler guarantee the boiler needs to be registered with the manufacturer within one month of the installation.

To maintain the boiler guarantee it is essential that the boiler is serviced annually by a Gas Safe registered engineer who has been trained on the boiler installed. The service details should be recorded on the Benchmark Service Interval Record and left with the householder.



[www.centralheating.co.uk](http://www.centralheating.co.uk)

**GAS BOILER SYSTEM COMMISSIONING CHECKLIST**

This Commissioning Checklist is to be completed in full by the competent person who commissioned the boiler as a means of demonstrating compliance with the appropriate Building Regulations and then handed to the customer to keep for future reference.

Failure to install and commission according to the manufacturer's instructions and complete this Benchmark Commissioning Checklist will invalidate the warranty. This does not affect the customer's statutory rights.

|                               |                           |
|-------------------------------|---------------------------|
| Customer name:                | Telephone number:         |
| Address:                      |                           |
| Boiler make and model:        |                           |
| Boiler serial number:         |                           |
| Commissioned by (PRINT NAME): | Gas Safe register number: |
| Company name:                 | Telephone number:         |
| Company address:              |                           |
| Commissioning date:           |                           |

**To be completed by the customer on receipt of a Building Regulations Compliance Certificate\***

Building Regulations Notification Number (if applicable):

| CONTROLS (tick the appropriate boxes)     |  |  |                              |
|---|--|--|------------------------------|
| Time and temperature control to heating   | Room thermostat and programmer/timer     |  | Programmable room thermostat |
|   | Load/weather compensation                |  | Optimum start control        |
| Time and temperature control to hot water | Cylinder thermostat and programmer/timer |  | Combination Boiler           |
| Heating zone valves                       | Fitted                                   |  | Not required                 |
| Hot water zone valves                     | Fitted                                   |  | Not required                 |
| Thermostatic radiator valves              | Fitted                                   |  | Not required                 |
| Automatic bypass to system                | Fitted                                   |  | Not required                 |
| Boiler interlock                          |  |  | Provided                     |

| ALL SYSTEMS  |          |        |  |
|--|----------|--------|--|
| The system has been flushed and cleaned in accordance with BS7593 and boiler manufacturer's instructions | Yes      |        |  |
| What system cleaner was used?  |          |        |  |
| What inhibitor was used?   | Quantity | litres |  |
| Has a primary water system filter been installed?  | Yes      | No     |  |

| CENTRAL HEATING MODE measure and record:  |                    |                       |                     |
|---|--------------------|-----------------------|---------------------|
| Gas rate                                  | m <sup>3</sup> /hr | OR                    | ft <sup>3</sup> /hr |
| Burner operating pressure (if applicable) | mbar               | OR Gas inlet pressure | mbar                |
| Central heating flow temperature          |                    |                       | °C                  |
| Central heating return temperature        |                    |                       | °C                  |

| COMBINATION BOILERS ONLY  |     |    |  |
|---|-----|----|--|
| Is the installation in a hard water area (above 200ppm)?                            | Yes | No |  |
| If yes, and if required by the manufacturer, has a water scale reducer been fitted? | Yes | No |  |
| What type of scale reducer has been fitted?   |     |    |  |

| DOMESTIC HOT WATER MODE Measure and Record: |                    |                                       |                     |
|---|--------------------|---------------------------------------|---------------------|
| Gas rate                                    | m <sup>3</sup> /hr | OR                                    | ft <sup>3</sup> /hr |
| Burner operating pressure (at maximum rate) | mbar               | OR Gas inlet pressure at maximum rate | mbar                |
| Cold water inlet temperature                |                    |                                       | °C                  |
| Hot water has been checked at all outlets   | Yes                | Temperature                           | °C                  |
| Water flow rate                             |                    |                                       | l/min               |

| CONDENSING BOILERS ONLY   |     |
|---|-----|
| The condensate drain has been installed in accordance with the manufacturer's instructions and/or BS5546/BS6798 | Yes |

| ALL INSTALLATIONS  |                                |    |     |     |                          |
|--|--------------------------------|----|-----|-----|--------------------------|
| Record the following:  | At max. rate:                  | CO | ppm | AND | CO/CO <sub>2</sub> Ratio |
|  | At min. rate: (where possible) | CO | ppm | AND | CO/CO <sub>2</sub> Ratio |
| The heating and hot water system complies with the appropriate Building Regulations  |                                |    |     |     | Yes                      |
| The boiler and associated products have been installed and commissioned in accordance with the manufacturer's instructions     |                                |    |     |     | Yes                      |
| The operation of the boiler and system controls have been demonstrated to and understood by the customer                       |                                |    |     |     | Yes                      |
| The manufacturer's literature, including Benchmark Checklist and Service Record, has been explained and left with the customer |                                |    |     |     | Yes                      |

|  |
|--|
| Commissioning Engineer's Signature   |
| Customer's Signature   |
| (To confirm satisfactory demonstration and receipt of manufacturer's literature) |

\*All installations in England and Wales must be notified to Local Authority Building Control (LABC) either directly or through a Competent Persons Scheme. A Building Regulations Compliance Certificate will then be issued to the customer.



# Appendix

## SERVICE RECORD

It is recommended that your heating system is serviced regularly and that the appropriate Service Interval Record is completed.

### Service Provider

Before completing the appropriate Service Record below, please ensure you have carried out the service as described in the manufacturer's instructions. Always use the manufacturer's specified spare part when replacing controls.

|   |                                |        |                       |  |                |  |  |  |               |  |  |  |               |  |  |  |                       |  |  |  |         |               |        |                       |  |                                |        |                       |           |  |  |  |           |  |  |  |   |                   |  |       |  |                |  |  |  |               |  |  |  |               |  |  |  |                       |  |  |  |         |               |        |                       |  |                                |        |                       |           |  |  |  |           |  |  |  |
|---|--------------------------------|--------|-----------------------|--|----------------|--|--|--|---------------|--|--|--|---------------|--|--|--|-----------------------|--|--|--|---------|---------------|--------|-----------------------|--|--------------------------------|--------|-----------------------|-----------|--|--|--|-----------|--|--|--|---|-------------------|--|-------|--|----------------|--|--|--|---------------|--|--|--|---------------|--|--|--|-----------------------|--|--|--|---------|---------------|--------|-----------------------|--|--------------------------------|--------|-----------------------|-----------|--|--|--|-----------|--|--|--|
| <table border="1" style="width: 100%; border-collapse: collapse;"> <tr> <td colspan="2"><b>SERVICE 01</b></td> <td colspan="2">Date:</td> </tr> <tr> <td colspan="4">Engineer name:</td> </tr> <tr> <td colspan="4">Company name:</td> </tr> <tr> <td colspan="4">Telephone No:</td> </tr> <tr> <td colspan="4">Gas safe register No:</td> </tr> <tr> <td>Record:</td> <td>At max. rate:</td> <td>CO ppm</td> <td>AND CO<sub>2</sub> %</td> </tr> <tr> <td></td> <td>At min. rate: (Where Possible)</td> <td>CO ppm</td> <td>AND CO<sub>2</sub> %</td> </tr> <tr> <td colspan="4">Comments:</td> </tr> <tr> <td colspan="4">Signature</td> </tr> </table> | <b>SERVICE 01</b>              |        | Date:                 |  | Engineer name: |  |  |  | Company name: |  |  |  | Telephone No: |  |  |  | Gas safe register No: |  |  |  | Record: | At max. rate: | CO ppm | AND CO <sub>2</sub> % |  | At min. rate: (Where Possible) | CO ppm | AND CO <sub>2</sub> % | Comments: |  |  |  | Signature |  |  |  | <table border="1" style="width: 100%; border-collapse: collapse;"> <tr> <td colspan="2"><b>SERVICE 02</b></td> <td colspan="2">Date:</td> </tr> <tr> <td colspan="4">Engineer name:</td> </tr> <tr> <td colspan="4">Company name:</td> </tr> <tr> <td colspan="4">Telephone No:</td> </tr> <tr> <td colspan="4">Gas safe register No:</td> </tr> <tr> <td>Record:</td> <td>At max. rate:</td> <td>CO ppm</td> <td>AND CO<sub>2</sub> %</td> </tr> <tr> <td></td> <td>At min. rate: (Where Possible)</td> <td>CO ppm</td> <td>AND CO<sub>2</sub> %</td> </tr> <tr> <td colspan="4">Comments:</td> </tr> <tr> <td colspan="4">Signature</td> </tr> </table> | <b>SERVICE 02</b> |  | Date: |  | Engineer name: |  |  |  | Company name: |  |  |  | Telephone No: |  |  |  | Gas safe register No: |  |  |  | Record: | At max. rate: | CO ppm | AND CO <sub>2</sub> % |  | At min. rate: (Where Possible) | CO ppm | AND CO <sub>2</sub> % | Comments: |  |  |  | Signature |  |  |  |
| <b>SERVICE 01</b>   |                                | Date:  |                       |  |                |  |  |  |               |  |  |  |               |  |  |  |                       |  |  |  |         |               |        |                       |  |                                |        |                       |           |  |  |  |           |  |  |  |   |                   |  |       |  |                |  |  |  |               |  |  |  |               |  |  |  |                       |  |  |  |         |               |        |                       |  |                                |        |                       |           |  |  |  |           |  |  |  |
| Engineer name:  |                                |        |                       |  |                |  |  |  |               |  |  |  |               |  |  |  |                       |  |  |  |         |               |        |                       |  |                                |        |                       |           |  |  |  |           |  |  |  |   |                   |  |       |  |                |  |  |  |               |  |  |  |               |  |  |  |                       |  |  |  |         |               |        |                       |  |                                |        |                       |           |  |  |  |           |  |  |  |
| Company name:   |                                |        |                       |  |                |  |  |  |               |  |  |  |               |  |  |  |                       |  |  |  |         |               |        |                       |  |                                |        |                       |           |  |  |  |           |  |  |  |   |                   |  |       |  |                |  |  |  |               |  |  |  |               |  |  |  |                       |  |  |  |         |               |        |                       |  |                                |        |                       |           |  |  |  |           |  |  |  |
| Telephone No:   |                                |        |                       |  |                |  |  |  |               |  |  |  |               |  |  |  |                       |  |  |  |         |               |        |                       |  |                                |        |                       |           |  |  |  |           |  |  |  |   |                   |  |       |  |                |  |  |  |               |  |  |  |               |  |  |  |                       |  |  |  |         |               |        |                       |  |                                |        |                       |           |  |  |  |           |  |  |  |
| Gas safe register No:   |                                |        |                       |  |                |  |  |  |               |  |  |  |               |  |  |  |                       |  |  |  |         |               |        |                       |  |                                |        |                       |           |  |  |  |           |  |  |  |   |                   |  |       |  |                |  |  |  |               |  |  |  |               |  |  |  |                       |  |  |  |         |               |        |                       |  |                                |        |                       |           |  |  |  |           |  |  |  |
| Record:   | At max. rate:                  | CO ppm | AND CO <sub>2</sub> % |  |                |  |  |  |               |  |  |  |               |  |  |  |                       |  |  |  |         |               |        |                       |  |                                |        |                       |           |  |  |  |           |  |  |  |   |                   |  |       |  |                |  |  |  |               |  |  |  |               |  |  |  |                       |  |  |  |         |               |        |                       |  |                                |        |                       |           |  |  |  |           |  |  |  |
|   | At min. rate: (Where Possible) | CO ppm | AND CO <sub>2</sub> % |  |                |  |  |  |               |  |  |  |               |  |  |  |                       |  |  |  |         |               |        |                       |  |                                |        |                       |           |  |  |  |           |  |  |  |   |                   |  |       |  |                |  |  |  |               |  |  |  |               |  |  |  |                       |  |  |  |         |               |        |                       |  |                                |        |                       |           |  |  |  |           |  |  |  |
| Comments:   |                                |        |                       |  |                |  |  |  |               |  |  |  |               |  |  |  |                       |  |  |  |         |               |        |                       |  |                                |        |                       |           |  |  |  |           |  |  |  |   |                   |  |       |  |                |  |  |  |               |  |  |  |               |  |  |  |                       |  |  |  |         |               |        |                       |  |                                |        |                       |           |  |  |  |           |  |  |  |
| Signature   |                                |        |                       |  |                |  |  |  |               |  |  |  |               |  |  |  |                       |  |  |  |         |               |        |                       |  |                                |        |                       |           |  |  |  |           |  |  |  |   |                   |  |       |  |                |  |  |  |               |  |  |  |               |  |  |  |                       |  |  |  |         |               |        |                       |  |                                |        |                       |           |  |  |  |           |  |  |  |
| <b>SERVICE 02</b>   |                                | Date:  |                       |  |                |  |  |  |               |  |  |  |               |  |  |  |                       |  |  |  |         |               |        |                       |  |                                |        |                       |           |  |  |  |           |  |  |  |   |                   |  |       |  |                |  |  |  |               |  |  |  |               |  |  |  |                       |  |  |  |         |               |        |                       |  |                                |        |                       |           |  |  |  |           |  |  |  |
| Engineer name:  |                                |        |                       |  |                |  |  |  |               |  |  |  |               |  |  |  |                       |  |  |  |         |               |        |                       |  |                                |        |                       |           |  |  |  |           |  |  |  |   |                   |  |       |  |                |  |  |  |               |  |  |  |               |  |  |  |                       |  |  |  |         |               |        |                       |  |                                |        |                       |           |  |  |  |           |  |  |  |
| Company name:   |                                |        |                       |  |                |  |  |  |               |  |  |  |               |  |  |  |                       |  |  |  |         |               |        |                       |  |                                |        |                       |           |  |  |  |           |  |  |  |   |                   |  |       |  |                |  |  |  |               |  |  |  |               |  |  |  |                       |  |  |  |         |               |        |                       |  |                                |        |                       |           |  |  |  |           |  |  |  |
| Telephone No:   |                                |        |                       |  |                |  |  |  |               |  |  |  |               |  |  |  |                       |  |  |  |         |               |        |                       |  |                                |        |                       |           |  |  |  |           |  |  |  |   |                   |  |       |  |                |  |  |  |               |  |  |  |               |  |  |  |                       |  |  |  |         |               |        |                       |  |                                |        |                       |           |  |  |  |           |  |  |  |
| Gas safe register No:   |                                |        |                       |  |                |  |  |  |               |  |  |  |               |  |  |  |                       |  |  |  |         |               |        |                       |  |                                |        |                       |           |  |  |  |           |  |  |  |   |                   |  |       |  |                |  |  |  |               |  |  |  |               |  |  |  |                       |  |  |  |         |               |        |                       |  |                                |        |                       |           |  |  |  |           |  |  |  |
| Record:   | At max. rate:                  | CO ppm | AND CO <sub>2</sub> % |  |                |  |  |  |               |  |  |  |               |  |  |  |                       |  |  |  |         |               |        |                       |  |                                |        |                       |           |  |  |  |           |  |  |  |   |                   |  |       |  |                |  |  |  |               |  |  |  |               |  |  |  |                       |  |  |  |         |               |        |                       |  |                                |        |                       |           |  |  |  |           |  |  |  |
|   | At min. rate: (Where Possible) | CO ppm | AND CO <sub>2</sub> % |  |                |  |  |  |               |  |  |  |               |  |  |  |                       |  |  |  |         |               |        |                       |  |                                |        |                       |           |  |  |  |           |  |  |  |   |                   |  |       |  |                |  |  |  |               |  |  |  |               |  |  |  |                       |  |  |  |         |               |        |                       |  |                                |        |                       |           |  |  |  |           |  |  |  |
| Comments:   |                                |        |                       |  |                |  |  |  |               |  |  |  |               |  |  |  |                       |  |  |  |         |               |        |                       |  |                                |        |                       |           |  |  |  |           |  |  |  |   |                   |  |       |  |                |  |  |  |               |  |  |  |               |  |  |  |                       |  |  |  |         |               |        |                       |  |                                |        |                       |           |  |  |  |           |  |  |  |
| Signature   |                                |        |                       |  |                |  |  |  |               |  |  |  |               |  |  |  |                       |  |  |  |         |               |        |                       |  |                                |        |                       |           |  |  |  |           |  |  |  |   |                   |  |       |  |                |  |  |  |               |  |  |  |               |  |  |  |                       |  |  |  |         |               |        |                       |  |                                |        |                       |           |  |  |  |           |  |  |  |
| <table border="1" style="width: 100%; border-collapse: collapse;"> <tr> <td colspan="2"><b>SERVICE 03</b></td> <td colspan="2">Date:</td> </tr> <tr> <td colspan="4">Engineer name:</td> </tr> <tr> <td colspan="4">Company name:</td> </tr> <tr> <td colspan="4">Telephone No:</td> </tr> <tr> <td colspan="4">Gas safe register No:</td> </tr> <tr> <td>Record:</td> <td>At max. rate:</td> <td>CO ppm</td> <td>AND CO<sub>2</sub> %</td> </tr> <tr> <td></td> <td>At min. rate: (Where Possible)</td> <td>CO ppm</td> <td>AND CO<sub>2</sub> %</td> </tr> <tr> <td colspan="4">Comments:</td> </tr> <tr> <td colspan="4">Signature</td> </tr> </table> | <b>SERVICE 03</b>              |        | Date:                 |  | Engineer name: |  |  |  | Company name: |  |  |  | Telephone No: |  |  |  | Gas safe register No: |  |  |  | Record: | At max. rate: | CO ppm | AND CO <sub>2</sub> % |  | At min. rate: (Where Possible) | CO ppm | AND CO <sub>2</sub> % | Comments: |  |  |  | Signature |  |  |  | <table border="1" style="width: 100%; border-collapse: collapse;"> <tr> <td colspan="2"><b>SERVICE 04</b></td> <td colspan="2">Date:</td> </tr> <tr> <td colspan="4">Engineer name:</td> </tr> <tr> <td colspan="4">Company name:</td> </tr> <tr> <td colspan="4">Telephone No:</td> </tr> <tr> <td colspan="4">Gas safe register No:</td> </tr> <tr> <td>Record:</td> <td>At max. rate:</td> <td>CO ppm</td> <td>AND CO<sub>2</sub> %</td> </tr> <tr> <td></td> <td>At min. rate: (Where Possible)</td> <td>CO ppm</td> <td>AND CO<sub>2</sub> %</td> </tr> <tr> <td colspan="4">Comments:</td> </tr> <tr> <td colspan="4">Signature</td> </tr> </table> | <b>SERVICE 04</b> |  | Date: |  | Engineer name: |  |  |  | Company name: |  |  |  | Telephone No: |  |  |  | Gas safe register No: |  |  |  | Record: | At max. rate: | CO ppm | AND CO <sub>2</sub> % |  | At min. rate: (Where Possible) | CO ppm | AND CO <sub>2</sub> % | Comments: |  |  |  | Signature |  |  |  |
| <b>SERVICE 03</b>   |                                | Date:  |                       |  |                |  |  |  |               |  |  |  |               |  |  |  |                       |  |  |  |         |               |        |                       |  |                                |        |                       |           |  |  |  |           |  |  |  |   |                   |  |       |  |                |  |  |  |               |  |  |  |               |  |  |  |                       |  |  |  |         |               |        |                       |  |                                |        |                       |           |  |  |  |           |  |  |  |
| Engineer name:  |                                |        |                       |  |                |  |  |  |               |  |  |  |               |  |  |  |                       |  |  |  |         |               |        |                       |  |                                |        |                       |           |  |  |  |           |  |  |  |   |                   |  |       |  |                |  |  |  |               |  |  |  |               |  |  |  |                       |  |  |  |         |               |        |                       |  |                                |        |                       |           |  |  |  |           |  |  |  |
| Company name:   |                                |        |                       |  |                |  |  |  |               |  |  |  |               |  |  |  |                       |  |  |  |         |               |        |                       |  |                                |        |                       |           |  |  |  |           |  |  |  |   |                   |  |       |  |                |  |  |  |               |  |  |  |               |  |  |  |                       |  |  |  |         |               |        |                       |  |                                |        |                       |           |  |  |  |           |  |  |  |
| Telephone No:   |                                |        |                       |  |                |  |  |  |               |  |  |  |               |  |  |  |                       |  |  |  |         |               |        |                       |  |                                |        |                       |           |  |  |  |           |  |  |  |   |                   |  |       |  |                |  |  |  |               |  |  |  |               |  |  |  |                       |  |  |  |         |               |        |                       |  |                                |        |                       |           |  |  |  |           |  |  |  |
| Gas safe register No:   |                                |        |                       |  |                |  |  |  |               |  |  |  |               |  |  |  |                       |  |  |  |         |               |        |                       |  |                                |        |                       |           |  |  |  |           |  |  |  |   |                   |  |       |  |                |  |  |  |               |  |  |  |               |  |  |  |                       |  |  |  |         |               |        |                       |  |                                |        |                       |           |  |  |  |           |  |  |  |
| Record:   | At max. rate:                  | CO ppm | AND CO <sub>2</sub> % |  |                |  |  |  |               |  |  |  |               |  |  |  |                       |  |  |  |         |               |        |                       |  |                                |        |                       |           |  |  |  |           |  |  |  |   |                   |  |       |  |                |  |  |  |               |  |  |  |               |  |  |  |                       |  |  |  |         |               |        |                       |  |                                |        |                       |           |  |  |  |           |  |  |  |
|   | At min. rate: (Where Possible) | CO ppm | AND CO <sub>2</sub> % |  |                |  |  |  |               |  |  |  |               |  |  |  |                       |  |  |  |         |               |        |                       |  |                                |        |                       |           |  |  |  |           |  |  |  |   |                   |  |       |  |                |  |  |  |               |  |  |  |               |  |  |  |                       |  |  |  |         |               |        |                       |  |                                |        |                       |           |  |  |  |           |  |  |  |
| Comments:   |                                |        |                       |  |                |  |  |  |               |  |  |  |               |  |  |  |                       |  |  |  |         |               |        |                       |  |                                |        |                       |           |  |  |  |           |  |  |  |   |                   |  |       |  |                |  |  |  |               |  |  |  |               |  |  |  |                       |  |  |  |         |               |        |                       |  |                                |        |                       |           |  |  |  |           |  |  |  |
| Signature   |                                |        |                       |  |                |  |  |  |               |  |  |  |               |  |  |  |                       |  |  |  |         |               |        |                       |  |                                |        |                       |           |  |  |  |           |  |  |  |   |                   |  |       |  |                |  |  |  |               |  |  |  |               |  |  |  |                       |  |  |  |         |               |        |                       |  |                                |        |                       |           |  |  |  |           |  |  |  |
| <b>SERVICE 04</b>   |                                | Date:  |                       |  |                |  |  |  |               |  |  |  |               |  |  |  |                       |  |  |  |         |               |        |                       |  |                                |        |                       |           |  |  |  |           |  |  |  |   |                   |  |       |  |                |  |  |  |               |  |  |  |               |  |  |  |                       |  |  |  |         |               |        |                       |  |                                |        |                       |           |  |  |  |           |  |  |  |
| Engineer name:  |                                |        |                       |  |                |  |  |  |               |  |  |  |               |  |  |  |                       |  |  |  |         |               |        |                       |  |                                |        |                       |           |  |  |  |           |  |  |  |   |                   |  |       |  |                |  |  |  |               |  |  |  |               |  |  |  |                       |  |  |  |         |               |        |                       |  |                                |        |                       |           |  |  |  |           |  |  |  |
| Company name:   |                                |        |                       |  |                |  |  |  |               |  |  |  |               |  |  |  |                       |  |  |  |         |               |        |                       |  |                                |        |                       |           |  |  |  |           |  |  |  |   |                   |  |       |  |                |  |  |  |               |  |  |  |               |  |  |  |                       |  |  |  |         |               |        |                       |  |                                |        |                       |           |  |  |  |           |  |  |  |
| Telephone No:   |                                |        |                       |  |                |  |  |  |               |  |  |  |               |  |  |  |                       |  |  |  |         |               |        |                       |  |                                |        |                       |           |  |  |  |           |  |  |  |   |                   |  |       |  |                |  |  |  |               |  |  |  |               |  |  |  |                       |  |  |  |         |               |        |                       |  |                                |        |                       |           |  |  |  |           |  |  |  |
| Gas safe register No:   |                                |        |                       |  |                |  |  |  |               |  |  |  |               |  |  |  |                       |  |  |  |         |               |        |                       |  |                                |        |                       |           |  |  |  |           |  |  |  |   |                   |  |       |  |                |  |  |  |               |  |  |  |               |  |  |  |                       |  |  |  |         |               |        |                       |  |                                |        |                       |           |  |  |  |           |  |  |  |
| Record:   | At max. rate:                  | CO ppm | AND CO <sub>2</sub> % |  |                |  |  |  |               |  |  |  |               |  |  |  |                       |  |  |  |         |               |        |                       |  |                                |        |                       |           |  |  |  |           |  |  |  |   |                   |  |       |  |                |  |  |  |               |  |  |  |               |  |  |  |                       |  |  |  |         |               |        |                       |  |                                |        |                       |           |  |  |  |           |  |  |  |
|   | At min. rate: (Where Possible) | CO ppm | AND CO <sub>2</sub> % |  |                |  |  |  |               |  |  |  |               |  |  |  |                       |  |  |  |         |               |        |                       |  |                                |        |                       |           |  |  |  |           |  |  |  |   |                   |  |       |  |                |  |  |  |               |  |  |  |               |  |  |  |                       |  |  |  |         |               |        |                       |  |                                |        |                       |           |  |  |  |           |  |  |  |
| Comments:   |                                |        |                       |  |                |  |  |  |               |  |  |  |               |  |  |  |                       |  |  |  |         |               |        |                       |  |                                |        |                       |           |  |  |  |           |  |  |  |   |                   |  |       |  |                |  |  |  |               |  |  |  |               |  |  |  |                       |  |  |  |         |               |        |                       |  |                                |        |                       |           |  |  |  |           |  |  |  |
| Signature   |                                |        |                       |  |                |  |  |  |               |  |  |  |               |  |  |  |                       |  |  |  |         |               |        |                       |  |                                |        |                       |           |  |  |  |           |  |  |  |   |                   |  |       |  |                |  |  |  |               |  |  |  |               |  |  |  |                       |  |  |  |         |               |        |                       |  |                                |        |                       |           |  |  |  |           |  |  |  |
| <table border="1" style="width: 100%; border-collapse: collapse;"> <tr> <td colspan="2"><b>SERVICE 05</b></td> <td colspan="2">Date:</td> </tr> <tr> <td colspan="4">Engineer name:</td> </tr> <tr> <td colspan="4">Company name:</td> </tr> <tr> <td colspan="4">Telephone No:</td> </tr> <tr> <td colspan="4">Gas safe register No:</td> </tr> <tr> <td>Record:</td> <td>At max. rate:</td> <td>CO ppm</td> <td>AND CO<sub>2</sub> %</td> </tr> <tr> <td></td> <td>At min. rate: (Where Possible)</td> <td>CO ppm</td> <td>AND CO<sub>2</sub> %</td> </tr> <tr> <td colspan="4">Comments:</td> </tr> <tr> <td colspan="4">Signature</td> </tr> </table> | <b>SERVICE 05</b>              |        | Date:                 |  | Engineer name: |  |  |  | Company name: |  |  |  | Telephone No: |  |  |  | Gas safe register No: |  |  |  | Record: | At max. rate: | CO ppm | AND CO <sub>2</sub> % |  | At min. rate: (Where Possible) | CO ppm | AND CO <sub>2</sub> % | Comments: |  |  |  | Signature |  |  |  | <table border="1" style="width: 100%; border-collapse: collapse;"> <tr> <td colspan="2"><b>SERVICE 06</b></td> <td colspan="2">Date:</td> </tr> <tr> <td colspan="4">Engineer name:</td> </tr> <tr> <td colspan="4">Company name:</td> </tr> <tr> <td colspan="4">Telephone No:</td> </tr> <tr> <td colspan="4">Gas safe register No:</td> </tr> <tr> <td>Record:</td> <td>At max. rate:</td> <td>CO ppm</td> <td>AND CO<sub>2</sub> %</td> </tr> <tr> <td></td> <td>At min. rate: (Where Possible)</td> <td>CO ppm</td> <td>AND CO<sub>2</sub> %</td> </tr> <tr> <td colspan="4">Comments:</td> </tr> <tr> <td colspan="4">Signature</td> </tr> </table> | <b>SERVICE 06</b> |  | Date: |  | Engineer name: |  |  |  | Company name: |  |  |  | Telephone No: |  |  |  | Gas safe register No: |  |  |  | Record: | At max. rate: | CO ppm | AND CO <sub>2</sub> % |  | At min. rate: (Where Possible) | CO ppm | AND CO <sub>2</sub> % | Comments: |  |  |  | Signature |  |  |  |
| <b>SERVICE 05</b>   |                                | Date:  |                       |  |                |  |  |  |               |  |  |  |               |  |  |  |                       |  |  |  |         |               |        |                       |  |                                |        |                       |           |  |  |  |           |  |  |  |   |                   |  |       |  |                |  |  |  |               |  |  |  |               |  |  |  |                       |  |  |  |         |               |        |                       |  |                                |        |                       |           |  |  |  |           |  |  |  |
| Engineer name:  |                                |        |                       |  |                |  |  |  |               |  |  |  |               |  |  |  |                       |  |  |  |         |               |        |                       |  |                                |        |                       |           |  |  |  |           |  |  |  |   |                   |  |       |  |                |  |  |  |               |  |  |  |               |  |  |  |                       |  |  |  |         |               |        |                       |  |                                |        |                       |           |  |  |  |           |  |  |  |
| Company name:   |                                |        |                       |  |                |  |  |  |               |  |  |  |               |  |  |  |                       |  |  |  |         |               |        |                       |  |                                |        |                       |           |  |  |  |           |  |  |  |   |                   |  |       |  |                |  |  |  |               |  |  |  |               |  |  |  |                       |  |  |  |         |               |        |                       |  |                                |        |                       |           |  |  |  |           |  |  |  |
| Telephone No:   |                                |        |                       |  |                |  |  |  |               |  |  |  |               |  |  |  |                       |  |  |  |         |               |        |                       |  |                                |        |                       |           |  |  |  |           |  |  |  |   |                   |  |       |  |                |  |  |  |               |  |  |  |               |  |  |  |                       |  |  |  |         |               |        |                       |  |                                |        |                       |           |  |  |  |           |  |  |  |
| Gas safe register No:   |                                |        |                       |  |                |  |  |  |               |  |  |  |               |  |  |  |                       |  |  |  |         |               |        |                       |  |                                |        |                       |           |  |  |  |           |  |  |  |   |                   |  |       |  |                |  |  |  |               |  |  |  |               |  |  |  |                       |  |  |  |         |               |        |                       |  |                                |        |                       |           |  |  |  |           |  |  |  |
| Record:   | At max. rate:                  | CO ppm | AND CO <sub>2</sub> % |  |                |  |  |  |               |  |  |  |               |  |  |  |                       |  |  |  |         |               |        |                       |  |                                |        |                       |           |  |  |  |           |  |  |  |   |                   |  |       |  |                |  |  |  |               |  |  |  |               |  |  |  |                       |  |  |  |         |               |        |                       |  |                                |        |                       |           |  |  |  |           |  |  |  |
|   | At min. rate: (Where Possible) | CO ppm | AND CO <sub>2</sub> % |  |                |  |  |  |               |  |  |  |               |  |  |  |                       |  |  |  |         |               |        |                       |  |                                |        |                       |           |  |  |  |           |  |  |  |   |                   |  |       |  |                |  |  |  |               |  |  |  |               |  |  |  |                       |  |  |  |         |               |        |                       |  |                                |        |                       |           |  |  |  |           |  |  |  |
| Comments:   |                                |        |                       |  |                |  |  |  |               |  |  |  |               |  |  |  |                       |  |  |  |         |               |        |                       |  |                                |        |                       |           |  |  |  |           |  |  |  |   |                   |  |       |  |                |  |  |  |               |  |  |  |               |  |  |  |                       |  |  |  |         |               |        |                       |  |                                |        |                       |           |  |  |  |           |  |  |  |
| Signature   |                                |        |                       |  |                |  |  |  |               |  |  |  |               |  |  |  |                       |  |  |  |         |               |        |                       |  |                                |        |                       |           |  |  |  |           |  |  |  |   |                   |  |       |  |                |  |  |  |               |  |  |  |               |  |  |  |                       |  |  |  |         |               |        |                       |  |                                |        |                       |           |  |  |  |           |  |  |  |
| <b>SERVICE 06</b>   |                                | Date:  |                       |  |                |  |  |  |               |  |  |  |               |  |  |  |                       |  |  |  |         |               |        |                       |  |                                |        |                       |           |  |  |  |           |  |  |  |   |                   |  |       |  |                |  |  |  |               |  |  |  |               |  |  |  |                       |  |  |  |         |               |        |                       |  |                                |        |                       |           |  |  |  |           |  |  |  |
| Engineer name:  |                                |        |                       |  |                |  |  |  |               |  |  |  |               |  |  |  |                       |  |  |  |         |               |        |                       |  |                                |        |                       |           |  |  |  |           |  |  |  |   |                   |  |       |  |                |  |  |  |               |  |  |  |               |  |  |  |                       |  |  |  |         |               |        |                       |  |                                |        |                       |           |  |  |  |           |  |  |  |
| Company name:   |                                |        |                       |  |                |  |  |  |               |  |  |  |               |  |  |  |                       |  |  |  |         |               |        |                       |  |                                |        |                       |           |  |  |  |           |  |  |  |   |                   |  |       |  |                |  |  |  |               |  |  |  |               |  |  |  |                       |  |  |  |         |               |        |                       |  |                                |        |                       |           |  |  |  |           |  |  |  |
| Telephone No:   |                                |        |                       |  |                |  |  |  |               |  |  |  |               |  |  |  |                       |  |  |  |         |               |        |                       |  |                                |        |                       |           |  |  |  |           |  |  |  |   |                   |  |       |  |                |  |  |  |               |  |  |  |               |  |  |  |                       |  |  |  |         |               |        |                       |  |                                |        |                       |           |  |  |  |           |  |  |  |
| Gas safe register No:   |                                |        |                       |  |                |  |  |  |               |  |  |  |               |  |  |  |                       |  |  |  |         |               |        |                       |  |                                |        |                       |           |  |  |  |           |  |  |  |   |                   |  |       |  |                |  |  |  |               |  |  |  |               |  |  |  |                       |  |  |  |         |               |        |                       |  |                                |        |                       |           |  |  |  |           |  |  |  |
| Record:   | At max. rate:                  | CO ppm | AND CO <sub>2</sub> % |  |                |  |  |  |               |  |  |  |               |  |  |  |                       |  |  |  |         |               |        |                       |  |                                |        |                       |           |  |  |  |           |  |  |  |   |                   |  |       |  |                |  |  |  |               |  |  |  |               |  |  |  |                       |  |  |  |         |               |        |                       |  |                                |        |                       |           |  |  |  |           |  |  |  |
|   | At min. rate: (Where Possible) | CO ppm | AND CO <sub>2</sub> % |  |                |  |  |  |               |  |  |  |               |  |  |  |                       |  |  |  |         |               |        |                       |  |                                |        |                       |           |  |  |  |           |  |  |  |   |                   |  |       |  |                |  |  |  |               |  |  |  |               |  |  |  |                       |  |  |  |         |               |        |                       |  |                                |        |                       |           |  |  |  |           |  |  |  |
| Comments:   |                                |        |                       |  |                |  |  |  |               |  |  |  |               |  |  |  |                       |  |  |  |         |               |        |                       |  |                                |        |                       |           |  |  |  |           |  |  |  |   |                   |  |       |  |                |  |  |  |               |  |  |  |               |  |  |  |                       |  |  |  |         |               |        |                       |  |                                |        |                       |           |  |  |  |           |  |  |  |
| Signature   |                                |        |                       |  |                |  |  |  |               |  |  |  |               |  |  |  |                       |  |  |  |         |               |        |                       |  |                                |        |                       |           |  |  |  |           |  |  |  |   |                   |  |       |  |                |  |  |  |               |  |  |  |               |  |  |  |                       |  |  |  |         |               |        |                       |  |                                |        |                       |           |  |  |  |           |  |  |  |
| <table border="1" style="width: 100%; border-collapse: collapse;"> <tr> <td colspan="2"><b>SERVICE 07</b></td> <td colspan="2">Date:</td> </tr> <tr> <td colspan="4">Engineer name:</td> </tr> <tr> <td colspan="4">Company name:</td> </tr> <tr> <td colspan="4">Telephone No:</td> </tr> <tr> <td colspan="4">Gas safe register No:</td> </tr> <tr> <td>Record:</td> <td>At max. rate:</td> <td>CO ppm</td> <td>AND CO<sub>2</sub> %</td> </tr> <tr> <td></td> <td>At min. rate: (Where Possible)</td> <td>CO ppm</td> <td>AND CO<sub>2</sub> %</td> </tr> <tr> <td colspan="4">Comments:</td> </tr> <tr> <td colspan="4">Signature</td> </tr> </table> | <b>SERVICE 07</b>              |        | Date:                 |  | Engineer name: |  |  |  | Company name: |  |  |  | Telephone No: |  |  |  | Gas safe register No: |  |  |  | Record: | At max. rate: | CO ppm | AND CO <sub>2</sub> % |  | At min. rate: (Where Possible) | CO ppm | AND CO <sub>2</sub> % | Comments: |  |  |  | Signature |  |  |  | <table border="1" style="width: 100%; border-collapse: collapse;"> <tr> <td colspan="2"><b>SERVICE 08</b></td> <td colspan="2">Date:</td> </tr> <tr> <td colspan="4">Engineer name:</td> </tr> <tr> <td colspan="4">Company name:</td> </tr> <tr> <td colspan="4">Telephone No:</td> </tr> <tr> <td colspan="4">Gas safe register No:</td> </tr> <tr> <td>Record:</td> <td>At max. rate:</td> <td>CO ppm</td> <td>AND CO<sub>2</sub> %</td> </tr> <tr> <td></td> <td>At min. rate: (Where Possible)</td> <td>CO ppm</td> <td>AND CO<sub>2</sub> %</td> </tr> <tr> <td colspan="4">Comments:</td> </tr> <tr> <td colspan="4">Signature</td> </tr> </table> | <b>SERVICE 08</b> |  | Date: |  | Engineer name: |  |  |  | Company name: |  |  |  | Telephone No: |  |  |  | Gas safe register No: |  |  |  | Record: | At max. rate: | CO ppm | AND CO <sub>2</sub> % |  | At min. rate: (Where Possible) | CO ppm | AND CO <sub>2</sub> % | Comments: |  |  |  | Signature |  |  |  |
| <b>SERVICE 07</b>   |                                | Date:  |                       |  |                |  |  |  |               |  |  |  |               |  |  |  |                       |  |  |  |         |               |        |                       |  |                                |        |                       |           |  |  |  |           |  |  |  |   |                   |  |       |  |                |  |  |  |               |  |  |  |               |  |  |  |                       |  |  |  |         |               |        |                       |  |                                |        |                       |           |  |  |  |           |  |  |  |
| Engineer name:  |                                |        |                       |  |                |  |  |  |               |  |  |  |               |  |  |  |                       |  |  |  |         |               |        |                       |  |                                |        |                       |           |  |  |  |           |  |  |  |   |                   |  |       |  |                |  |  |  |               |  |  |  |               |  |  |  |                       |  |  |  |         |               |        |                       |  |                                |        |                       |           |  |  |  |           |  |  |  |
| Company name:   |                                |        |                       |  |                |  |  |  |               |  |  |  |               |  |  |  |                       |  |  |  |         |               |        |                       |  |                                |        |                       |           |  |  |  |           |  |  |  |   |                   |  |       |  |                |  |  |  |               |  |  |  |               |  |  |  |                       |  |  |  |         |               |        |                       |  |                                |        |                       |           |  |  |  |           |  |  |  |
| Telephone No:   |                                |        |                       |  |                |  |  |  |               |  |  |  |               |  |  |  |                       |  |  |  |         |               |        |                       |  |                                |        |                       |           |  |  |  |           |  |  |  |   |                   |  |       |  |                |  |  |  |               |  |  |  |               |  |  |  |                       |  |  |  |         |               |        |                       |  |                                |        |                       |           |  |  |  |           |  |  |  |
| Gas safe register No:   |                                |        |                       |  |                |  |  |  |               |  |  |  |               |  |  |  |                       |  |  |  |         |               |        |                       |  |                                |        |                       |           |  |  |  |           |  |  |  |   |                   |  |       |  |                |  |  |  |               |  |  |  |               |  |  |  |                       |  |  |  |         |               |        |                       |  |                                |        |                       |           |  |  |  |           |  |  |  |
| Record:   | At max. rate:                  | CO ppm | AND CO <sub>2</sub> % |  |                |  |  |  |               |  |  |  |               |  |  |  |                       |  |  |  |         |               |        |                       |  |                                |        |                       |           |  |  |  |           |  |  |  |   |                   |  |       |  |                |  |  |  |               |  |  |  |               |  |  |  |                       |  |  |  |         |               |        |                       |  |                                |        |                       |           |  |  |  |           |  |  |  |
|   | At min. rate: (Where Possible) | CO ppm | AND CO <sub>2</sub> % |  |                |  |  |  |               |  |  |  |               |  |  |  |                       |  |  |  |         |               |        |                       |  |                                |        |                       |           |  |  |  |           |  |  |  |   |                   |  |       |  |                |  |  |  |               |  |  |  |               |  |  |  |                       |  |  |  |         |               |        |                       |  |                                |        |                       |           |  |  |  |           |  |  |  |
| Comments:   |                                |        |                       |  |                |  |  |  |               |  |  |  |               |  |  |  |                       |  |  |  |         |               |        |                       |  |                                |        |                       |           |  |  |  |           |  |  |  |   |                   |  |       |  |                |  |  |  |               |  |  |  |               |  |  |  |                       |  |  |  |         |               |        |                       |  |                                |        |                       |           |  |  |  |           |  |  |  |
| Signature   |                                |        |                       |  |                |  |  |  |               |  |  |  |               |  |  |  |                       |  |  |  |         |               |        |                       |  |                                |        |                       |           |  |  |  |           |  |  |  |   |                   |  |       |  |                |  |  |  |               |  |  |  |               |  |  |  |                       |  |  |  |         |               |        |                       |  |                                |        |                       |           |  |  |  |           |  |  |  |
| <b>SERVICE 08</b>   |                                | Date:  |                       |  |                |  |  |  |               |  |  |  |               |  |  |  |                       |  |  |  |         |               |        |                       |  |                                |        |                       |           |  |  |  |           |  |  |  |   |                   |  |       |  |                |  |  |  |               |  |  |  |               |  |  |  |                       |  |  |  |         |               |        |                       |  |                                |        |                       |           |  |  |  |           |  |  |  |
| Engineer name:  |                                |        |                       |  |                |  |  |  |               |  |  |  |               |  |  |  |                       |  |  |  |         |               |        |                       |  |                                |        |                       |           |  |  |  |           |  |  |  |   |                   |  |       |  |                |  |  |  |               |  |  |  |               |  |  |  |                       |  |  |  |         |               |        |                       |  |                                |        |                       |           |  |  |  |           |  |  |  |
| Company name:   |                                |        |                       |  |                |  |  |  |               |  |  |  |               |  |  |  |                       |  |  |  |         |               |        |                       |  |                                |        |                       |           |  |  |  |           |  |  |  |   |                   |  |       |  |                |  |  |  |               |  |  |  |               |  |  |  |                       |  |  |  |         |               |        |                       |  |                                |        |                       |           |  |  |  |           |  |  |  |
| Telephone No:   |                                |        |                       |  |                |  |  |  |               |  |  |  |               |  |  |  |                       |  |  |  |         |               |        |                       |  |                                |        |                       |           |  |  |  |           |  |  |  |   |                   |  |       |  |                |  |  |  |               |  |  |  |               |  |  |  |                       |  |  |  |         |               |        |                       |  |                                |        |                       |           |  |  |  |           |  |  |  |
| Gas safe register No:   |                                |        |                       |  |                |  |  |  |               |  |  |  |               |  |  |  |                       |  |  |  |         |               |        |                       |  |                                |        |                       |           |  |  |  |           |  |  |  |   |                   |  |       |  |                |  |  |  |               |  |  |  |               |  |  |  |                       |  |  |  |         |               |        |                       |  |                                |        |                       |           |  |  |  |           |  |  |  |
| Record:   | At max. rate:                  | CO ppm | AND CO <sub>2</sub> % |  |                |  |  |  |               |  |  |  |               |  |  |  |                       |  |  |  |         |               |        |                       |  |                                |        |                       |           |  |  |  |           |  |  |  |   |                   |  |       |  |                |  |  |  |               |  |  |  |               |  |  |  |                       |  |  |  |         |               |        |                       |  |                                |        |                       |           |  |  |  |           |  |  |  |
|   | At min. rate: (Where Possible) | CO ppm | AND CO <sub>2</sub> % |  |                |  |  |  |               |  |  |  |               |  |  |  |                       |  |  |  |         |               |        |                       |  |                                |        |                       |           |  |  |  |           |  |  |  |   |                   |  |       |  |                |  |  |  |               |  |  |  |               |  |  |  |                       |  |  |  |         |               |        |                       |  |                                |        |                       |           |  |  |  |           |  |  |  |
| Comments:   |                                |        |                       |  |                |  |  |  |               |  |  |  |               |  |  |  |                       |  |  |  |         |               |        |                       |  |                                |        |                       |           |  |  |  |           |  |  |  |   |                   |  |       |  |                |  |  |  |               |  |  |  |               |  |  |  |                       |  |  |  |         |               |        |                       |  |                                |        |                       |           |  |  |  |           |  |  |  |
| Signature   |                                |        |                       |  |                |  |  |  |               |  |  |  |               |  |  |  |                       |  |  |  |         |               |        |                       |  |                                |        |                       |           |  |  |  |           |  |  |  |   |                   |  |       |  |                |  |  |  |               |  |  |  |               |  |  |  |                       |  |  |  |         |               |        |                       |  |                                |        |                       |           |  |  |  |           |  |  |  |
| <table border="1" style="width: 100%; border-collapse: collapse;"> <tr> <td colspan="2"><b>SERVICE 09</b></td> <td colspan="2">Date:</td> </tr> <tr> <td colspan="4">Engineer name:</td> </tr> <tr> <td colspan="4">Company name:</td> </tr> <tr> <td colspan="4">Telephone No:</td> </tr> <tr> <td colspan="4">Gas safe register No:</td> </tr> <tr> <td>Record:</td> <td>At max. rate:</td> <td>CO ppm</td> <td>AND CO<sub>2</sub> %</td> </tr> <tr> <td></td> <td>At min. rate: (Where Possible)</td> <td>CO ppm</td> <td>AND CO<sub>2</sub> %</td> </tr> <tr> <td colspan="4">Comments:</td> </tr> <tr> <td colspan="4">Signature</td> </tr> </table> | <b>SERVICE 09</b>              |        | Date:                 |  | Engineer name: |  |  |  | Company name: |  |  |  | Telephone No: |  |  |  | Gas safe register No: |  |  |  | Record: | At max. rate: | CO ppm | AND CO <sub>2</sub> % |  | At min. rate: (Where Possible) | CO ppm | AND CO <sub>2</sub> % | Comments: |  |  |  | Signature |  |  |  | <table border="1" style="width: 100%; border-collapse: collapse;"> <tr> <td colspan="2"><b>SERVICE 10</b></td> <td colspan="2">Date:</td> </tr> <tr> <td colspan="4">Engineer name:</td> </tr> <tr> <td colspan="4">Company name:</td> </tr> <tr> <td colspan="4">Telephone No:</td> </tr> <tr> <td colspan="4">Gas safe register No:</td> </tr> <tr> <td>Record:</td> <td>At max. rate:</td> <td>CO ppm</td> <td>AND CO<sub>2</sub> %</td> </tr> <tr> <td></td> <td>At min. rate: (Where Possible)</td> <td>CO ppm</td> <td>AND CO<sub>2</sub> %</td> </tr> <tr> <td colspan="4">Comments:</td> </tr> <tr> <td colspan="4">Signature</td> </tr> </table> | <b>SERVICE 10</b> |  | Date: |  | Engineer name: |  |  |  | Company name: |  |  |  | Telephone No: |  |  |  | Gas safe register No: |  |  |  | Record: | At max. rate: | CO ppm | AND CO <sub>2</sub> % |  | At min. rate: (Where Possible) | CO ppm | AND CO <sub>2</sub> % | Comments: |  |  |  | Signature |  |  |  |
| <b>SERVICE 09</b>   |                                | Date:  |                       |  |                |  |  |  |               |  |  |  |               |  |  |  |                       |  |  |  |         |               |        |                       |  |                                |        |                       |           |  |  |  |           |  |  |  |   |                   |  |       |  |                |  |  |  |               |  |  |  |               |  |  |  |                       |  |  |  |         |               |        |                       |  |                                |        |                       |           |  |  |  |           |  |  |  |
| Engineer name:  |                                |        |                       |  |                |  |  |  |               |  |  |  |               |  |  |  |                       |  |  |  |         |               |        |                       |  |                                |        |                       |           |  |  |  |           |  |  |  |   |                   |  |       |  |                |  |  |  |               |  |  |  |               |  |  |  |                       |  |  |  |         |               |        |                       |  |                                |        |                       |           |  |  |  |           |  |  |  |
| Company name:   |                                |        |                       |  |                |  |  |  |               |  |  |  |               |  |  |  |                       |  |  |  |         |               |        |                       |  |                                |        |                       |           |  |  |  |           |  |  |  |   |                   |  |       |  |                |  |  |  |               |  |  |  |               |  |  |  |                       |  |  |  |         |               |        |                       |  |                                |        |                       |           |  |  |  |           |  |  |  |
| Telephone No:   |                                |        |                       |  |                |  |  |  |               |  |  |  |               |  |  |  |                       |  |  |  |         |               |        |                       |  |                                |        |                       |           |  |  |  |           |  |  |  |   |                   |  |       |  |                |  |  |  |               |  |  |  |               |  |  |  |                       |  |  |  |         |               |        |                       |  |                                |        |                       |           |  |  |  |           |  |  |  |
| Gas safe register No:   |                                |        |                       |  |                |  |  |  |               |  |  |  |               |  |  |  |                       |  |  |  |         |               |        |                       |  |                                |        |                       |           |  |  |  |           |  |  |  |   |                   |  |       |  |                |  |  |  |               |  |  |  |               |  |  |  |                       |  |  |  |         |               |        |                       |  |                                |        |                       |           |  |  |  |           |  |  |  |
| Record:   | At max. rate:                  | CO ppm | AND CO <sub>2</sub> % |  |                |  |  |  |               |  |  |  |               |  |  |  |                       |  |  |  |         |               |        |                       |  |                                |        |                       |           |  |  |  |           |  |  |  |   |                   |  |       |  |                |  |  |  |               |  |  |  |               |  |  |  |                       |  |  |  |         |               |        |                       |  |                                |        |                       |           |  |  |  |           |  |  |  |
|   | At min. rate: (Where Possible) | CO ppm | AND CO <sub>2</sub> % |  |                |  |  |  |               |  |  |  |               |  |  |  |                       |  |  |  |         |               |        |                       |  |                                |        |                       |           |  |  |  |           |  |  |  |   |                   |  |       |  |                |  |  |  |               |  |  |  |               |  |  |  |                       |  |  |  |         |               |        |                       |  |                                |        |                       |           |  |  |  |           |  |  |  |
| Comments:   |                                |        |                       |  |                |  |  |  |               |  |  |  |               |  |  |  |                       |  |  |  |         |               |        |                       |  |                                |        |                       |           |  |  |  |           |  |  |  |   |                   |  |       |  |                |  |  |  |               |  |  |  |               |  |  |  |                       |  |  |  |         |               |        |                       |  |                                |        |                       |           |  |  |  |           |  |  |  |
| Signature   |                                |        |                       |  |                |  |  |  |               |  |  |  |               |  |  |  |                       |  |  |  |         |               |        |                       |  |                                |        |                       |           |  |  |  |           |  |  |  |   |                   |  |       |  |                |  |  |  |               |  |  |  |               |  |  |  |                       |  |  |  |         |               |        |                       |  |                                |        |                       |           |  |  |  |           |  |  |  |
| <b>SERVICE 10</b>   |                                | Date:  |                       |  |                |  |  |  |               |  |  |  |               |  |  |  |                       |  |  |  |         |               |        |                       |  |                                |        |                       |           |  |  |  |           |  |  |  |   |                   |  |       |  |                |  |  |  |               |  |  |  |               |  |  |  |                       |  |  |  |         |               |        |                       |  |                                |        |                       |           |  |  |  |           |  |  |  |
| Engineer name:  |                                |        |                       |  |                |  |  |  |               |  |  |  |               |  |  |  |                       |  |  |  |         |               |        |                       |  |                                |        |                       |           |  |  |  |           |  |  |  |   |                   |  |       |  |                |  |  |  |               |  |  |  |               |  |  |  |                       |  |  |  |         |               |        |                       |  |                                |        |                       |           |  |  |  |           |  |  |  |
| Company name:   |                                |        |                       |  |                |  |  |  |               |  |  |  |               |  |  |  |                       |  |  |  |         |               |        |                       |  |                                |        |                       |           |  |  |  |           |  |  |  |   |                   |  |       |  |                |  |  |  |               |  |  |  |               |  |  |  |                       |  |  |  |         |               |        |                       |  |                                |        |                       |           |  |  |  |           |  |  |  |
| Telephone No:   |                                |        |                       |  |                |  |  |  |               |  |  |  |               |  |  |  |                       |  |  |  |         |               |        |                       |  |                                |        |                       |           |  |  |  |           |  |  |  |   |                   |  |       |  |                |  |  |  |               |  |  |  |               |  |  |  |                       |  |  |  |         |               |        |                       |  |                                |        |                       |           |  |  |  |           |  |  |  |
| Gas safe register No:   |                                |        |                       |  |                |  |  |  |               |  |  |  |               |  |  |  |                       |  |  |  |         |               |        |                       |  |                                |        |                       |           |  |  |  |           |  |  |  |   |                   |  |       |  |                |  |  |  |               |  |  |  |               |  |  |  |                       |  |  |  |         |               |        |                       |  |                                |        |                       |           |  |  |  |           |  |  |  |
| Record:   | At max. rate:                  | CO ppm | AND CO <sub>2</sub> % |  |                |  |  |  |               |  |  |  |               |  |  |  |                       |  |  |  |         |               |        |                       |  |                                |        |                       |           |  |  |  |           |  |  |  |   |                   |  |       |  |                |  |  |  |               |  |  |  |               |  |  |  |                       |  |  |  |         |               |        |                       |  |                                |        |                       |           |  |  |  |           |  |  |  |
|   | At min. rate: (Where Possible) | CO ppm | AND CO <sub>2</sub> % |  |                |  |  |  |               |  |  |  |               |  |  |  |                       |  |  |  |         |               |        |                       |  |                                |        |                       |           |  |  |  |           |  |  |  |   |                   |  |       |  |                |  |  |  |               |  |  |  |               |  |  |  |                       |  |  |  |         |               |        |                       |  |                                |        |                       |           |  |  |  |           |  |  |  |
| Comments:   |                                |        |                       |  |                |  |  |  |               |  |  |  |               |  |  |  |                       |  |  |  |         |               |        |                       |  |                                |        |                       |           |  |  |  |           |  |  |  |   |                   |  |       |  |                |  |  |  |               |  |  |  |               |  |  |  |                       |  |  |  |         |               |        |                       |  |                                |        |                       |           |  |  |  |           |  |  |  |
| Signature   |                                |        |                       |  |                |  |  |  |               |  |  |  |               |  |  |  |                       |  |  |  |         |               |        |                       |  |                                |        |                       |           |  |  |  |           |  |  |  |   |                   |  |       |  |                |  |  |  |               |  |  |  |               |  |  |  |                       |  |  |  |         |               |        |                       |  |                                |        |                       |           |  |  |  |           |  |  |  |

\*All installations in England and Wales must be notified to Local Authority Building Control (LABC) either directly or through a Competent Persons Scheme. A Building Regulations Compliance Certificate will then be issued to the customer.





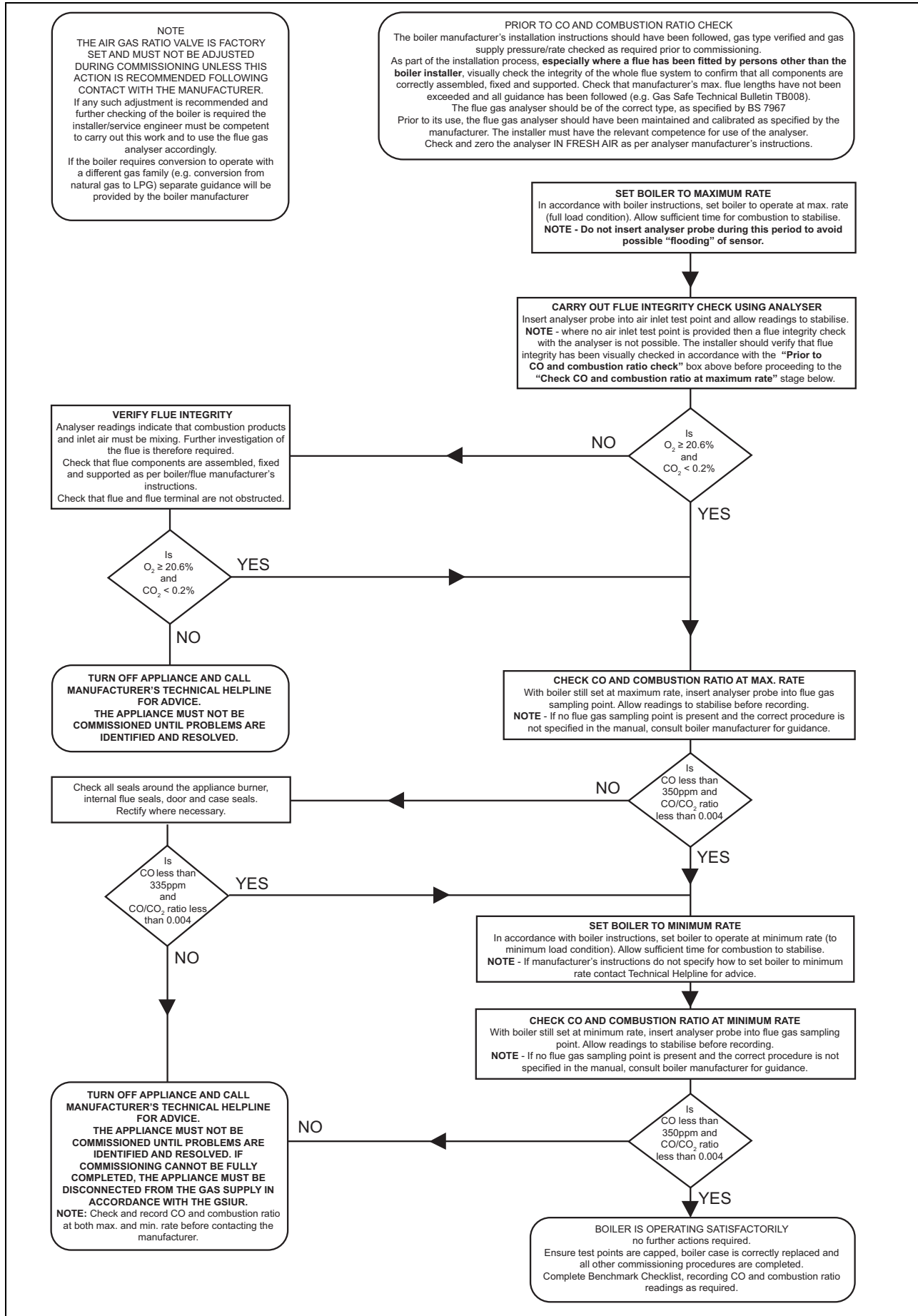

## Appendix

### I Technical data

#### Technical data – Heating

|  | VU 246/6-5 OVZ (P-GB) |
|--|-----------------------|
| Max. flow temperature adjustment range (default setting: 75 °C)                        | 10 ... 80 °C          |
| Maximum permissible pressure   | 0.3 MPa<br>(3.0 bar)  |
| Nominal water flow ( $\Delta T = 20$ K)  | 1,059 l/h             |
| Nominal water flow at Pmin ( $\Delta T = 20$ K)  | 260 l/h               |
| Nominal water flow ( $\Delta T = 30$ K)  | 706 l/h               |
| Nominal water flow at Pmin ( $\Delta T = 30$ K)  | 170 l/h               |
| Approximate value for the condensate volume (pH value between 3.5 and 4.0) at 50/30 °C | 2.47 l/h              |

#### Technical data – Power/loading G31

|   | VU 246/6-5 OVZ (P-GB) |
|---|-----------------------|
| Maximum heat output                     | 24 kW                 |
| Effective output range (P) at 40/30 °C  | 6.5 ... 26.2 kW       |
| Effective output range (P) at 50/30 °C  | 8.0 ... 25.7 kW       |
| Effective output range (P) at 80/60 °C  | 7.6 ... 24.3 kW       |
| Domestic hot water heat output (P)      | 8.0 ... 30.0 kW       |
| Maximum heat input – heating (Q max.)   | 24.7 kW               |
| Minimum heat input – heating (Q min.)   | 7.7 kW                |
| Maximum heat input – hot water (Q max.) | 30.6 kW               |
| Minimum heat input – hot water (Q min.) | 7.7 kW                |

#### Technical data – General

|   | VU 246/6-5 OVZ (P-GB)  |
|---|------------------------|
| Diameter of the gas pipe                                | 1/2 inch               |
| Diameter of the heating connections                     | 3/4 inch               |
| Expansion relief valve connector (min.)                 | 15 mm                  |
| Condensate drain pipework (min.)                        | 21.5 mm                |
| G31 gas supply pressure                                 | 3.7 kPa<br>(37.0 mbar) |
| CE number (PIN)   | CE-0063CP3646          |
| Flue gas mass rate in heating mode at P min.            | 3.4 g/s                |
| Flue gas mass rate in heating mode at P max.            | 11.0 g/s               |
| Flue gas mass rate in hot water handling mode at P max. | 13.2 g/s               |
| Flue gas temperature (80 °C/60 °C) at P max.            | 77 °C                  |
| Flue gas temperature (80 °C/60 °C) at P min.            | 55 °C                  |

|   | VU 246/6-5 OVZ (P-GB) |
|---|-----------------------|
| Flue gas temperature (50 °C/30 °C) at P max.    | 60 °C                 |
| Flue gas temperature (50 °C/30 °C) at P min.    | 35 °C                 |
| Flue gas temperature in hot water handling mode | 68 °C                 |
| Flue gas temperature when over-heating          | 95 °C                 |
| Released system types                           | C13                   |
| Nominal efficiency at 80/60 °C                  | 98.2 %                |
| Nominal efficiency at 50/30 °C                  | 102.0 %               |
| Nominal efficiency at 40/30 °C                  | 104.0 %               |
| Product dimensions, width                       | 375 mm                |
| Product dimensions, depth                       | 295 mm                |
| Product dimensions, height                      | 602 mm                |
| Net weight                                      | 23 kg                 |
| Weight when filled with water                   | 28 kg                 |

#### Technical data – Electrics

|                                      | VU 246/6-5 OVZ (P-GB) |
|--------------------------------------|-----------------------|
| Electric connection                  | 230 V / 50 Hz         |
| Built-in fuse (slow-blow)            | T2/2A, 250V           |
| Max. electrical power consumption    | 29 W                  |
| Standby electrical power consumption | 2 W                   |
| Level of protection                  | IPX4D                 |

# Index

## Index

### A

|                                |    |
|--------------------------------|----|
| Air/flue pipe, installed ..... | 4  |
| Article number .....           | 6  |
| Auxiliary relay .....          | 16 |

### B

|                                |    |
|--------------------------------|----|
| Burner anti-cycling time ..... | 20 |
|--------------------------------|----|

### C

|                                    |        |
|------------------------------------|--------|
| Calling up the fault memory .....  | 21     |
| CE label .....                     | 7      |
| Check programmes .....             | 16     |
| Checking the burner .....          | 24     |
| Cleaning the condensate trap ..... | 25     |
| Cleaning the heat exchanger .....  | 24     |
| Clearance .....                    | 8      |
| CO <sub>2</sub> content            |        |
| Checking .....                     | 19, 22 |

|                             |   |
|-----------------------------|---|
| Combustion air supply ..... | 4 |
| Competent person .....      | 3 |

|                                   |    |
|-----------------------------------|----|
| Completing inspection work .....  | 25 |
| Completing maintenance work ..... | 25 |

|                                 |    |
|---------------------------------|----|
| Condensate discharge pipe ..... | 12 |
| Contact details .....           | 16 |

|                 |    |
|-----------------|----|
| Control .....   | 14 |
| Corrosion ..... | 4  |

### D

|                                   |    |
|-----------------------------------|----|
| Decommissioning .....             | 25 |
| Decommissioning the product ..... | 25 |

|                                  |    |
|----------------------------------|----|
| Disposal, packaging .....        | 25 |
| Disposing of the packaging ..... | 25 |

|                            |    |
|----------------------------|----|
| Documents .....            | 6  |
| Draining the product ..... | 25 |

### E

|                                      |    |
|--------------------------------------|----|
| Electricity .....                    | 4  |
| Ending, installation assistant ..... | 16 |

### F

|                    |        |
|--------------------|--------|
| Fault codes .....  | 20, 33 |
| Filling mode ..... | 16     |

|  |    |
|--|----|
| Filling the condensate trap .....      | 18 |
| Filling the heating installation ..... | 18 |

|                            |   |
|----------------------------|---|
| Flue gas route .....       | 4 |
| Front casing, closed ..... | 4 |

|             |   |
|-------------|---|
| Frost ..... | 5 |
|-------------|---|

### G

|                     |    |
|---------------------|----|
| Gas flow rate ..... | 18 |
| Gas type .....      | 11 |

### H

|                                    |    |
|------------------------------------|----|
| Handing over to the end user ..... | 20 |
| Heating partial load .....         | 16 |

|                             |    |
|-----------------------------|----|
| Hot water temperature ..... | 16 |
|-----------------------------|----|

### I

|                             |   |
|-----------------------------|---|
| Identification plate .....  | 6 |
| If you smell flue gas ..... | 4 |

|                        |    |
|------------------------|----|
| If you smell gas ..... | 3  |
| Inspection work .....  | 22 |

|   |    |
|---|----|
| Installation assistant, ending .....      | 16 |
| Installation assistants, restarting ..... | 16 |

|                                   |    |
|-----------------------------------|----|
| Installation site .....           | 4  |
| Installer level, calling up ..... | 15 |

|                                   |   |
|-----------------------------------|---|
| Installing the front casing ..... | 9 |
| Installing the side section ..... | 9 |

|                    |   |
|--------------------|---|
| Intended use ..... | 3 |
|--------------------|---|

### L

|                      |            |
|----------------------|------------|
| Language .....       | 15         |
| Leak-tightness ..... | 19, 22, 25 |

|                  |       |
|------------------|-------|
| Liquid gas ..... | 4, 11 |
|------------------|-------|

### M

|                        |    |
|------------------------|----|
| Mains connection ..... | 14 |
| Maintenance work ..... | 22 |

|                               |    |
|-------------------------------|----|
| Minimum clearance .....       | 8  |
| Multi-functional module ..... | 16 |

### O

|                            |    |
|----------------------------|----|
| Open-flued operation ..... | 4  |
| Operating concept .....    | 15 |

### P

|                                 |    |
|---------------------------------|----|
| Power supply .....              | 14 |
| Preparing the repair work ..... | 21 |

|                              |    |
|------------------------------|----|
| Preparing, repair work ..... | 21 |
|------------------------------|----|

### Q

|                     |   |
|---------------------|---|
| Qualification ..... | 3 |
|---------------------|---|

### R

|                                    |    |
|------------------------------------|----|
| Regulations .....                  | 5  |
| Removing the air intake pipe ..... | 23 |

|                           |    |
|---------------------------|----|
| Removing the burner ..... | 23 |
|---------------------------|----|

|                              |    |
|------------------------------|----|
| Removing the flue pipe ..... | 23 |
|------------------------------|----|

|   |    |
|---|----|
| Removing the gas-air mixture unit ..... | 23 |
|---|----|

|                                 |   |
|---------------------------------|---|
| Removing the side section ..... | 9 |
|---------------------------------|---|

|                            |    |
|----------------------------|----|
| Replacing the burner ..... | 21 |
|----------------------------|----|

|                                    |    |
|------------------------------------|----|
| Replacing the heat exchanger ..... | 21 |
|------------------------------------|----|

|                              |    |
|------------------------------|----|
| Replacing the main PCB ..... | 22 |
|------------------------------|----|

|  |    |
|--|----|
| Resetting the burner anti-cycling time ..... | 20 |
|--|----|

### S

|                     |   |
|---------------------|---|
| Safety device ..... | 4 |
|---------------------|---|

|                         |   |
|-------------------------|---|
| Schematic drawing ..... | 4 |
|-------------------------|---|

|                     |   |
|---------------------|---|
| Serial number ..... | 6 |
|---------------------|---|

|  |    |
|--|----|
| Setting the burner anti-cycling time ..... | 20 |
|--|----|

|                   |    |
|-------------------|----|
| Spare parts ..... | 20 |
|-------------------|----|

|   |    |
|---|----|
| Starting, installation assistants ..... | 16 |
|---|----|

|                    |    |
|--------------------|----|
| Status codes ..... | 15 |
|--------------------|----|

|                                |    |
|--------------------------------|----|
| Switching on the product ..... | 18 |
|--------------------------------|----|

### T

|                               |    |
|-------------------------------|----|
| Target flow temperature ..... | 16 |
|-------------------------------|----|

|  |    |
|--|----|
| Telephone number, competent person ..... | 16 |
|--|----|

|                       |    |
|-----------------------|----|
| Test programmes ..... | 16 |
|-----------------------|----|

|            |   |
|------------|---|
| Tool ..... | 5 |
|------------|---|

|                 |   |
|-----------------|---|
| Transport ..... | 4 |
|-----------------|---|

|                    |   |
|--------------------|---|
| Transporting ..... | 7 |
|--------------------|---|

|                                  |    |
|----------------------------------|----|
| Treating the heating water ..... | 16 |
|----------------------------------|----|

### U

|                         |   |
|-------------------------|---|
| Unloading the box ..... | 7 |
|-------------------------|---|

|                             |   |
|-----------------------------|---|
| Unpacking the product ..... | 7 |
|-----------------------------|---|

|   |    |
|---|----|
| User interface, replacing the PCB ..... | 22 |
|---|----|

### V

|               |   |
|---------------|---|
| Voltage ..... | 4 |
|---------------|---|

### W

|                                 |   |
|---------------------------------|---|
| Wall-mounting the product ..... | 8 |
|---------------------------------|---|

|              |   |
|--------------|---|
| Weight ..... | 8 |
|--------------|---|









0020239015\_05

0020239015\_05 ■ 06.06.2018

**Supplier**

**Vaillant Ltd.**

Nottingham Road ■ Belper ■ Derbyshire ■ DE56 1JT

Telephone 0330 100 3461

info@vaillant.co.uk ■ www.vaillant.co.uk

© These instructions, or parts thereof, are protected by copyright and may be reproduced or distributed only with the manufacturer's written consent.

We reserve the right to make technical changes.