

For the competent person

Installation Manual

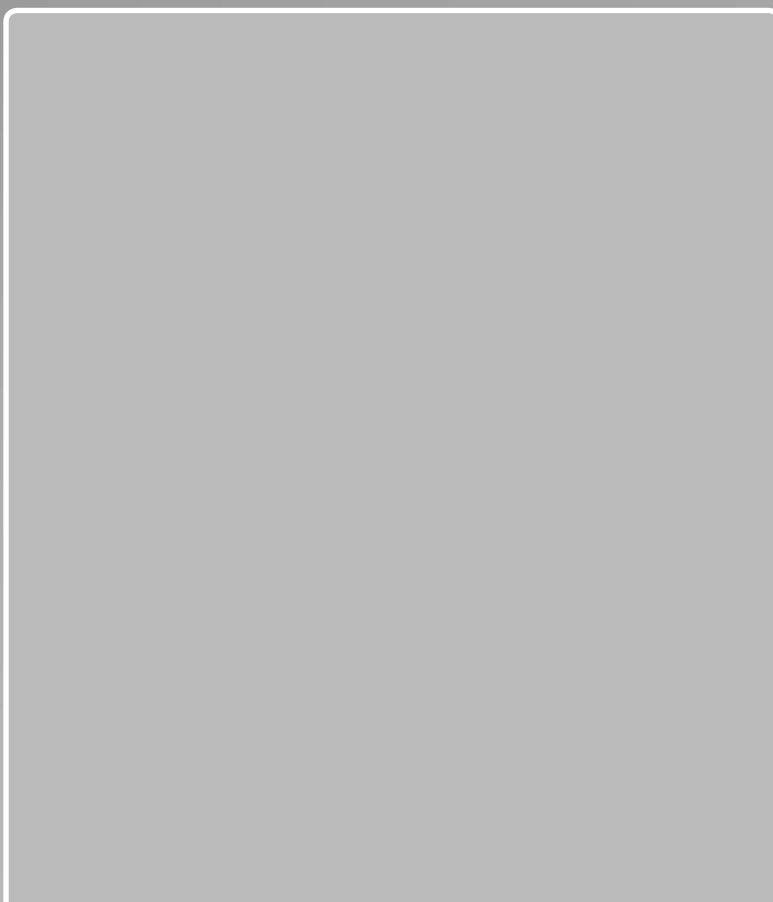

Flue pipe for ecoTEC plus

Concentric Ø 110/160

GB, IE

Table of contents

Table of contents

		10	Installing the horizontal flue gas pipe Ø 110/160 mm.....	27
			Index.....	30
1	Notes on the documentation	3		
1.1	Observing other applicable documents	3		
1.2	Storing documents	3		
1.3	Applicability of the instructions	3		
2	Safety	4		
2.1	Classification of action-related warnings	4		
2.2	General safety information	4		
2.3	Intended use.....	5		
2.4	Regulations	5		
2.5	CE certification	5		
3	Installation dimensions	6		
4	System overview of concentric system Ø 110/160 mm	7		
4.1	Installation options	7		
4.2	Product range	9		
4.3	Elements	9		
4.4	Description of elements	11		
5	System conditions.....	15		
5.1	Maximum pipe lengths	15		
5.2	Performance features of the flue pipes from Vaillant for condensing units	16		
5.3	Requirements for the shaft for the flue pipe	16		
5.4	Location of the opening.....	16		
5.5	Disposing of condensate	16		
5.6	Route of the flue pipe in the building.....	16		
6	Installation of the vertical roof duct	17		
6.1	Installation instructions	17		
6.2	Installing the roof duct.....	17		
6.2.1	Black roof duct.....	17		
6.2.2	Stainless steel roof duct.....	18		
7	Installing the concentric connection to the air/flue gas system (LAS).....	19		
8	Installing the flue gas pipe on the external wall	20		
8.1	System diagram	20		
8.2	Static dimensions	20		
8.3	Installing the flue gas pipe	21		
8.3.1	Installation instructions	21		
8.3.2	Installing the connection for the external wall pipe.....	22		
8.3.3	Installing the clamps	24		
8.3.4	Installing the roof duct.....	24		
8.3.5	Shortening an extension.....	25		
9	Installing the horizontal wall duct.....	26		
9.1	System diagram	26		
9.2	Installing the wall duct.....	26		
9.3	Installing the horizontal wall duct.....	27		

1 Notes on the documentation

1.1 Observing other applicable documents

For the competent person:

- Installation instructions for the installed gas-fired boiler.

1.2 Storing documents

- > Please pass on this installation manual and all other applicable documents and auxiliary equipment to the plant operator.

The system operator will store these instructions as well as any auxiliary materials so that they are available when required.

1.3 Applicability of the instructions

This installation manual applies only for the Vaillant units named in the other applicable documents.



2 Safety

2.1 Classification of action-related warnings

The action-related warnings are classified in accordance with the severity of the possible danger using the following warning symbols and signal words:

Warning symbol	Signal word	Explanation
	Danger!	Imminent danger to life or risk of severe personal injury
	Danger!	Risk of death from electric shock
	Warning.	Risk of minor personal injury
	Caution.	Risk of material or environmental damage

2.1 Meaning of warning symbols

2.2 General safety information

- Before installing the flue pipe, you must inform the local gas supply company and the master chimney sweep for the district.

Qualification of the competent persons

The installation of the boiler and its flue must be carried out by a competent person approved at the time by the Health and Safety Executive. This competent person is also responsible for proper execution. They must also comply with the existing directives, regulations and guidelines.

Dangers caused by flue gas exit in the event of improper installation.

In the event of improper installation, there is a risk that poisonous gases may be emitted.

- Ensure that the installation is performed only by qualified competent persons.

Risk of death by poisoning due to escaping flue gases!

All openings in the flue pipe that can be opened for inspection purposes must be closed before start-up and during operation.

- The openings must only be opened by a competent person. For open-flued operation, the unit must not be placed in rooms from which the air is extracted using fans (for example, ventilation systems, extractor hoods, tumble dryer ventilation). These systems generate negative pressure in the room. This negative pressure can cause flue gas to be sucked into the installation room from the opening through the annular clearance between the flue gas pipe and the shaft. The unit can be used in open-flued operation if simultaneous operation of the unit and the fan is not possible.

Avoid risk of suffocation!

If the flue gas pipe is not concentric and is therefore not ventilated from behind, there is a danger of suffocation in unventilated rooms.

- These rooms must be equipped with a ventilation opening of 150 cm² that leads into the fresh air.

Prevent injuries caused by snow falling from roofs

Where flue pipes penetrate the roof skin, the water vapour contained in flue gas may precipitate as ice on the roof or the roof structures in unfavourable weather conditions.

- At the installation site, ensure that this ice build-up does not slide from the roof.

Use of tools

Unsuitable tools or the improper use of tools can cause damage (e. g. to casing and components).

- Always use appropriate screwdrivers or open-end spanners (fork wrenches) to loosen or tighten threaded connections.
- Never use pipe wrenches, extensions, or other similar tools.

Preventing the risk of corrosion in the flue gas installation

Sprays, solvents, cleaning agents, paints and adhesives may contain substances that could lead to corrosion in the flue gas installation in some circumstances when the unit is in operation.

- Only use appropriate Vaillant components for installing the flue gas guiding.
- Ensure that the combustion air that is guided to the unit is kept free of chemical substances that could contain, e. g. fluorine, chlorine, or sulphur.

Preventing electronic damage and risk of fire caused by lightning

The unit can be damaged by the effects of lightning.

- If the building is equipped with a lightning protection system, incorporate the air/flue gas pipe into the lightning protection.
- If the vertical flue gas pipe contains materials made from metal, incorporate it into the potential balancing.



Malfunctions of the unit due to obstruction of the flue gas flow!

If chippings, mortar residue, or similar objects enter the flue pipe, the function of the unit may be affected.

- During installation, ensure that no chippings, mortar residue, etc. remain in the flue pipe.

Malfunctions and condensation exit due to lack of tightness in the flue gas route!

The seals are sensitive to mineral-oil-based grease.

- If necessary, use either water or the lubricant provided.

Fire protection

Outside the shaft, the flue gas pipes that are not in a concentric design must have a minimum clearance of 5 cm to combustible components. In chimneys formerly used for oil or solid fuels, which are now to be used for the supply of combustion air, it is recommended that the chimney sweep inspects and cleans the flue in question before the flue gas pipe is installed. If it is not possible to adequately clean or inspect the chimney (e. g. due to construction features), you can

- use a separated air supply
- or
- use open-flued operation for the system.



It is not necessary to leave a clearance between the concentric flue pipe or the corresponding extension and components made from combustible materials, because, at the nominal heat output of the unit, components bordering the surface cannot reach temperatures higher than 85°C.

2.3 Intended use

The Vaillant flue pipes for ecoTEC plus are constructed using state-of-the-art technology in accordance with the recognised safety rules and regulations. Nevertheless, there is still a risk of death or serious injury to the user or others or of damage to the unit and other property in the event of improper use or use for which the unit is not intended.

The Vaillant flue pipes named in this manual must only be used in combination with the unit types named in this manual.

Any other, or additional use is considered improper use and all responsibility or liability of the manufacturer/supplier for any resulting damages is excluded. In this case, the responsible competent person and the user bear the risk.

Intended use includes the following:

- Observance of accompanying operating, installation and servicing instructions for Vaillant products as well as for other parts of components of the system
- Installing and fitting the boiler in accordance with the boiler and system approval
- Compliance with all inspection and maintenance conditions listed in the instructions.

2.4 Regulations

Observe the national regulations, standards, guidelines and laws.

2.5 CE certification

The heat generators are certified as gas-fired boilers with associated flue systems in accordance with the Gas Appliances Regulation (EU) 2016/426. This set-up instructions are a component of the certification and are cited in the type testing certificate. In compliance with the regulatory statutes of these setup instructions, the proof of usability of the elements identified by Vaillant article numbers that are designed for the air/flue pipe is provided. If you do not use certified elements for the Vaillant air/flue pipe when installing the heat generators, this voids the CE conformity of the heat generator. We therefore strongly recommend that you fit Vaillant air/flue systems.

3 Installation dimensions

3 Installation dimensions

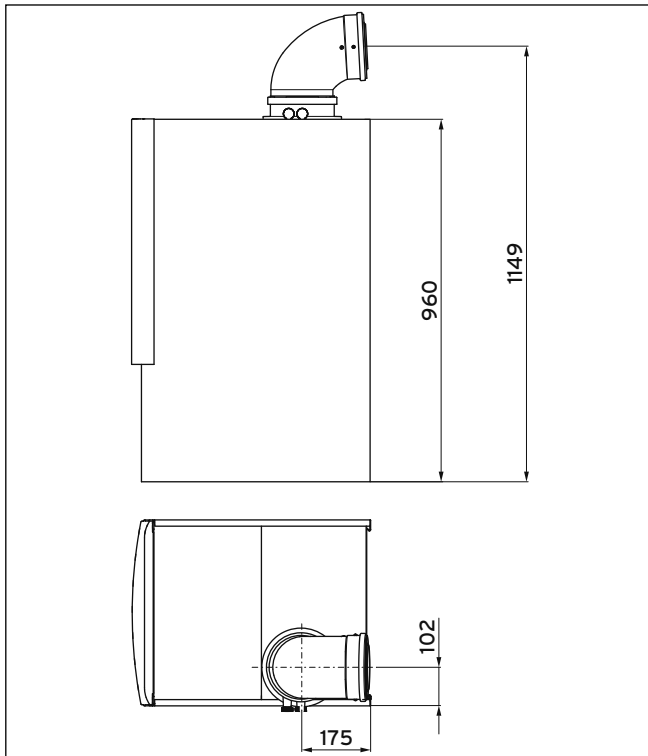

3.1 Installation dimensions

4 System overview of concentric system Ø 110/160 mm

4.1 Installation options

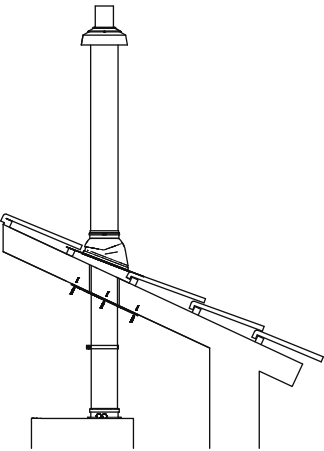
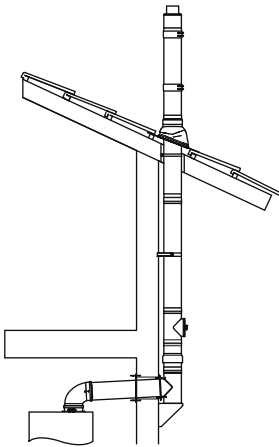
	Required art. no. *)	Type of installation	Installation instructions
	0020166853 (black)	Vertical roof duct: concentric air/flue gas pipe through the roof	Maximum pipe lengths: → section 5.1 Installing the vertical roof duct: → section 6
	0020166855	Concentric connection to the flue gas pipe on the external wall Combustion air from outside In accordance with the construction regulation, installation in buildings higher than 18 m is not permitted.	Maximum pipe lengths: → section 5.1 Installing the flue gas pipe on the external wall: → section 8 Installing the horizontal flue gas pipe: → section 10
	0010035928	Concentric connection to the flue gas pipe on the external wall, stainless steel In accordance with the construction regulation, installation in buildings higher than 18 m is permitted.	

4.1 Installation options (continued on next page)

4 System overview of concentric system Ø 110/160 mm

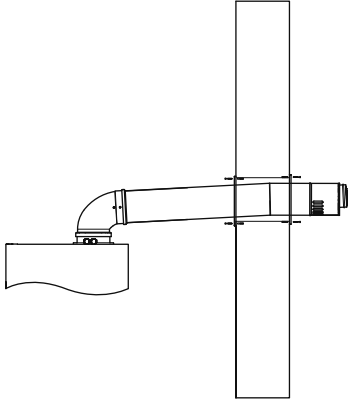
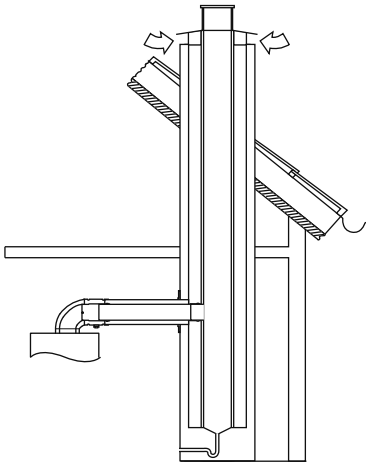
	Required art. no. *)	Type of installation	Installation instructions
	0020166854	Concentric horizontal wall duct In accordance with the construction regulation, installation in buildings higher than 18 m is not permitted.	Maximum pipe lengths: → section 5.1 Installing the horizontal wall duct: → section 9 Installing the horizontal flue gas pipe: → section 10
	0010035927	Concentric horizontal wall duct, stainless steel In accordance with the construction regulation, installation in buildings higher than 18 m is permitted.	
	0020106380 with 0020106376	Concentric connection to vertical shaft system	Maximum pipe lengths: → section 5.1 Installing the concentric connection to the air/flue gas system (LAS): → section 7

*) for additional flue components, see **→ section 4.2**

4.1 Installation options (continued)













System overview of concentric system Ø 110/160 mm 4

4.2 Product range

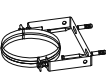
Product range	Art. no.
Vertical roof duct, black (RAL 9005)	0020166853
Horizontal wall/roof duct	0020166854, 0010035927
Connection to flue gas pipe, concentric, for laying on external wall	0020166855, 0010035928
Connection to air/flue gas system (LAS)	0020106380 with 0020106376



4.1 Product range

4.3 Elements

Elements		Art. no.	0020166853	0020166854 0010035927	0020166855 0010035928	0020106380 mit 0020106376
Extensions, concentric 0.5 m, Ø 110/160, PP		0020106376	X	X	X	X
Extensions, concentric 1.0 m, Ø 110/160, PP		0020106377	X	X	X	X
Extensions, concentric 2.0 m, Ø 110/160, PP		0020106378	X	X	X	X
Elbow 45°, concentric (x 2), Ø 110/160, PP		0020106379	X	X	X	X
Elbow 87°, concentric Ø 110/160, PP		0020106380	X	X	X	X
Fastening clamps with bolts and rawl plugs (5 pcs), Ø 160		0020106381	X	X	X	X
External wall bracket (adjustable 50 to 90 mm clearance), stainless steel		0020106400			X	
Extension for external wall bracket (adjustable 90 to 280 mm clearance), stainless steel		0020106401			X	
0.5 m extension for external wall laying, concentric, interior PP, exterior stainless steel		0020106402			X	
1.0 m extension for external wall laying, concentric, interior PP, exterior stainless steel		0020106403			X	
45° elbow for external wall laying (2 pcs), concentric, interior PP, exterior stainless steel		0020106405			X	
30° elbow for external wall laying (2 pcs), concentric, interior PP, exterior stainless steel		0020106406			X	

4.2 Elements (continued on next page)

4 System overview of concentric system Ø 110/160 mm

Elements		Art. no.	0020166853	0020166854	0020166855	0020106380 mit 0020106376
Roof duct conc., 1000 mm with rain penetration collar, Ø 110/160		0020106408			X	
Air clamp for Ø 110/160, stainless steel		0020143394			X	
Pitched roof tile 25° - 50°, flexible, black (RAL 9005)		0020106409	X		X	
Flat roof penetration collar		0020106411	X		X	

4.2 Elements (continued)

System overview of concentric system Ø 110/160 mm 4

4.4 Description of elements

Name	Art. no.	Elements
Extensions concentric, Ø 110/160, PP: - 0.5 m - 1.0 m - 2.0 m	0020106376 0020106377 0020106378	
Elbow 45° concentric (2 pcs), Ø 110/160, PP	0020106379	
Elbow 87° Concentric, Ø 110/160, PP	0020106380	
Fastening clamps with bolts and rawl plugs (5 pcs), Ø 110 mm	0020106381	
External wall bracket (adjustable 50 mm to 90 mm clearance), stainless steel	0020106400	

4.3 Description of elements (continued on next page)

4 System overview of concentric system Ø 110/160 mm

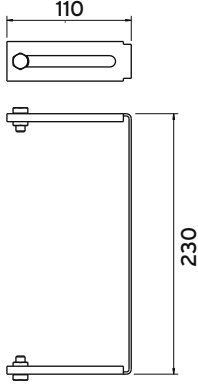
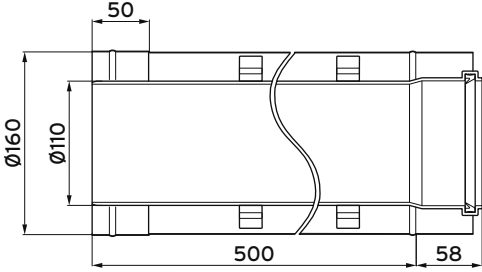
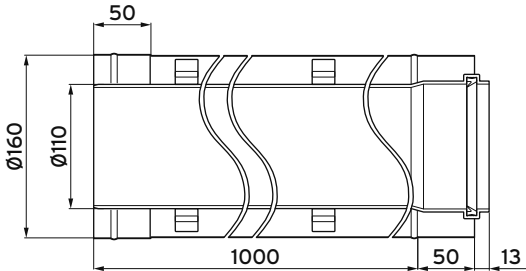
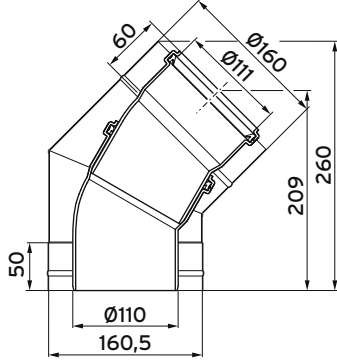
Name	Art. no.	Elements
Extension for external wall bracket (adjustable 60 to 175 mm clearance), stainless steel	0020106401	
Extension for external wall laying concentric, interior PP, exterior stain- less steel, Ø 110/160, 0.5 m	0020106402	
Extension for external wall laying concentric, interior PP, exterior stain- less steel, Ø 110/160, 1.0 m	0020106403	
Elbow 45° for external wall laying (2 pcs) concentric, interior PP, exterior stain- less steel, Ø 110/160	0020106405	

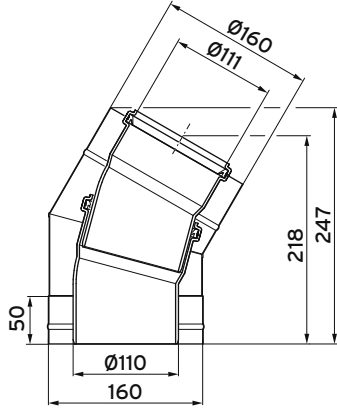
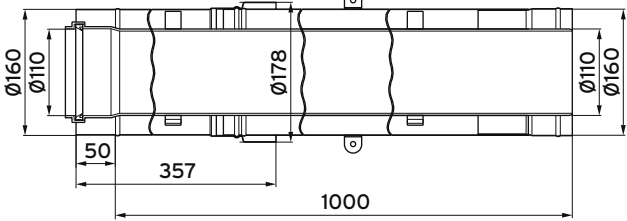
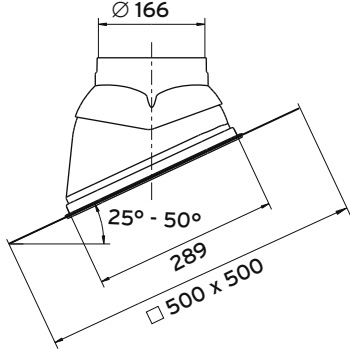
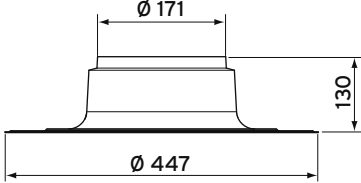

4.3 Description of elements (continued on next page)

System overview of concentric system Ø 110/160 mm 4

Name	Art. no.	Elements
Elbow 30° for external wall laying (2 pcs), concentric, interior PP, exterior stainless steel, Ø 110/160	0020106406	
Roof duct 1000 mm with rain penetration collar, concentric, Ø 110/160	0020106408	
Pitched roof tile 25°-50° flexible, black (RAL 9005) red (RAL 8023)	0020106409 0020106410	
Flat roof penetration collar	0020106411	

4.3 Description of elements (continued on next page)

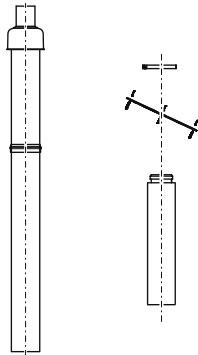
4 System overview of concentric system Ø 110/160 mm

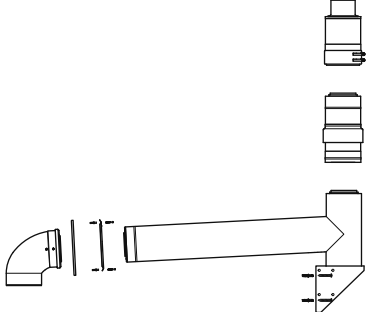
Name	Art. no.	Elements
<p>Vertical roof duct black, concentric, mounting bar, length above roof approx. 0,6 m, length below roof approx. 1,4 m - Roof duct Ø 110/160, with slider - Rafter mounting - Cover plate</p>	0020166853	
<p>Horizontal wall/roof duct concentric, with elbow and wall col- lars</p>	0020166854 0010035927	
<p>Connection to flue gas pipe, con- centric, for laying on external wall - Elbow conc., dia. 110/160, 87° Vaillant white - Wall duct, dia. 110/160, 0.5 m with external wall console, dia. 110/160 - Cover plate, Ø 160, stainless steel - Cover plate, Ø 160, steel - Supply air supports, conc., Ø 110/160 - Opening cover, Ø 110/160</p>	0020166855 0010035928	

4.3 Description of elements

5 System conditions

5.1 Maximum pipe lengths

Elements	Art. no.		ecoTEC plus		
			VU GB 806/5-5	VU GB 1006/5-5	VU GB 1206/5-5
Vertical roof duct	0020166853	Max. concentric pipe length	24 m plus 2 x 87° elbows	20 m plus 2 x 87° elbows	11 m plus 2 x 87° elbows
<p>If additional diversions are arranged in the flue gas installation, the maximum pipe length is reduced as follows:</p> <ul style="list-style-type: none"> - By 1.5 m for each 87° elbow - By 1.0 m for each 45° elbow 					
Horizontal wall/roof duct	0020166854 0010035927	Max. concentric pipe length	22 m plus 1 x 87° elbow	18 m plus 1 x 87° elbow	9 m plus 1 x 87° elbow
<p>If additional diversions are arranged in the flue gas installation, the maximum pipe length is reduced as follows:</p> <ul style="list-style-type: none"> - By 1.5 m for each 87° elbow - By 1.0 m for each 45° elbow 					
Connection to air/flue gas system (LAS)	0020106380 0020106376	Max. concentric pipe length (horizontal section)	4.0 m plus 3 x 87° elbows	4.0 m plus 3 x 87° elbows	4.0 m plus 3 x 87° elbows
<p>The chimney sweep approvals must be observed. The dimensions of the chimney must comply with the manufacturer's specifications.</p>					
Connection to flue gas pipe on the external wall	0020166855 0010035928	Max. concentric pipe length up to air intake	3 m plus 3 x 87° elbows and support elbow	3 m plus 1 x 87° elbow and support elbow	2 m plus 1 x 87° elbow and support elbow
<p>If additional extensions/diversions are arranged in the concentric part of the flue gas installation, the maximum length of the flue gas pipe on the external wall is reduced as follows:</p> <ul style="list-style-type: none"> - By 5.3 m for each 87° elbow - By 3.2 m for each 45° elbow - By 3.2 m for each 1 m extension 					
		max. pipe length on the external wall	50 m	50 m	29 m
<p>If additional diversions are arranged in the flue gas pipe on the external wall, the maximum length is reduced as follows:</p> <ul style="list-style-type: none"> - By 1 m for each 87° elbow - By 0.5 m for each 45° elbow 					

5.1 Maximum pipe lengths ecoTEC plus (continued on next page)

5 System conditions

5.2 Performance features of the flue pipes from Vaillant for condensing units

The air/flue gas systems from Vaillant demonstrate the following performance features:

Performance feature	Description
Temperature resistance:	Adapted to the maximum flue gas temperature of the unit
Leak-tightness:	Adapted to the unit for use in buildings and outdoors
Condensate resistance:	Yes, for gas and oil
Corrosion resistance:	Adapted to the gas and oil condensing boiler
Clearance from combustible materials:	- Concentric flue gas pipe: No clearance required - Non-concentric flue gas pipe: 5 cm
Installation site:	In accordance with the installation instructions
Resistance to fire:	Normal level of flame resistance (in accordance with EN 13501-1 Class E)
Fire resistance time:	No, the external pipes of the concentric system are not flammable. A required fire resistance time is provided by shafts within the building.

5.2 Performance features

5.3 Requirements for the shaft for the flue pipe

Flue pipes from Vaillant do not have any fire resistance (direction of operation from the outside to the inside).

If the flue pipe is guided through parts of a building that require a level of fire resistance, a shaft must be fitted. The shaft must ensure the fire resistance (direction of operation from the outside to the inside) that is required for the building parts through which the flue gas installation is guided. The required fire resistance must demonstrate a suitable classification (brick partition and heat insulation) and be sufficient for the building's requirements.

Observe the national ordinances, regulations and standards. An existing chimney that was used for the flue gas evacuation usually meets these requirements and can be used as a shaft for the flue pipe.

The gas tightness of the shaft must comply with the test pressure class N2 in accordance with EN 1443.

An existing chimney that was used for the flue gas evacuation usually meets these requirements and can be used as a shaft for the air guiding.

If the shaft is used to supply combustion air, this must be designed and, in particular, insulated in such a way that no moisture (caused by the cooling of the shaft by cold combustion air penetrating from the outside) can penetrate the exterior of the shaft.

An existing chimney that was used for the flue gas evacuation usually meets these requirements and can be used as a shaft for the air guiding without the need for additional heat insulation.

5.4 Location of the opening

Align the opening of the flue gas installation in such a way that ensures a secure outward flow and distribution of the flue gases and prevents these gases from re-entering the building through openings (windows, air intake openings and balconies).

The location of the flue gas installation opening must comply with the relevant applicable international, national and/or local regulations.

5.5 Disposing of condensate

When disposing of the condensate into the public wastewater system, observe the local regulations.

Local regulations may stipulate the minimum quality of any condensate that may enter the waste-water system, for example, through using a condensate neutraliser. Only use corrosion-resistant piping material for removing condensate.

5.6 Route of the flue pipe in the building

The route of the flue pipe should correspond to the shortest and the most direct distance between the unit and the flue gas installation opening, and it should run as straight as possible. Do not arrange several diversions immediately after each other.

Lay the flue pipe separately from the drinking water pipes. As a result of standards relating to the hygiene of drinking water, water pipes must be protected against impermissible heating.

The entire length of the flue gas route must be inspected and, if required, cleaned.

It must be possible to remove the flue pipe again with a minimal amount of effort (no time-consuming mortising work in the living area, but screwed-in cladding instead). If they are arranged in shafts, they are usually easy to remove.

6 Installation of the vertical roof duct

6.2 Installing the roof duct

6.1 Installation instructions



You can also use the roof ducts of the external wall system (stainless steel).



Caution.
Risk of damage to the unit.
Very damp air escapes from the channel vents. This can condense in the air pipe and cause damage to the unit.
➤ Observe the requirements for minimum clearances in (→ Fig. 6.1).

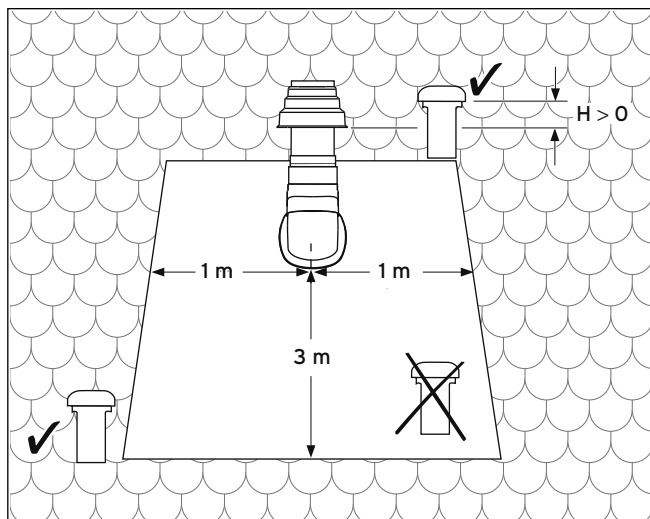

6.1 Installation site of the roof duct

6.2.1 Black roof duct

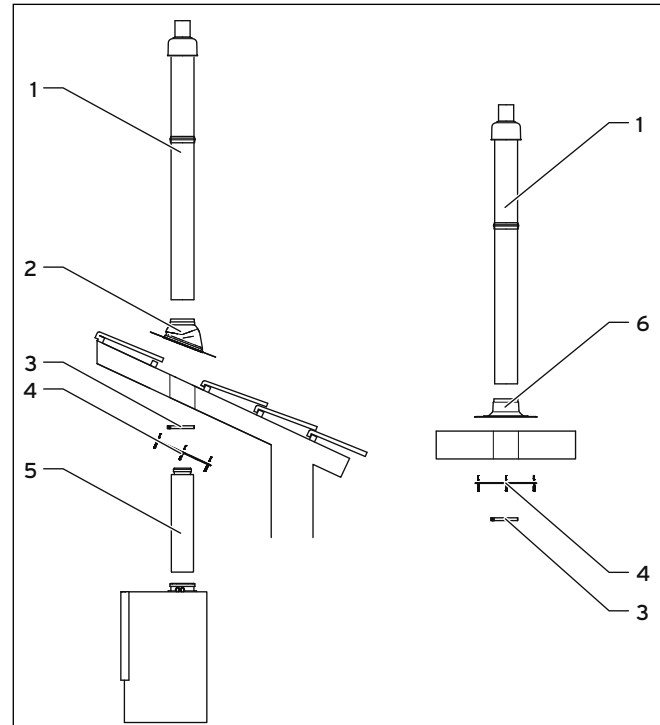

6.2 Installing the roof duct



The installation is described using an example of a pitched roof. For a flat roof, use the flat roof penetration collar (6) instead of the flat roof penetration collar (2).

- Insert the universal tile (2) in the roof.
- Insert the top part of the tile for vertical alignment of the roof duct.
- Insert the vertical roof duct (1) into the pitched roof tile (2) or the flat roof penetration collar from above. The rain penetration collar and the top part of the tile must form a rainproof seal.
- Align the roof duct vertically and secure the clamp (3) to a rafter or to the ceiling.
- Fill the gap between the roof duct and the roof or ceiling construction with insulating material.
- Screw the rosette pipe trim (vapour barrier) (4) to the ceiling. For a better seal, silicone may be used between the flange and the ceiling.

6 Installation of the vertical roof duct

You can shorten the roof duct if necessary.



Always shorten the interior and exterior pipes by an equal amount.

The slider (5) facilitates a simple connection between the roof duct and unit connection. The slider has a maximum usable length of 500 mm. This does not require shortening, because it slides telescopically into the roof duct.

- Insert the slider into the roof duct.
- If necessary, shorten the flue pipe
- Place the flue pipe and the sleeve on the flue pipe of the roof duct.
- Slide the flue pipes into the roof duct.
- Insert the flue pipes into the equipment connection piece from above.
- Remove the slider from the roof duct.
- Insert the slider into the sleeve of the equipment connection piece.
- If necessary, use concentric extensions and diversions.
- Secure all connecting points with a safety screw as described in → **section 10**.

6.2.2 Stainless steel roof duct

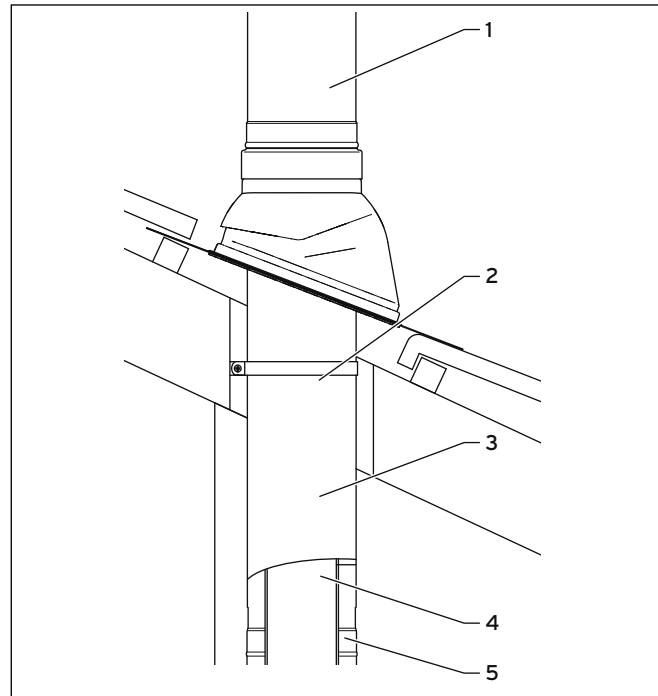

6.3 Stainless steel roof duct

Key

- 1 Roof duct
- 2 Fastening clamp
- 3 External pipe of the roof duct
- 4 Internal pipe of the roof duct
- 5 Connecting sleeve

In order to shorten the roof duct, you must first remove the connecting sleeve.

- Pull the connecting sleeve (5) from the external pipe (3). The connecting sleeve is no longer required.
- Shorten the external pipe and flue pipe by an equal distance.
- Place the roof duct on the pitched roof tile or flat roof penetration collar.
- Fit the air intake piece and the opening cover, along with the required clamps, to the upper end of the roof duct. For the air intake piece and opening cover, you must use the article number 0020106375.
- Attach the fastening clamps of the roof duct to the rafters or to the ceiling.



For the area above the roof, refer to → section 8 (roof duct in external wall system).

- Continue as described in → **section 6.2.1** (black roof duct).

7 Installing the concentric connection to the air/flue gas system (LAS)

You require at least:

- The 87° elbow, dia. 110/160 mm (article number 0020106380)
- An extension Ø 110/160 mm (article number 0020106385)



Danger!
Risk of poisoning due to escaping flue gas!

Standing condensate can damage the seals of the flue gas pipe.

- Lay the horizontal flue pipe with a downward gradient of 3° inwards. 3° corresponds to a downward gradient of approx. 50 mm per metre of pipe length.



Danger!
Risk of poisoning due to escaping flue gas!

In the event of overpressure in the vertical part of the flue gas pipe, flue gas may flow into a unit that is not operating. The units are not suitable for this mode of operation and are not checked.

- Provide evidence of the functional reliability of the vertical flue gas pipe in accordance with EN 13384 using the specifications for flue gas temperature and flue gas mass rate from the installation instructions for the unit.



Danger!
Risk of injury due to damage to the structural integrity.

The static function and fire-protective function of the shaft wall may be impaired and may lead to a hazard to persons.

- Do not attach any fastenings using bolts, rawl plugs, etc. directly to the shaft wall of the air/flue gas system.
- Do not attach fastenings to primary walling or sideways to the wall.
- Observe the specifications provided by the manufacturer of the air/flue gas system.

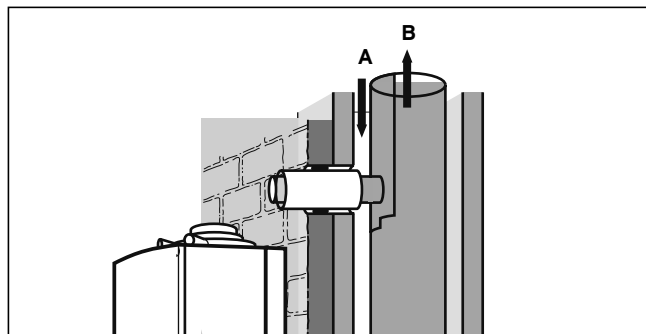

7.1 Shorten the flue pipe to the length required and insert the air pipe

Key

- A Air
- B Flue gas

- On the air/flue gas system, establish a connection in accordance with the dimensions in → **section 3**. These dimensions allow for the lateral installation of the unit or installation directly on the primary walling.

Ceramic air/flue gas systems are usually equipped with rubber sealing sleeves and have a pipe stop on the air-side connection.

- Separate the sleeve on the flue pipe so that you can slide the flue pipe into the seal.
- Insert the air pipe into the sleeve of the air/flue gas system.
- Insert the flue pipe into the flue seal of the air/flue gas system. When fitting further elements, prevent the flue pipe from sliding into the flue gas duct.

Metal air/flue gas systems feature cylindrical supports on the flue-gas-side. In this case, insert the concentric flue pipe with sleeve.



For air/flue gas system shafts that have no sleeves, you must secure the air pipe using mortar and seal the shaft.

- If applicable, install additional extensions and elbows starting from the wall and working towards the unit.
- Attach one fastening clamp for each extension.
- Finally, insert the elbow of the flue gas pipe into the flue gas connection of the unit.
- Connect all connecting points of the air pipes using a safety screw as described in → **section 10**.

8 Installing the flue gas pipe on the external wall

8 Installing the flue gas pipe on the external wall

8.1 System diagram

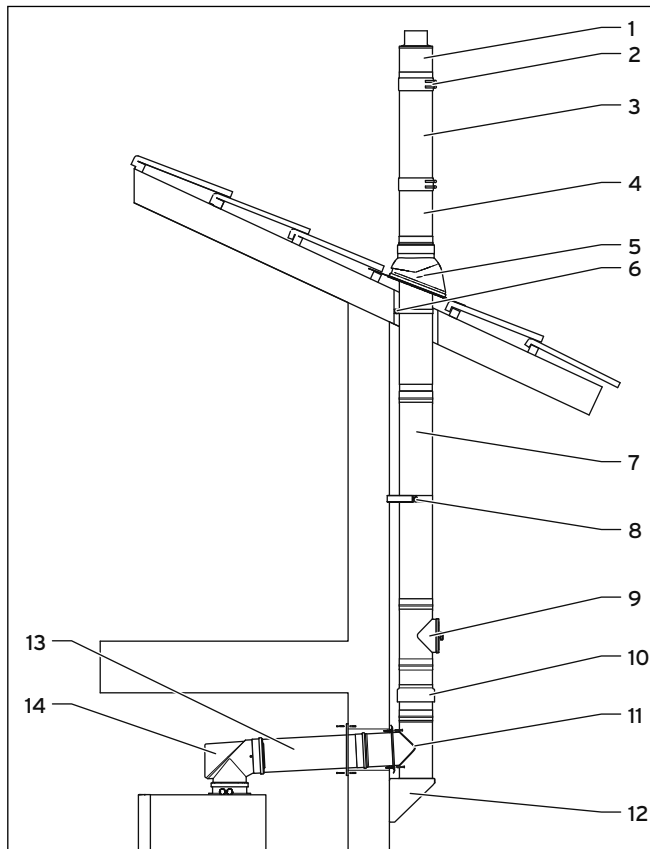

8.1 System diagram of the flue gas pipe

Key

- 1 Opening piece
- 2 Clamp
- 3 Outer extension
- 4 Roof duct
- 5 Pitched roof tile
- 6 Fastening clamp
- 7 Extension
- 8 Pipe bracket
- 9 Inspection element (Not required in all countries)
- 10 Air intake piece
- 11 Support elbow
- 12 Support console
- 13 Internal extension
- 14 Inspection elbow (Not required in all countries)

8.2 Static dimensions

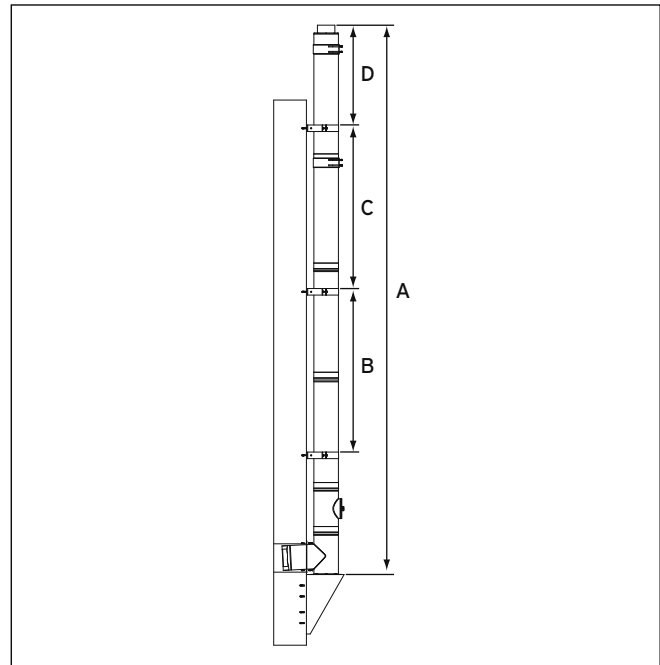

8.2 Static dimensions

Key

- A: Max. 50 m (max. vertical height above the support console)
- B: Max. 2 m (distance between the pipe brackets)
- C: Max. 2 m (distance between the two upper pipe brackets)
- D: Max. 1.5 m (max. height above the last pipe bracket)

The dimension **A** specifies the maximum height of the flue gas pipe above the support console.

If dimension **A** is exceeded, the load-bearing capacity of the console is exceeded by the vertical weight.

To ensure that any wind forces can be safely absorbed, dimension **B** must not be exceeded.

To ensure that any wind forces can be safely absorbed, dimension **C** must not be exceeded.

Dimension **D** specifies the maximum height above the highest pipe bracket that cannot be exceeded due to wind forces.



Danger!

Risk of injury due to falling parts!

Exceeding these dimensions can lead to mechanical damage to the flue gas guiding. In extreme cases, parts may become loose from the wall and fall, thus endangering persons.

- Observe the permitted height above the flue gas pipe.
- Secure at least every second extension to the external wall using a pipe bracket



Danger!

Risk of injury due to falling parts!

An offset reduces the tensile strength of the flue gas guiding and can lead to rotation or loosening of the flue gas guiding.

- Ensure that the part of the flue gas pipe that protrudes above the roof is sufficiently rigid.
- Do not install an offset between the two uppermost pipe brackets (dimension C).
- Install air clamps at all connecting joints between the two uppermost pipe brackets (dimension C) and the uppermost section (dimension D).



Danger!

Risk of injury due to falling parts!

An offset increases the risk that the flue gas guiding will become loose or twisted.

However, if an offset for the flue gas pipe is required, always observe the following precautions.

- Use 45° elbows.
- Only install one offset (→ Fig. 8.3).
- Observe the following dimensions:
 - The length of the diagonally guided section must not exceed 4 m.
 - The distance A between 2 pipe brackets (1) must not exceed 1 m.
 - The length of the vertical section must not exceed 5 m.
- Connect the 45° elbows to the extension on both sides using clamps (2).

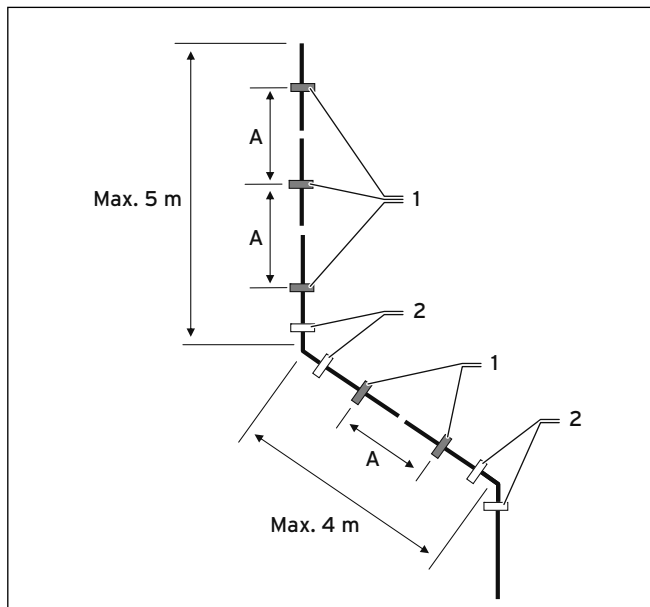

8.3 Static dimensions for an offset of the flue gas guiding

8.3 Installing the flue gas pipe

8.3.1 Installation instructions

- When installing the flue pipe, observe the following information:



Danger!

Risk of poisoning due to escaping flue gas!

Mineral-oil-based greases can damage the seals.

- Use only the supplied lubricant to facilitate installation.
- Lightly grease the seal and inserting ends.

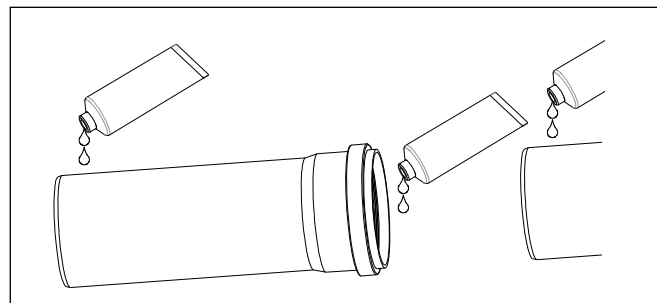

8.4 Greasing the seal and the inserting ends with lubricant

- Do not use any damaged seals.

8 Installing the flue gas pipe on the external wall

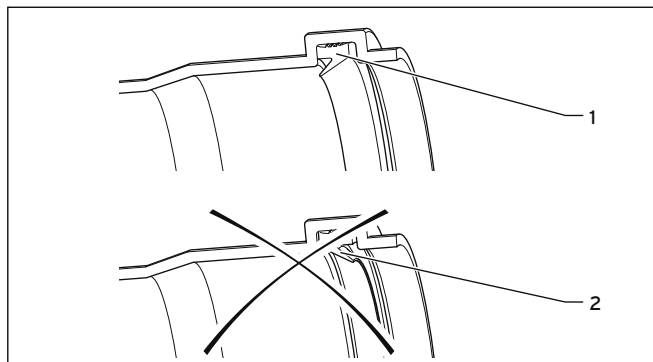

**8.5 Correct positioning of seals (1),
Incorrect positioning of seals (2)**

- When installing the pipes, always ensure that the seals are positioned correctly:
The lip of the seal must be facing inwards (1). It must not be facing outwards (2).
- Deburr the pipes.

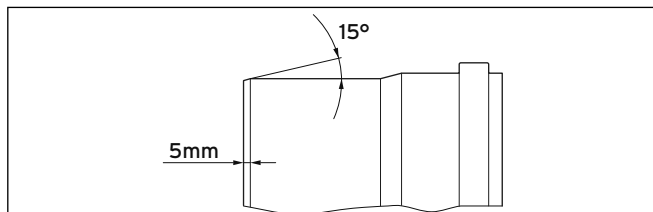

8.6 Chamfering the pipes

- Chamfer the pipes before they are installed to prevent damage to the seals. Maintain an angle of 15° and a clearance of 5 mm.
- Remove all chippings.
- Do not install any dented or otherwise damaged pipes.



Note that the pipes must be transported to the installation site only in the original packaging.

At temperatures below 0 °C, the pipes must be warmed before beginning installation.



If applicable, pay attention to any roof projection. Use the tiles for pitched roofs or the flat roof penetration collar, as required. The flue gas pipe must be positioned at a distance of 20 cm from windows and other wall openings.



Before starting installation, determine the route of the flue gas guiding and the number and position of the pipe brackets. Pay attention to the ▹ section 8.2 Static dimensions.

8.3.2 Installing the connection for the external wall pipe

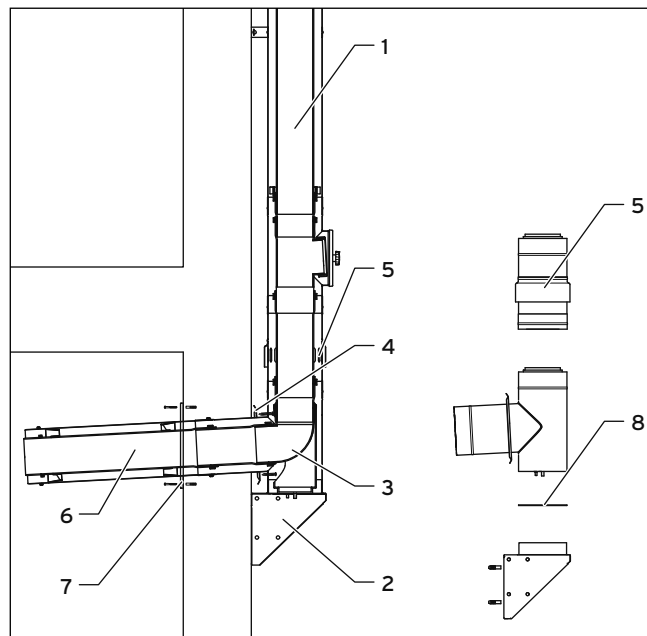

8.7 Installing the connection for the external wall pipe

Key

- 1 Outer extension
- 2 Support console
- 3 Support elbow
- 4 External collar
- 5 Air intake piece
- 6 Internal extension
- 7 Internal collar
- 8 Floor plate

- Drill a hole with a core diameter of at least 180 mm
- Fit the support console (2) to the external wall.
- Mount the support elbow (3) onto the console. In doing so, lay the base plate (8) between the support elbow and the console.



Installation errors!

The external collar (4) must be pushed onto the elbow. It is not possible to install this at a later time.

Place the external pipe of an outer extension (1) with the sleeve from inside on the support elbow.

- Install the internal extension (6) with the sleeve from inside on the support elbow.
- Fill the gap between the air pipe and the hole in the wall from inside and outside with mortar. Leave the mortar to harden.
- Install the internal collar (7).
- Install the external collar (4).
- Secure the pipe brackets at a max. distance of 2 m.

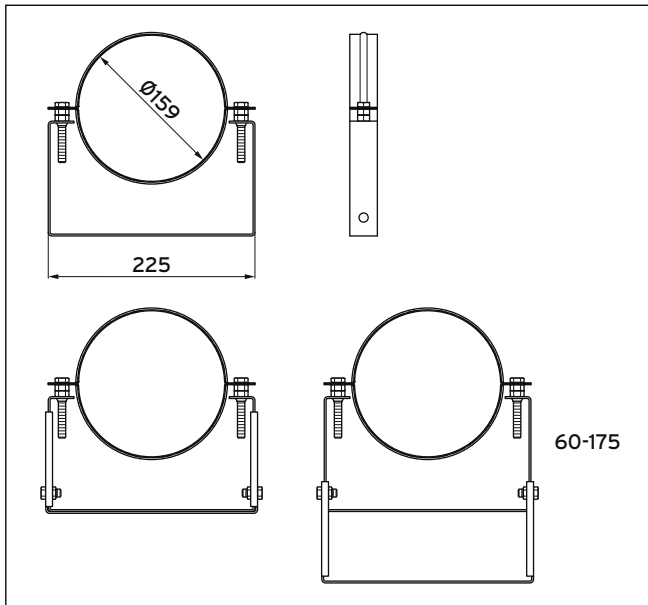

8.8 Adjustment range of the pipe brackets

The adjustment range of the pipe brackets spans from 55 mm to 95 mm. Adjust the two fastening screws within this range.

If the pipe is installed at a greater distance from the wall, extensions for the external wall brackets are required. This enables you to use a wall clearance of 175 mm.

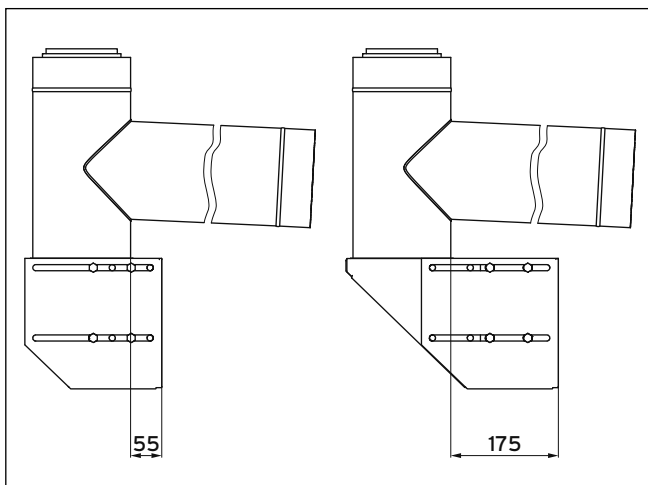

8.9 Adjustment range of the support console

The support console can also be adjusted to a distance of 175 mm using an extension.

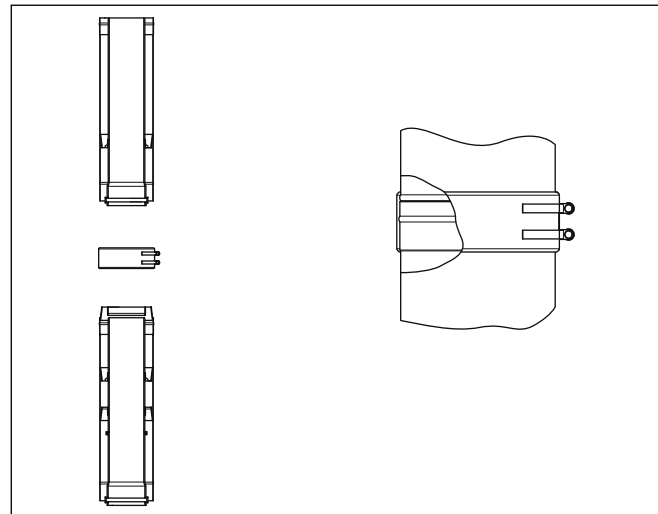

8.10 Flue gas components of the external wall system

- ▶ Install:
 - The air intake piece
 - The flue gas pipes
 - The cleaning eye, if necessary
 - The diversions
 - The terminal.



The air intake piece must not be fitted any further away from the unit than is specified in ↗ section 5.



Only the terminal is equipped with a clamp as standard. For all other connections, the clamps must be ordered as additional parts.



The terminal is made from black plastic on the flue gas side. This means that the flue opening is also resistant to UV radiation. Tighten all wall fastenings.



The opening must be at a minimum distance of 100 cm from the roof area.

- ▶ If applicable, install additional extensions and elbows starting from the wall and working towards the unit.
- ▶ Attach one fastening clamp for each extension.
- ▶ Finally, insert the elbow of the flue gas pipe into the flue gas connection of the unit.
- ▶ Connect all connecting points of the air pipes using a safety screw as described in → section 10.

8 Installing the flue gas pipe on the external wall

8.3.3 Installing the clamps

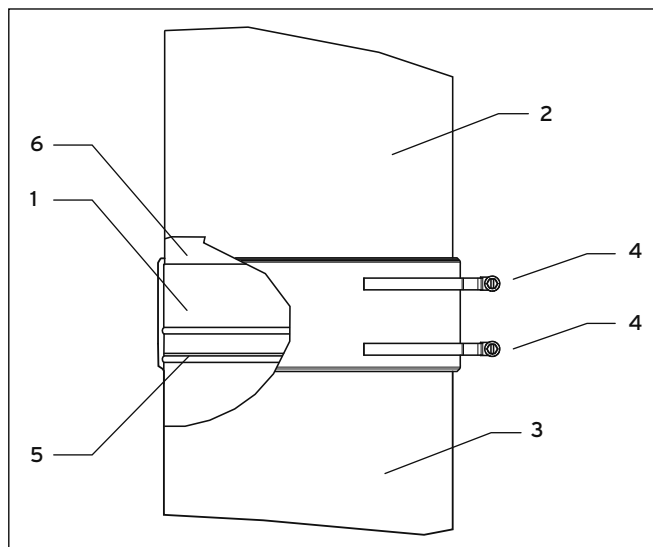

8.11 Securing the external wall elements using air clamps

Key

- 1 Clamp
- 2 External wall element
- 3 External wall element
- 4 Safety screws
- 5 Seam
- 6 Seam

- Attach one clamp (1) on each component to be connected (provided as standard on the terminal).
- Plug the component to be connected (2) and the previous component (3) together until they reach a stop.
- Place the air clamp (1) over the two external seams (5 and 6) and tighten the safety screws (4).
- Do not exceed the maximum torque of 100 Ncm.

8.3.4 Installing the roof duct

If the flue gas guiding is guided through a roof projection, the roof duct should be used to prevent rainwater from running down the external pipe.

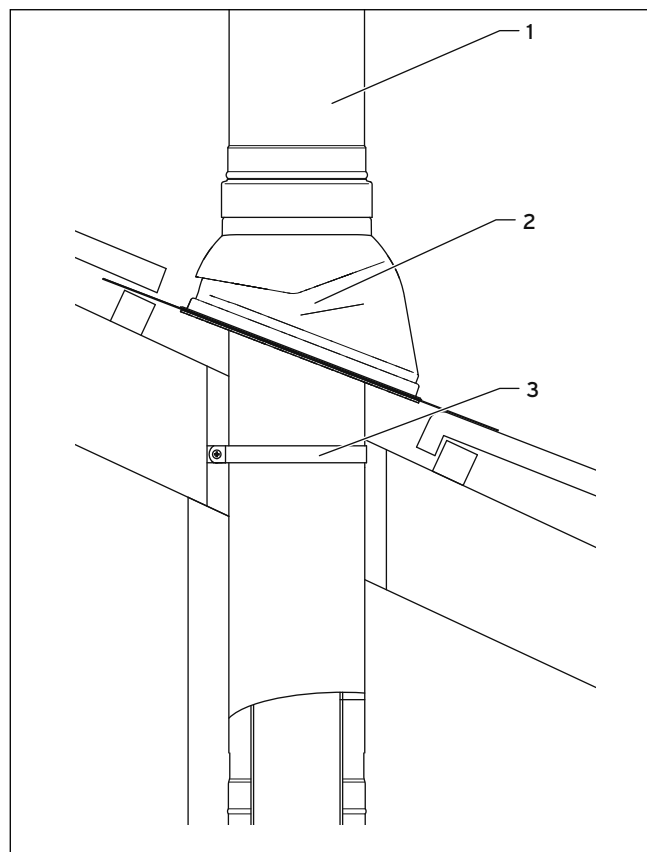

8.12 Installing the roof duct

Key

- 1 Roof duct
- 2 Pitched roof tile
- 3 Fastening clamp

- To adjust the length, place the roof duct (1) on the pitched roof tile (2) or flat roof penetration collar.
- Draw the edge to be cut on the appropriate component (extension or roof duct).



To adjust the length of the flue gas pipe between the roof duct and the lower part, you can shorten an extension, as described in → section 8.3.5, or shorten the roof duct by a maximum of 20 cm.

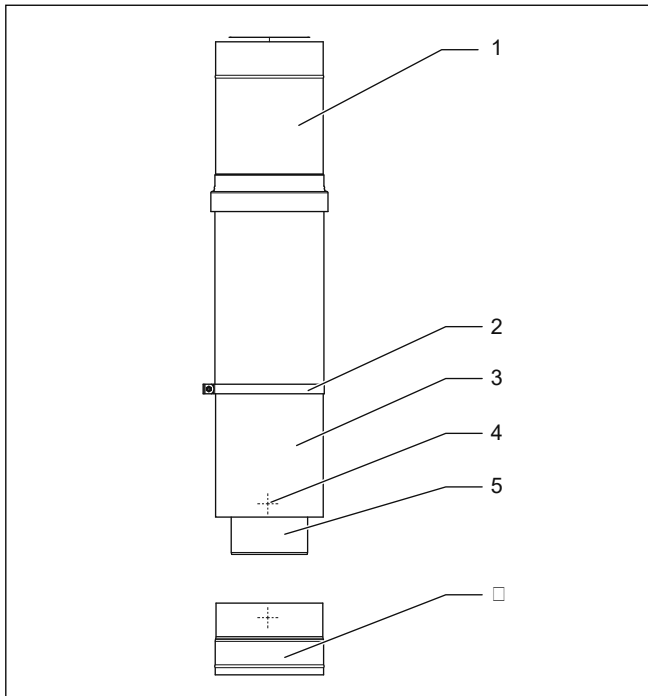

8.13 Shortening the roof duct

Key

- 1 Roof duct
- 2 Fastening clamp
- 3 External pipe of the roof duct
- 4 Internal pipe of the roof duct
- 5 Connecting sleeve

- Pull the connecting sleeve (6) out of the external pipe (3).
- Shorten the external pipe (3) and the flue pipe by an equal distance (maximum 20 cm).
- Place the connecting sleeve (6) back into the external pipe (3).
- Drill a hole (4) with a diameter of 3 mm through the external pipe and through the connecting sleeve (6).
- Install the safety screw.
- Connect all the flue components under the roof.
- Connect up all the flue components above the roof (extensions, opening piece, clamps).
- Install all the pipe brackets.
- Attach the fastening clamps of the roof duct to the rafters or ceiling.

If opening heights of more than 1.5 m are required, the roof duct must be anchored.

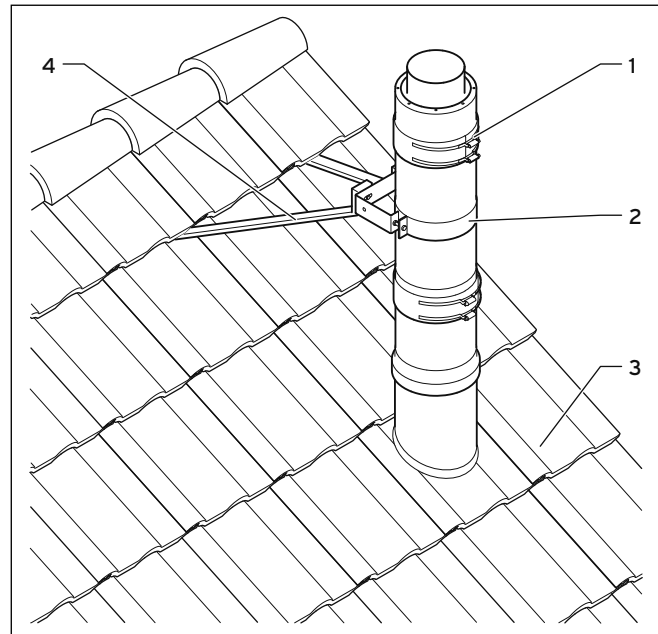

8.14 Anchoring above the roof

If the roof duct protrudes by more than 1.5 m above the tile (3), the roof duct must be secured above the roof.

- Attach clamps (1) to all the connecting points above the tile.
- Attach a pipe bracket (2) to the pipe above the roof.
- Connect this pipe bracket to the roof construction using struts (4) or rope.

8.3.5 Shortening an extension

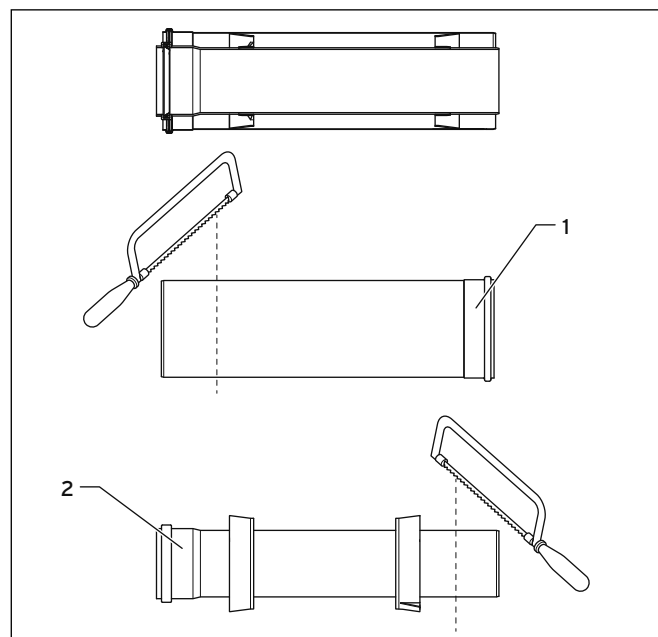

8.15 Shortening an extension

9 Installing the horizontal wall duct

- To shorten the extension, pull the flue pipe (2) out of the external pipe (1).
- Shorten the flue pipe and external pipe at right angles on their smooth side by an equal amount.



Shorten the flue pipe and external pipe at the side facing away from the sleeve.

- Slide the flue pipe (2) back into the external pipe (1).



Danger! **Risk of injury due to falling parts!**

The external pipe of the shortened extension does not have a seam on the underside. The clamp provided cannot stabilise the pipe system. Therefore, parts may fall down and cause injury to persons. To prevent this risk, follow the instructions below.

- Do not install this extension in the area in which additional clamps should be attached; or install an additional wall bracket (1) so that the system cannot become loosened and separated by wind load.
- Install an additional wall bracket directly above the shortened extension (1).

To install the horizontal flue gas pipe, follow the instructions in → **section 10**.

9 Installing the horizontal wall duct

9.1 System diagram

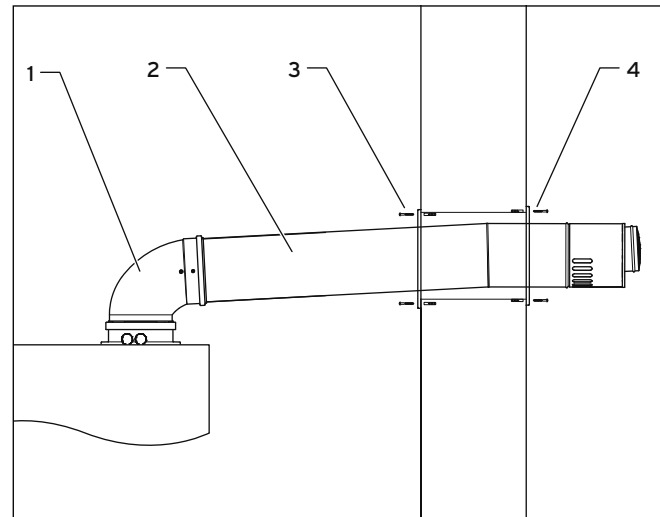

9.1 System diagram of the horizontal wall duct

Key

- 1 Elbow
- 2 Horizontal wall duct
- 3 White cover plate
- 4 Stainless steel cover plate

9.2 Installing the wall duct

- Determine the location of the wall duct in the wall.



Observe the legal regulations regarding flue gas guiding through the external wall, and the installation instructions in → section 10.

- Drill a horizontal hole with a minimum diameter of 200 mm into the wall.

Installing the horizontal flue gas pipe Ø 110/160 mm 10

9.3 Installing the horizontal wall duct

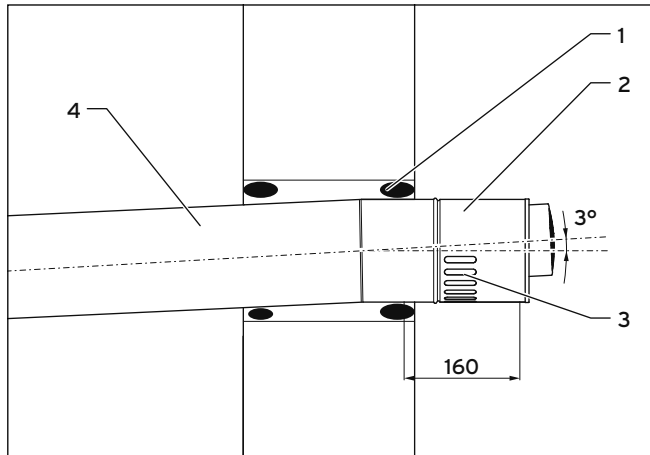

9.2 Installing the wall duct



Caution.

Risk of damage to the air pipe and unit.

The air pipe and the unit may become damaged if moisture (e.g. rainwater) enters the system.

- Always install the outer part of the wall duct (2) on a horizontal plane.
- Ensure that the air intake slots (3) are always pointing downwards.



Caution.

Malfunctions.

If you pull out the wall duct from the outside, this can lead to malfunctions of the unit.

- Seal the drilled hole from inside and outside with mortar (1).
- Leave the mortar to harden.

- Slide the wall duct (2) through the drilled hole in the wall until the wall duct projects outwards out of the wall by 160 mm.
- Install the stainless steel cover plate (3, → Fig. 9.1).
- Install the white cover plate on the inside (2, → Fig. 9.1).
- If applicable, install additional extensions and elbows starting from the wall and working towards the unit.
- Attach one fastening clamp for each extension.
- Finally, insert the elbow of the flue gas pipe into the flue gas connection of the unit.
- Connect all connecting points of the air pipes using a safety screw as described in → section 10.

10 Installing the horizontal flue gas pipe Ø 110/160 mm

Important information for the pipe guiding

- Determine the pipe guiding so that the following conditions can be complied with:

1. The horizontal flue pipe must be at a 3° downward gradient to the unit (5 cm + 1 cm tolerance per metre of pipe length).



Danger!

Risk of poisoning due to escaping flue gas!

Standing condensate can damage the seals of the flue gas pipe.

- Lay the horizontal flue pipe with a downward gradient of 3° inwards.
3° corresponds to a downward gradient of approx. 50 mm per metre of pipe length.

2. The pipes between the unit and the vertical part of the flue gas pipe must be pushed into each other until they reach a stop.
3. It must be possible to secure each pipe to the ceiling or the wall.



Danger!

Risk of poisoning due to escaping flue gas!

Extensions that are not secured to the wall or ceiling may bend and separate due to thermal expansion. Flue gases may escape.

- Secure each extension to the wall or ceiling using a pipe clamp.
- To do this, use the pipe clamps that are each secured into the wall or the ceiling using a hanger bolt or threaded bolt M8/M10. This allows for sufficient elasticity of the fastening in the event of thermal expansion of the pipes.
- The distance between two pipe clamps must not exceed the length of the extension.

10 Installing the horizontal flue gas pipe Ø 110/160 mm

4. All connecting points of the air pipes must be secured with a screw.

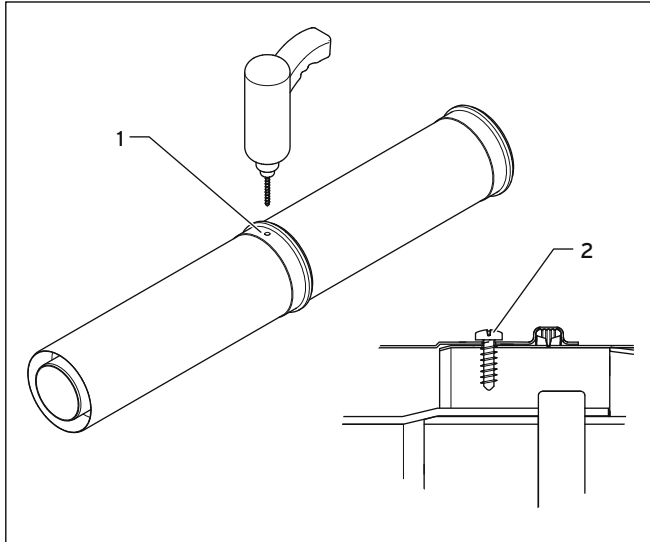

10.1 Installing the safety screw

- Drill a 3 mm hole (1) through the sleeve of the air pipe and insert the safety screw (2).



Danger!
Risk of poisoning due to escaping flue gas!

Mineral-oil-based greases can damage the seals.

- Use only the supplied lubricant to facilitate installation.
- Lightly grease the seal and inserting ends.

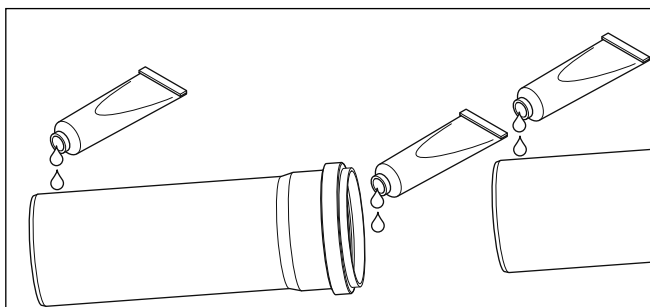

10.2 Greasing the seal and the inserting ends with lubricant

- Do not use any damaged seals.

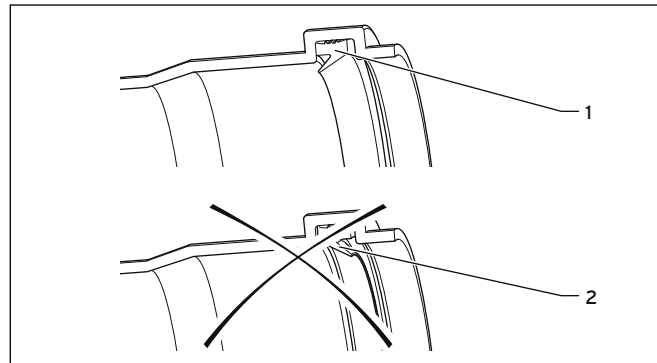

**10.3 Correct positioning of seals (1),
Incorrect positioning of seals (2)**

- When installing the pipes, always ensure that the seals are positioned correctly:
The lip of the seal must be facing inwards (1). They must not be facing outwards (2).

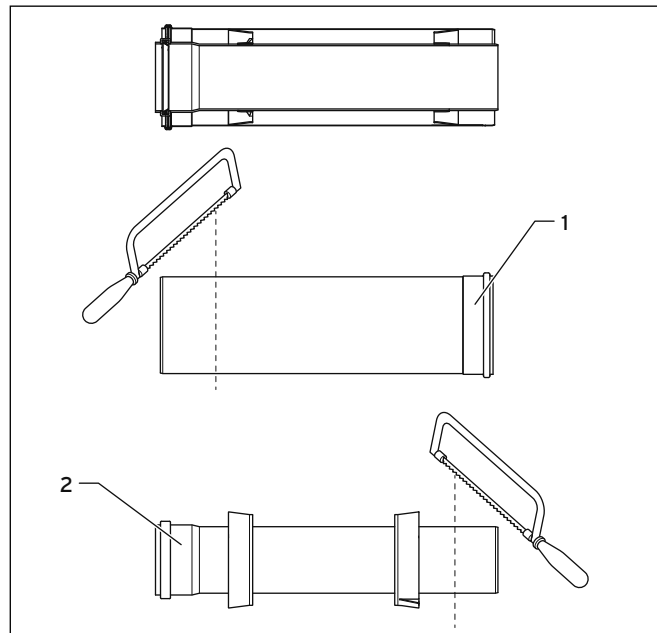

10.4 Shortening an extension

- To shorten the concentric pipe, pull the internal pipe (2) out of the external pipe (1).
- Shorten the air supply pipe and flue pipe by an equal amount.
- Deburr the pipes after shortening.

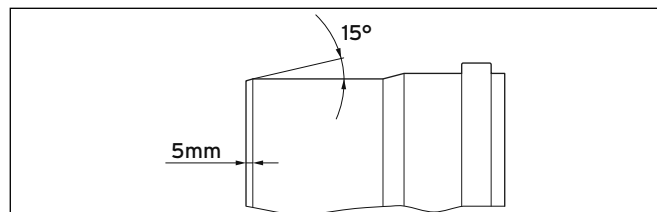

10.5 Chamfering the pipes

Installing the horizontal flue gas pipe Ø 110/160 mm 10

- Chamfer the pipes before they are installed to prevent damage to the seals. Maintain an angle of 15° and a clearance of 5 mm.
- Remove all chippings.
- Do not install any dented or otherwise damaged pipes.



Note that the pipes must be transported to the installation site only in the original packaging.

At temperatures below 0°C, the pipes must be warmed before beginning installation.



Danger!
Risk of poisoning due to escaping flue gas!

For open-flued operation, the unit must not be placed in rooms from which the air is extracted using fans (for example, ventilation systems, extractor hoods, tumble dryer ventilation). These systems generate negative pressure in the room. This negative pressure can cause flue gas to be sucked into the installation room from the opening through the annular clearance between the flue gas pipe and the shaft.

- The unit can only be used in open-flued operation if simultaneous operation of the unit and the fan is not possible.



Caution.
Unit may malfunction!

In open-flued operation, a sufficient supply of fresh air must be ensured.

- Keep all air inlet openings free of obstruction!
Otherwise, it cannot be guaranteed that the unit will function without fault.
- The combustion air supply (inlet air) for the condensing boiler must enter through an opening that leads to external air.
- For total nominal heat outputs of up to 50 kW, the cross-section of this opening must be at least 150 cm². For all total nominal heat outputs exceeding 50 kW, 2 cm² must be added to the 150 cm² for each additional kilowatt. Combustion air pipes that lead to external fresh air must have equivalent dimensions with regard to the flow properties. The required cross-section must be spread between a maximum of two openings.



Caution.
Risk of damage to the structure of the building!

In open-flued operation, minor, permitted leakages of flue gas may cause moisture to enter the shaft. The shaft must therefore be ventilated in order to divert the flue gas leakages outside.

- Install an air inlet opening at the lower end of the shaft with a diameter of at least 140 cm².
- Enclose the opening using the intake grille, article number 0020117198 (spare part).

Index

Index

C

Chamfering the pipes..... 22
Competent persons..... 4

E

Elbow 9, 11

F

Fire protection 5
Flue gas exit..... 4
Flue gas guiding..... 5, 21, 22
Flue gas pipe 4, 20, 22, 24

I

Installation options 7
Installation site of the roof duct 17
Intended use 5

L

Lubricant 21

M

Maximum pipe lengths..... 15

O

Offset of the flue gas guiding 21
Opening 16
Opening piece..... 25

P

Performance features for flue pipe..... 16
Pipe bracket
 Adjustment range 23
Pipe element 11, 12, 13, 14

R

Regulations 5
Risk of corrosion..... 4

Risk of suffocation 4
Roof 21, 22, 25

S

Safety 4
Seal 5, 21, 27, 28
Shortening an extension 25
Signal word 4
Static dimensions..... 20
Support console
 Adjustment range 23

T

Temperature 22, 29
Tool 4



0020137851_04

Supplier

Vaillant Ltd

Nottingham Road ■ Belper ■ Derbyshire ■ DE56 1JT

Telephone 0330 100 3461 ■ www.vaillant.co.uk ■ info@vaillant.co.uk

Manufacturer

Vaillant GmbH

Berghauser Str. 40 ■ D-42859 Remscheid ■ Telefon 0 21 91/18-0

Telefax 0 21 91/18-28 10 ■ www.vaillant.de ■ info@vaillant.de