

**PLEASE NOTE**  
THE STEP BY STEP GUIDE IS NOT INTENDED TO REPLACE THE INSTALLATION LITERATURE. IT SHOULD BE USED ONLY AS A REFERENCE.

- Note: Before securing the wall hanging bracket the following considerations must be made:
1. Rear or Turret flue (see Step 2)
  2. Position of boiler
  3. Hole for flue.

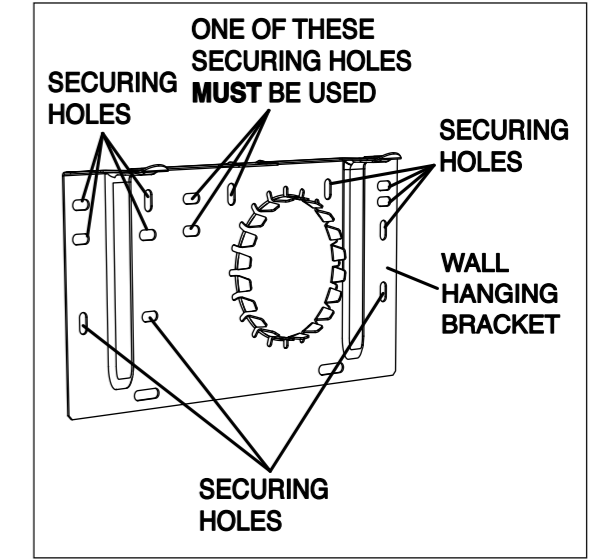

**Step 1**

Note: If external access is not available for rear flue installation, then it must be assembled and inserted into the hole before securing the wall hanging bracket.

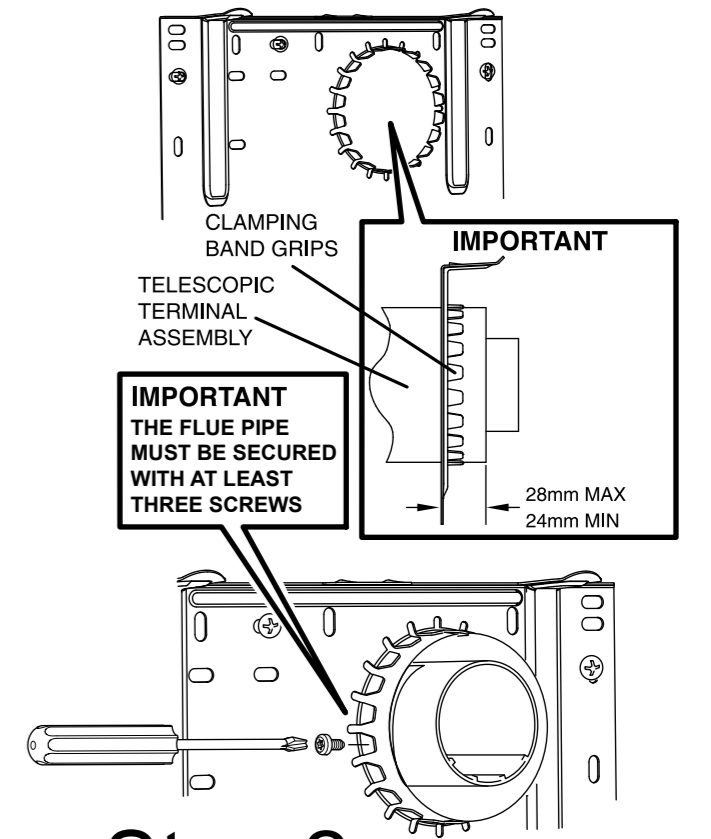

**Step 2**

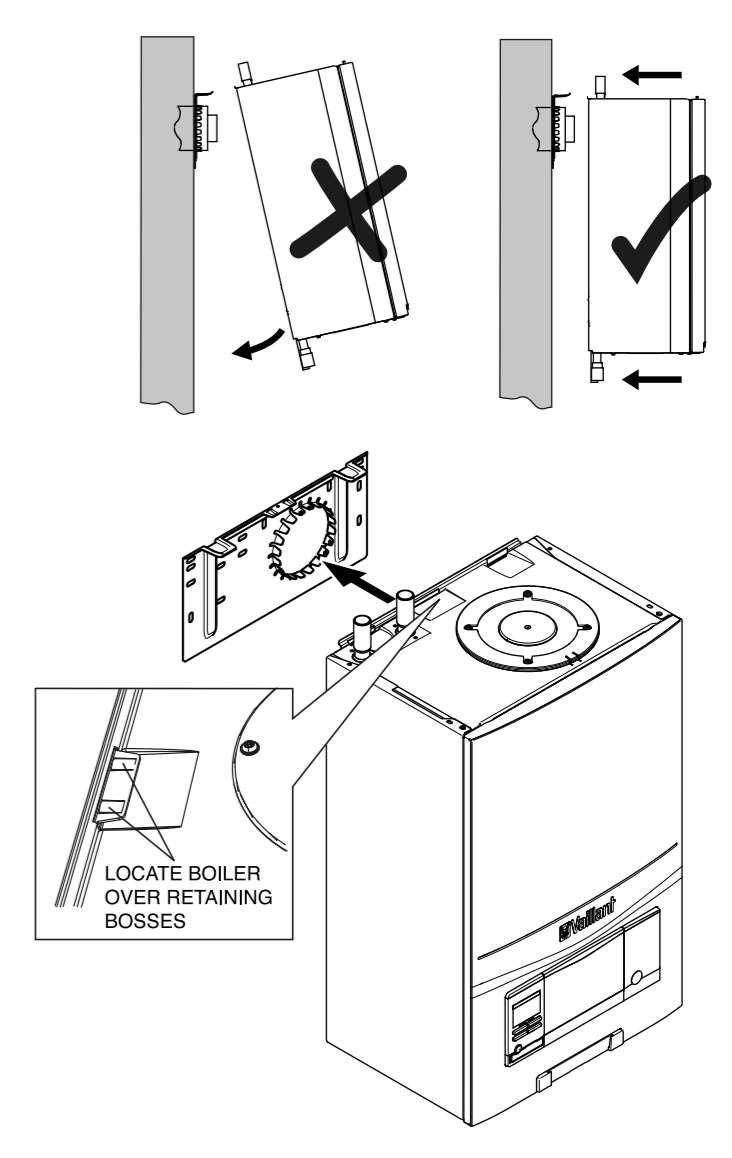

**Step 3**

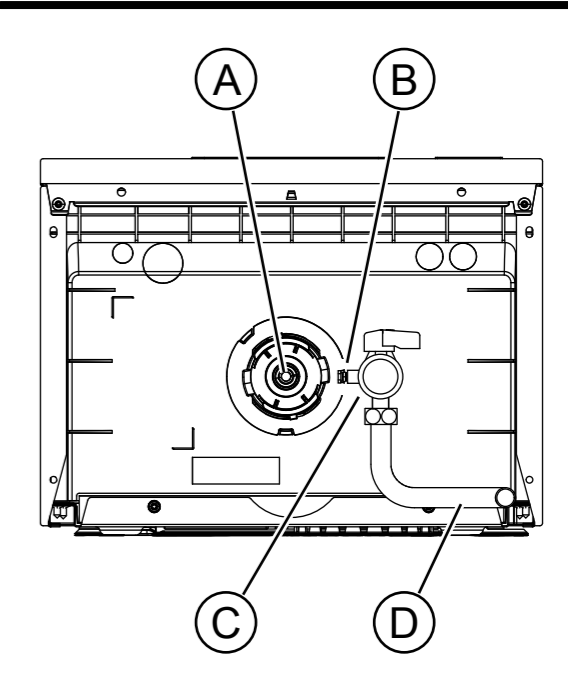

- A - Condensate Connection
- B - Pressure Test Point
- C - Gas Service Cock
- D - Gas Supply Pipe In

**Step 4**

WALL TEMPLATE



0020231640\_00



Ø110 EXTERNAL ACCESS  
Ø125 INTERNAL ACCESS

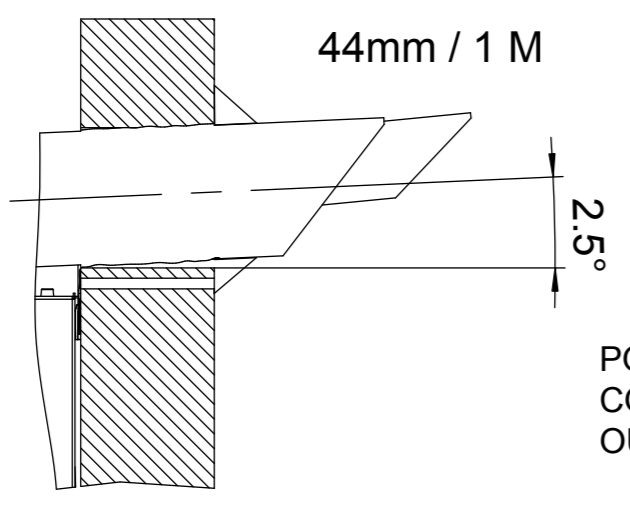
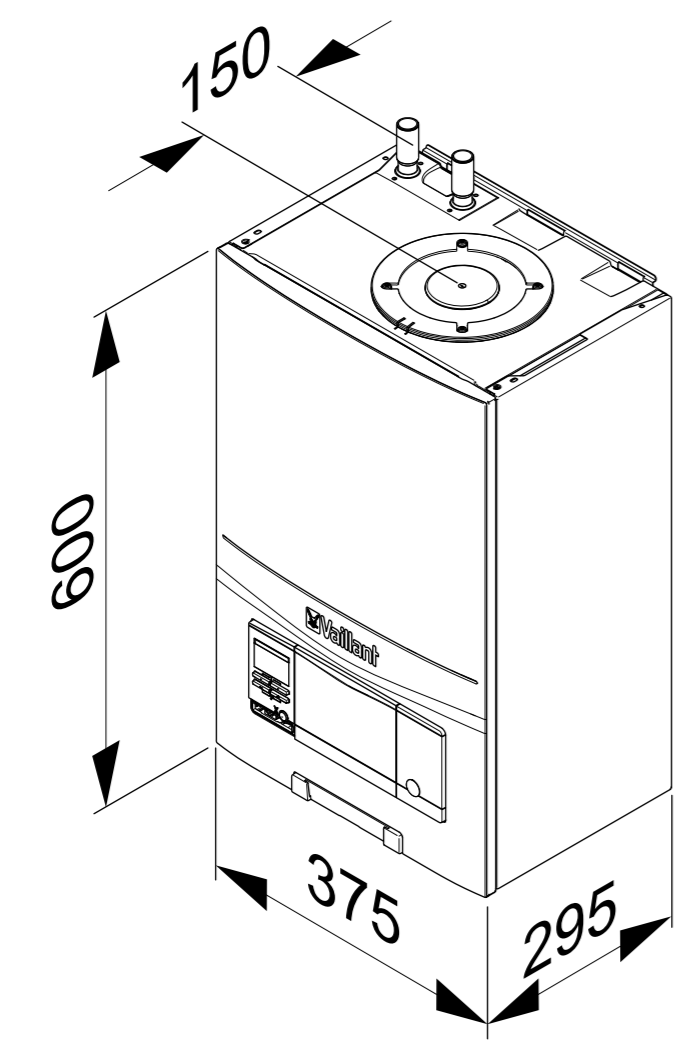
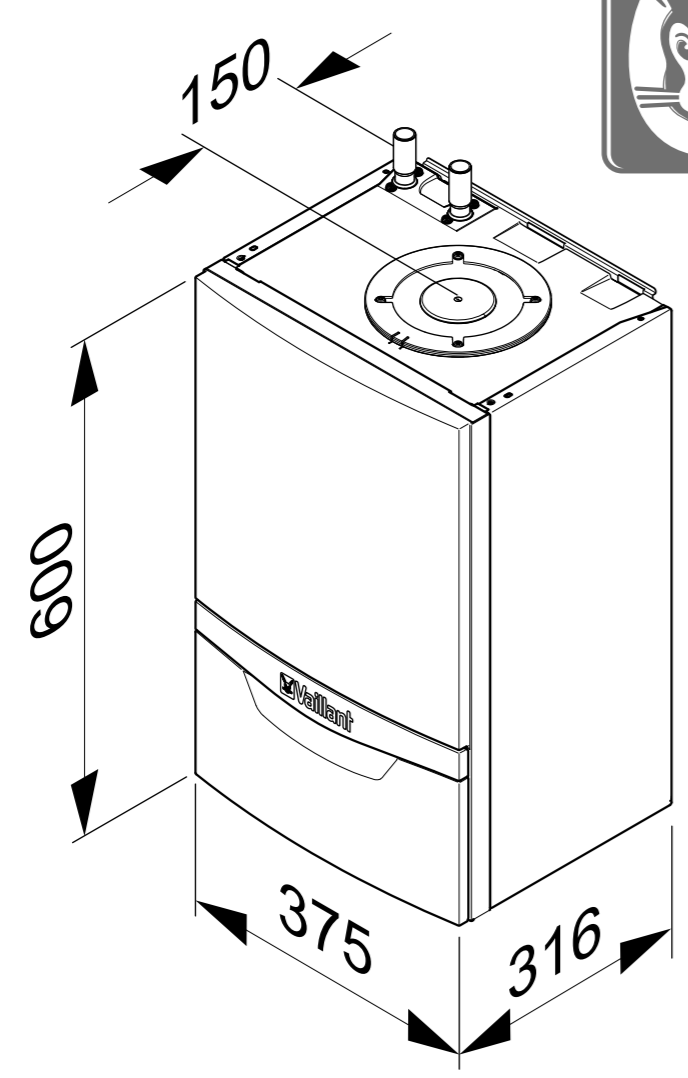

**BOILER**

⊘

☆

□

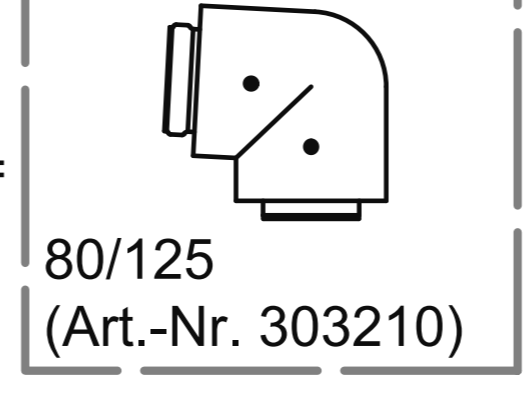
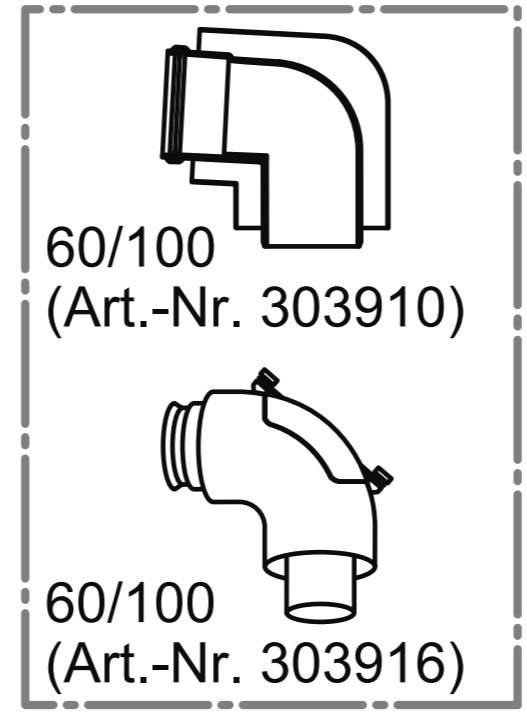
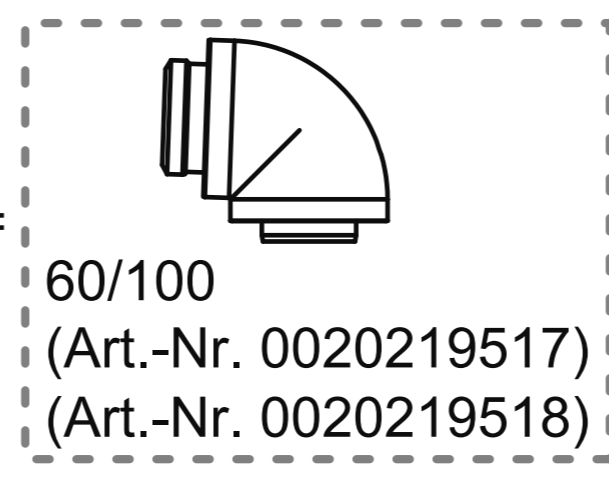

OUTLINE OF BOILER

5 mm Min. Clearance

POSITION CONDENSATE OUTLET

5 mm Min. Clearance

150

MINIMUM CLEARANCE

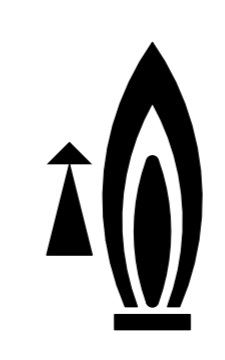

0020231640\_00 - 05/16